



OPERATION AND MAINTENANCE

COMPOSITE SLIDER WRECKERS

Model(s): 30CS-40CS-50CS

Tuesday, August 19, 2025

Document number: 8923102 — Revision 2

Original Instructions



NRC-INDUSTRIES.COM

Serial number:



INTELLECTUAL PROPERTY NOTICE

Copyright © 2025 NRC Industries Inc. All rights reserved. This manual may not be copied, photocopied, reproduced, translated or converted to any electronic or machine-readable format in whole or in part without the prior written approval of NRC Industries Inc. NRC Industries Inc. reserves the right to modify the information provided herein at any time without notice.

Please send your comments and questions to:

NRC Industries Inc.
2430 Principale St.
Saint-Paul-d'Abbotsford, QC J0E 1A0
CANADA
Tel: (450) 379-5796
Fax: (450) 379-5995

For any questions about the winches, you can contact the manufacturers directly:

DP Winch (TWG, Inc.)
PO Box 1130
Jenks, OK 74037-1130
Tel: (918) 298-8300
Fax: (918) 298-8301
Website: www.dovertwg.com

Ramsey Winch Company
PO Box 581510
Tulsa, OK 74158-1510
Tel: (918) 438-2760
Fax: (918) 438-6688
Website: www.ramsey.com

REVISION HISTORY

Revision	Date	Description
2	2025-08-19	Correction to section 3.5.
1	2022-05-23	Major revisions for new models of CS wreckers, including but not limited to adding sections 2.7 and 3.5, as well as editing sections 3.8, 4.3, 4.4 and 5.1. Formatting changes.
0	2022-07-15	Initial release

CONTENTS

LIMITED WARRANTY	9
WARRANTY CARD	11
LEGAL STANDARDS AND REQUIREMENTS	13
ABOUT THIS MANUAL	15
WARNING MESSAGES	17
1 DESCRIPTION	19
1.1 Description of the wrecker and its components	19
1.2 Technical specifications	39
2 SAFETY	55
2.1 General	55
2.2 Safety labels	55
2.3 Intended use	55
2.4 NRC responsibilities	56
2.5 Supervisory responsibilities	56
2.6 Operator responsibilities	57
2.7 Conditions for use	59
3 OPERATION	61
3.1 Operating principles	61
3.2 Preparing the wrecker for optimal performance	66
3.3 Safety guidelines	67
3.4 Familiarizing yourself with the equipment	67
3.5 Emergency hydraulic bypass	68
3.6 Common operating procedures	70
3.7 Using the jack legs	72
3.8 Using the underlift	74
3.9 Using the boom	90
3.10 Using the winch	92
3.11 Using the remote control with control levers	95
3.12 Using the remote control that has 6, 10 or 16 function buttons	97
4 MAINTENANCE	99
4.1 Safety guidelines	99
4.2 General maintenance	100
4.3 Lubrication	108

4.4 Maintenance procedures 118

5 TROUBLESHOOTING 125

 5.1 Troubleshooting common problems 126

 5.2 Checking the boom cylinder 132

 5.3 Checking the PTO 134

6 ACCIDENT OR BREAKDOWN PROCEDURE 135

 6.1 Electrical failure 135

 6.2 Hydraulic failure 136

 6.3 Pump failure 136

 6.4 Truck failure 136

 6.5 Underlift stinger failure 136

7 STORAGE 137

8 DISASSEMBLY AND DISPOSAL 139

AUTHORIZED DISTRIBUTORS AND SERVICE PROVIDERS 141

LOGBOOK 143

OPERATOR RECORD 145

LIMITED WARRANTY

A. GENERAL PROVISIONS - THE WARRANTY DESCRIBED BELOW IS PROVIDED BY INDUSTRIES NRC INC, 2430 PRINCIPALE EST C.P. 160, ST-PAUL D'ABBOTSFORD, QUÉBEC, CANADA, J0E 1A0 ("INDUSTRIES NRC") TO THE ORIGINAL PURCHASER OF NEW TOWING AND RECOVERY EQUIPMENT ("EQUIPMENT") PURCHASED FROM INDUSTRIES NRC OR AUTHORIZED INDUSTRIES NRC DEALERS. UNDER THIS WARRANTY, INDUSTRIES NRC WILL REPAIR OR REPLACE, AT ITS OPTION, ANY PART COVERED UNDER THIS WARRANTY WHICH IS FOUND TO BE DEFECTIVE IN MATERIAL OR WORKMANSHIP DURING THE APPLICABLE WARRANTY TERM. WARRANTY SERVICE MUST BE PERFORMED BY A DEALER OR SALES SERVICE CENTRE AUTHORIZED BY INDUSTRIES NRC TO SELL AND/OR SERVICE THE EQUIPMENT (THE "AUTHORIZED DEALER"). THE AUTHORIZED DEALER WILL USE ONLY NEW OR REMANUFACTURED PARTS OR COMPONENTS FURNISHED OR APPROVED BY INDUSTRIES NRC. WARRANTY SERVICE WILL BE PERFORMED WITHOUT CHARGE TO THE PURCHASER FOR PARTS. HOWEVER, THIS WARRANTY DOES NOT OBLIGATE INDUSTRIES NRC TO BEAR THE COST OF LABOR OR TRANSPORTATION CHARGES IN CONNECTION WITH THE REPAIR OR REPLACEMENT OF ANY PARTS FOUND TO BE DEFECTIVE, NOR SHALL IT APPLY TO A PRODUCT UPON WHICH REPAIRS OR ALTERATIONS HAVE BEEN MADE UNLESS AUTHORIZED BY INDUSTRIES NRC. THE PURCHASER WILL BE RESPONSIBLE FOR SERVICE CALLS AND/OR TRANSPORTATION OF EQUIPMENT TO AND FROM THE AUTHORIZED DEALER'S PLACE OF BUSINESS (EXCEPT WHERE PROHIBITED BY LAW), FOR ANY PREMIUM CHARGED FOR OVERTIME LABOUR REQUESTED BY THE PURCHASER AND FOR ANY SERVICE AND/OR MAINTENANCE NOT DIRECTLY RELATED TO ANY DEFECT COVERED UNDER THIS WARRANTY. THIS WARRANTY IS TRANSFERABLE, PROVIDED AN AUTHORIZED INDUSTRIES NRC DEALER IS NOTIFIED OF THE OWNERSHIP CHANGE, AND INDUSTRIES NRC APPROVES THE TRANSFER.

B. WHAT IS WARRANTED - SUBJECT TO PARAGRAPH C, ALL PARTS, MANUFACTURED BY INDUSTRIES NRC, OF ANY NEW INDUSTRIES NRC EQUIPMENT, ARE WARRANTED FOR THE NUMBER OF MONTHS SPECIFIED BELOW. WARRANTY STATEMENTS COVERING COMPONENTS NOT MANUFACTURED BY NRC ARE FOUND WITH THE OPERATOR'S MANUALS DELIVERED WITH THE EQUIPMENT.

C. WHAT IS NOT WARRANTED - PURSUANT TO THE TERMS OF THIS WARRANTY, INDUSTRIES NRC IS NOT RESPONSIBLE FOR THE FOLLOWING: (1) USED EQUIPMENT (UNLESS IT IS SPECIFICALLY COVERED BY SEPARATE WARRANTY DOCUMENTS); (2) ANY EQUIPMENT THAT HAS BEEN ALTERED OR MODIFIED IN WAYS NOT APPROVED BY INDUSTRIES NRC, INCLUDING, BUT NOT LIMITED TO, HYDRAULIC PRESSURE SETTINGS ABOVE INDUSTRIES NRC SPECIFICATIONS; (3) DEPRECIATION OR DAMAGE CAUSED BY NORMAL WEAR, LACK OF REASONABLE AND PROPER MAINTENANCE, FAILURE TO FOLLOW OPERATING INSTRUCTIONS, MISUSE, LACK OF PROPER PROTECTION DURING STORAGE, VANDALISM, THE ELEMENTS OR COLLISION OR ACCIDENT; (4) THE EQUIPMENT IF USED FOR OVERHEAD LIFTING, CRANE WORK OR ANY OTHER UNAPPROVED ACTIVITY; (5) NORMAL MAINTENANCE PARTS AND/OR SERVICE.

D. SECURING WARRANTY SERVICE - TO SECURE WARRANTY SERVICE THE PURCHASER MUST, (1) REPORT THE EQUIPMENT DEFECT TO AN AUTHORIZED DEALER AND REQUEST WARRANTY SERVICE WITHIN THE APPLICABLE WARRANTY TERM; (2) PRESENT EVIDENCE OF THE WARRANTY START DATE TOGETHER WITH THE VALID PROOF OF PURCHASE; AND, (3) MAKE THE EQUIPMENT AVAILABLE TO AN AUTHORIZED DEALER OR SERVICE CENTRE WITHIN A REASONABLE PERIOD OF TIME.

E. NO IMPLIED WARRANTY, REPRESENTATION OR CONDITION - TO THE EXTENT PERMITTED BY LAW, NEITHER INDUSTRIES NRC NOR ANY COMPANY AFFILIATED WITH IT MAKES ANY WARRANTY, REPRESENTATION, CONDITION OR PROMISE, EXPRESS OR IMPLIED, VERBAL OR OTHERWISE, AS TO THE QUALITY, PERFORMANCE OR FREEDOM FROM DEFECT OF THE EQUIPMENT. NO IMPLIED OR STATUTORY CONDITIONS OR WARRANTIES OF MERCHANTABILITY OR FITNESS (WHETHER PURSUANT TO THE SALE OF GOODS ACT OR ANY OTHER STATUTE OF ANY PROVINCE/STATE OR OTHERWISE) ARE MADE.

F. EXCLUSIVE REMEDY - TO THE EXTENT PERMITTED BY LAW, THE PURCHASER'S EXCLUSIVE REMEDY IN CONNECTION WITH THE BREACH OR PERFORMANCE OF ANY WARRANTY ON THE EQUIPMENT ARE THOSE SET FORTH IN THIS WARRANTY. IN NO EVENT WILL AN AUTHORIZED DEALER, INDUSTRIES NRC OR ANY COMPANY AFFILIATED WITH INDUSTRIES NRC, BE LIABLE FOR ANY INCIDENTAL OR CONSEQUENTIAL DAMAGES OR INJURIES, INCLUDING BUT NOT LIMITED TO, LOSS OF PROFITS, RENTAL OF SUBSTITUTE EQUIPMENT, OTHER COMMERCIAL OR PERSONAL LOSS OR DAMAGES ARISING AS A RESULT OF A FUNDAMENTAL BREACH OR BREACH OF A FUNDAMENTAL TERM.

G. NO DEALER WARRANTY - EXCEPT FOR CONDITIONS OR WARRANTIES WHICH MAY NOT BE EXCLUDED BY LAW, THE SELLING DEALER MAKES NO WARRANTY OF ITS OWN ON ANY ITEM WARRANTED BY INDUSTRIES NRC, AND MAKES NO WARRANTY ON OTHER ITEMS UNLESS IT DELIVERS TO THE PURCHASER A SEPARATE WRITTEN WARRANTY DOCUMENT SPECIFICALLY WARRANTING THE ITEM. THE SELLING DEALER HAS NO AUTHORITY TO MAKE ANY REPRESENTATION OR PROMISE ON BEHALF OF INDUSTRIES NRC OR TO MODIFY THE TERMS OR LIMITATIONS OF THIS WARRANTY IN ANY WAY.

H. WARRANTY TERMS

EQUIPMENT

TERMS

TRUCK MOUNTED RECOVERY EQUIPMENT

12 MONTHS FROM "IN SERVICE" DATE. NO MORE THAN 24 MONTHS.

SLIDING SYSTEM COMPONENTS

10 YEARS FROM DATE OF MANUFACTURING.

TOWING ACCESSORIES MANUFACTURED BY INDUSTRIES NRC

12 MONTHS FROM DATE OF MANUFACTURING.

ACCESSORIES MANUFACTURED BY A THIRD PARTY

THIRD PARTY WARRANTY APPLIES.

WARRANTY REGISTRATION FORM



On the date of sale I have read the NRC Warranty Agreement, I understand its terms & conditions, and acknowledge receipt of my copy of the agreement.
PLEASE PRINT CLEARLY OR TYPE.

INFORMATION ON THE CHASSIS ON WHICH THE NRC UNIT IS INSTALLED															
IMPERIAL (lbs,mi) <input type="checkbox"/>	METRIC (kg,km) <input type="checkbox"/>	Used <input type="checkbox"/>	New <input type="checkbox"/>												
GVWR :	FRONT	REAR													
MAKE :	MODEL	YEAR													
VEHICLE IDENTIFICATION NUMBER (CHASSIS)												MILEAGE			

NRC UNIT
Date of Sale : _____

First Puschaser's Name

NRC Serial # _____
Axle-lift
Serial # _____

Address : _____

NRC Model # _____

Postal / Zip code : _____

Date of Delivery to Dealer :

Purchaser's Company Title / Position

Dealer Name :

Purchaser's Signature :

Address : _____

X _____

Postal / Zip code : _____

Date : _____

Dealer Signature :

Primary Contact-Necessary for Warranty-Admin

Date : _____

Name : _____

Phone : _____

The following items are to be performed by dealer at the time of vehicle delivery. Customer to sign off each item as verification that it was performed.			
	Completed the NRC Warranty Registration Form		Explain required maintenance program to Customer
	Customer instructed on the safe and proper operation of the unit purchased.		
	Explain and demonstrate vehicle and Accessory operation to Customer.		Present completed Warranty registration. Copy to Customer & fax copy to NRC Warranty Department.
	PRE-DELIVERY INSPECTION		Customer Signature

This Warranty is not valid until approved by NRC Industries and all items on this form completed.

LEGAL STANDARDS AND REQUIREMENTS

The NRC sliding wreckers featured in this manual meet the following legal standards and requirements:

CE

	CE	Rest of world
2006/42/CE	X	
2014/30/UE	X	
2014/53/UE	X	
768/2008/CE	X	

Harmonized standards

	CE	Rest of world
EN 82079-1	X	
EN ISO 12100	X	
EN 14492-1 (for the winches)	X	

Other standards

	CE	Rest of world
SAE J2512		X
SAE J706 (for the winches)		X
FMVSS/CMVSS 108 (Canada and USA)		X

ABOUT THIS MANUAL

This manual contains important information about how to safely operate and maintain your NRC composite slider wrecker. Read it before operating the machine and retain it for future reference during the entire lifespan of the machine.

This manual contains the following chapters:

- Chapter 1 presents the wrecker models, their components and their technical specifications.
- Chapter 2 provides safety information for operating, maintaining and troubleshooting the wrecker.
- Chapter 3 provides operating principles and procedures.
- Chapter 4 provides maintenance information and procedures.
- Chapter 5 provides troubleshooting information and procedures.
- Chapter 6 provides the operating method in case of an accident or equipment breakdown.
- Chapter 7 provides information about taking the wrecker in and out of storage.
- Chapter 8 provides information for disassembling and disposing of the wrecker.

Document conventions

The following conventions are used throughout this document:

NOTE: We highly recommend that you read this manual in full before using your NRC equipment.

Disclaimer

This manual, including the equipment specifications, is subject to change without notice. Ensure that you have the latest version of this manual before using your equipment.

All ratings are based on structural factors only, not vehicle capacities or capabilities.

Applicable models and serial numbers

This manual is intended for use with the following models with serial numbers within the following ranges only:

- 30CS-047 to ...
- 40CS-185 to ...
- 50CS-063 to ...

WARNING MESSAGES

DANGER

DANGER - Immediate hazards or unsafe practices that will result in severe personal injury or death.

WARNING

WARNING - Hazards or unsafe practices that could result in severe personal injury or death.

CAUTION

CAUTION - Hazards or unsafe practices that could result in minor personal injury or equipment damage.

NOTICE

Indicates information that should be read to avoid equipment damage.

1 DESCRIPTION

The NRC composite slider is a dream machine, a tough and versatile unit for recovery work and extra-heavy towing. Specially designed for the most difficult tasks, the CS with its sliding system brings you the best "USABLE BOOM CAPACITY".

This chapter describes the components of wrecker models 30CS, 40CS, and 50CS and lists their technical specifications.

1.1 Description of the wrecker and its components

NRC CS wreckers are manufactured with the same main components and share the same operation principles. Only their sizes and capacities are different. See Section 1.2 Technical specifications for the CS wrecker model specifications.

All the CS models can be equipped with a two-stage boom and the 40CS and 50CS can be equipped with a three-stage boom.

Seven underlift models are available and can be installed on any sliding rotator system model:

- **HD-3:** Heavy Duty – three-stage
- **HDE-3:** Heavy Duty Euro – three-stage
- **SHD-3:** Super Heavy Duty – three-stage
- **LSHDE-3:** Long Super Heavy Duty Euro – three-stage
- **XSHDE-3:** Extra Long Super Heavy Duty Euro – three-stage
- **SSHD-4:** Short Super Heavy Duty – four-stage
- **LSHD-4:** Long Super Heavy Duty – four-stage

The following sections outline the chassis, boom and underlift characteristics.

1.1.1 Chassis

The chassis supports all the wrecker components. Figure 1 and Figure 2 show the wrecker with and without its underlift.

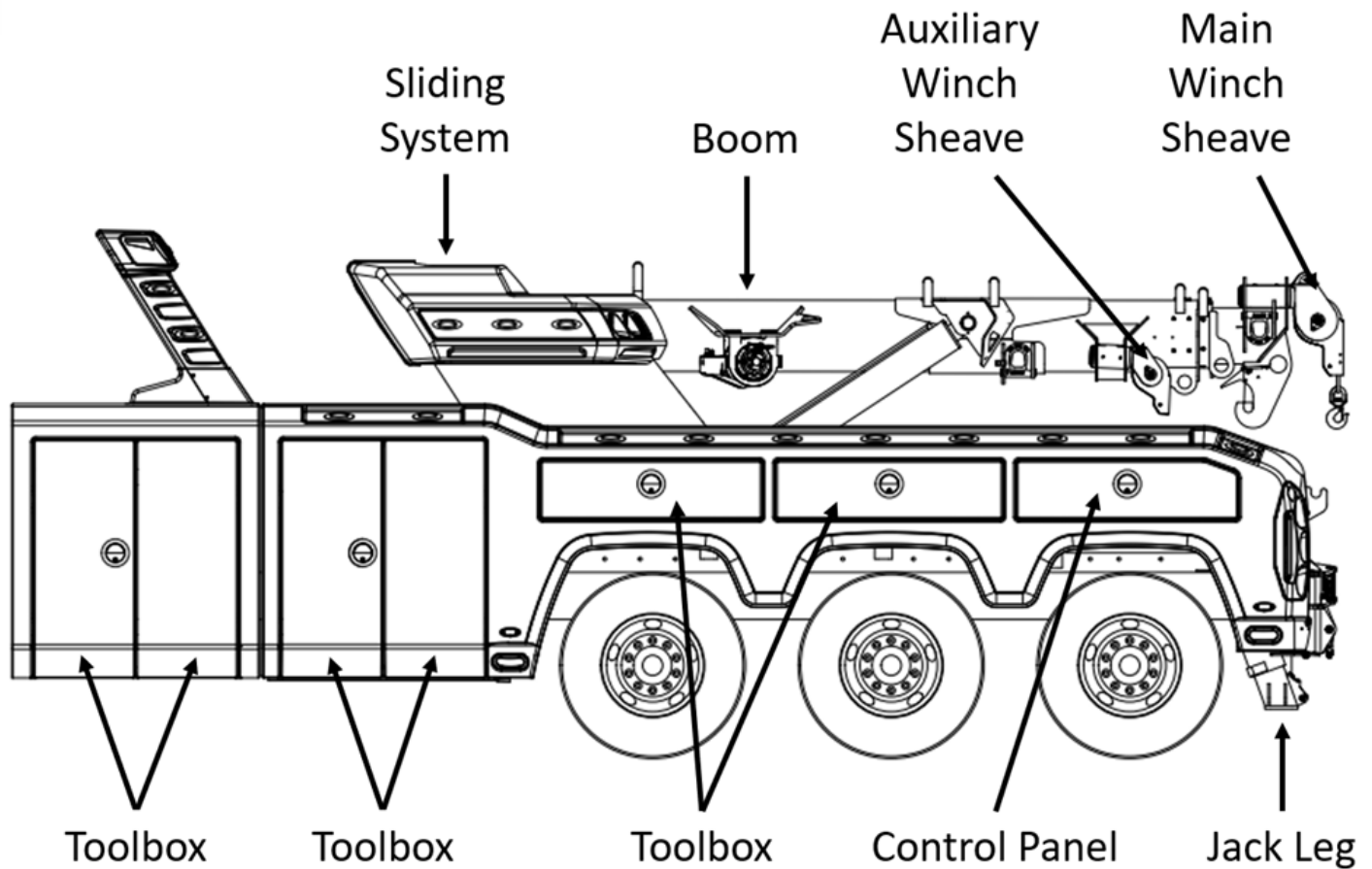

FIGURE 1 – CHASSIS WITHOUT UNDERLIFT (EXAMPLE)

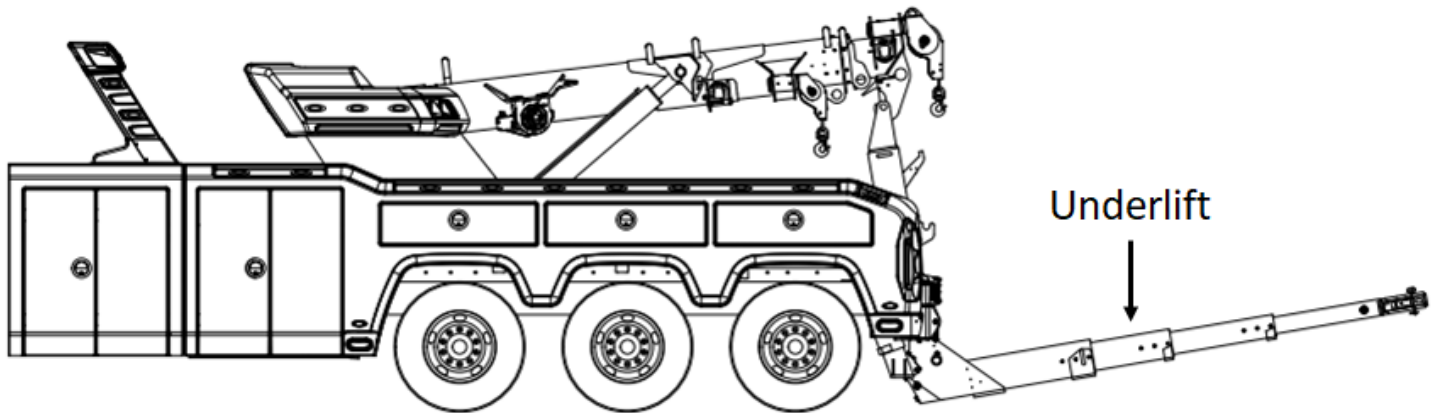

FIGURE 2 – CHASSIS WITH UNDERLIFT (EXAMPLE)

1.1.2 Jack legs

The wrecker has two jack legs: back-left and back-right. The jack legs are used to stabilize the wrecker on the ground. Figure 1 shows the jack legs.

1.1.3 Jack legs with extendable stabilizers

The wrecker may also have an extendable stabilizer on each jack leg. The stabilizers have horizontal extensions to provide even more stability.

1.1.4 Boom

The mast has two or three boom sections, depending on which option you selected. Figure 3 shows a boom and its components.

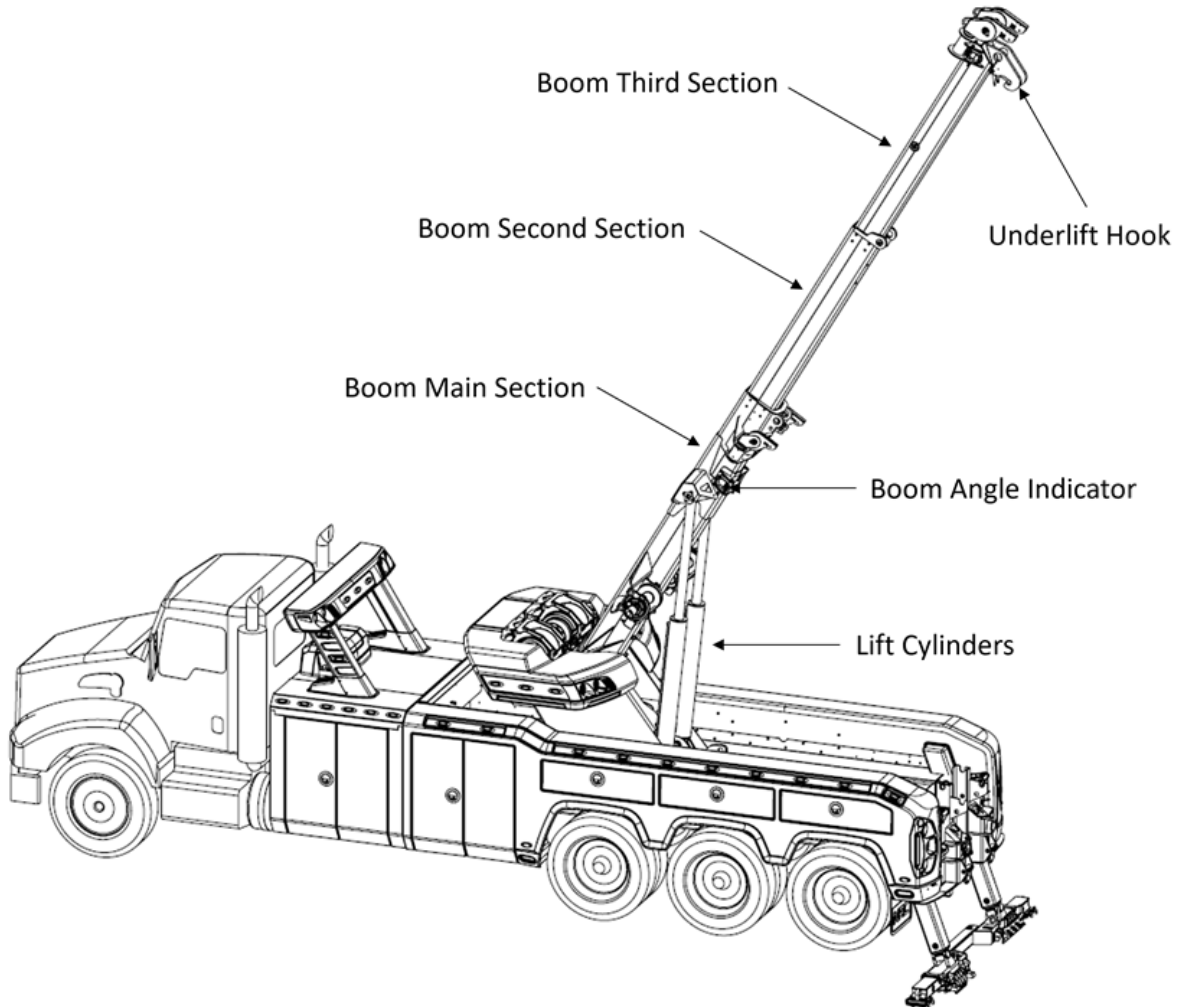

FIGURE 3 – BOOM

1.1.5 Winch

The wrecker is equipped with up to five winches: 2 main winches, 2 auxiliary winches (optional), and 1 drag winch (optional). Figure 1 shows the location of the main and auxiliary winches.

1.1.6 Underlift

The underlift has a vertical section, a horizontal telescopic stinger and a T-bar, as shown in Figure 4. The horizontal stinger can be extended and retracted to allow the T-bar to reach the vehicle to be towed.

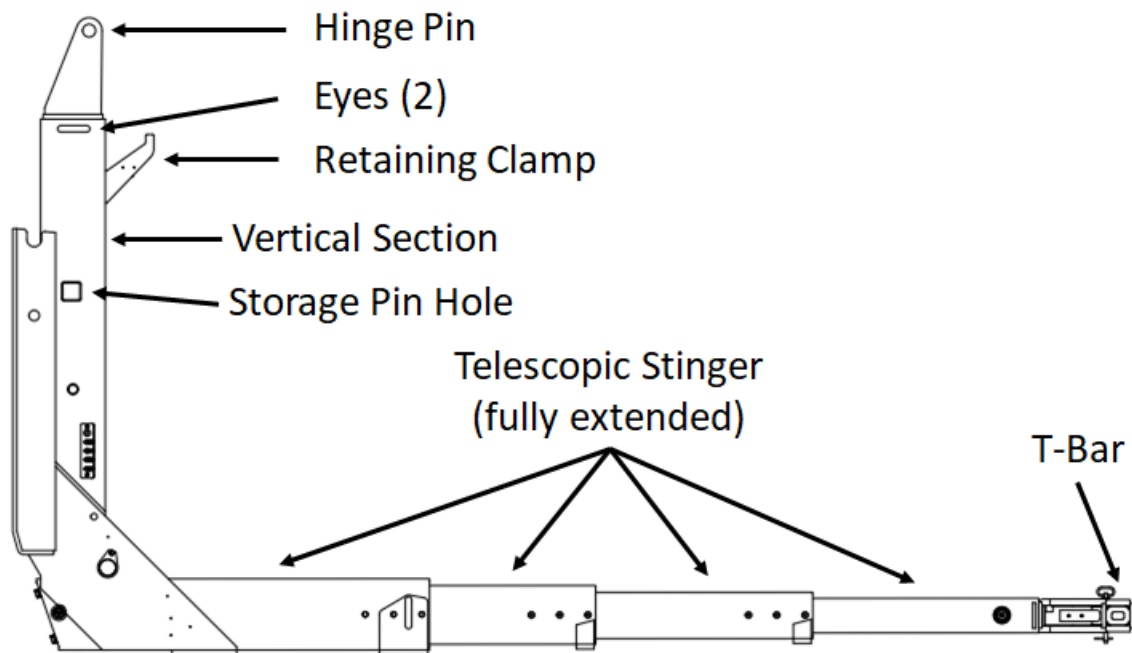

FIGURE 4 – UNDERLIFT

1.1.7 Control panels

The wrecker features two control panels (one on each side) with similar controls. The electronic control panel is located on the driver's side, and the direct-acting mechanical control panel is located on the passenger's side. In France, the electronic control panel is located on the passenger's side, and the mechanical control panel is located on the driver's side.

The wrecker will also have a control panel with a screen on its right if the wrecker has a proportional remote control and a scale system. The scale system adjusts the minimum and maximum boom length and angle values to ensure that the truck remains stable during operation.

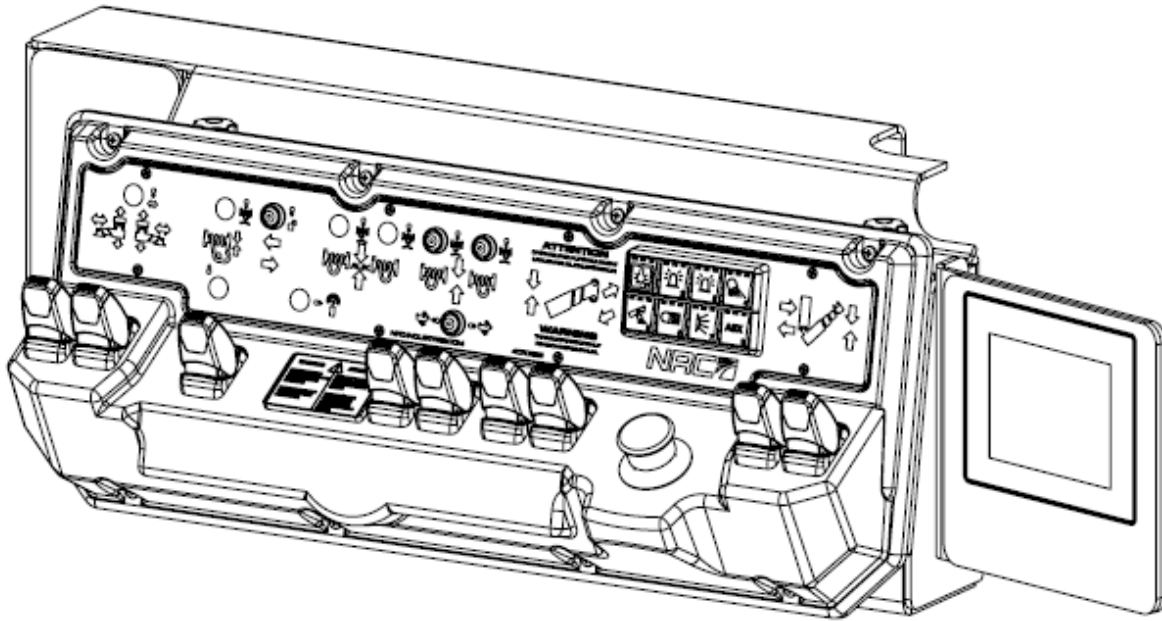

FIGURE 5 – CONTROL PANEL AND SCREEN

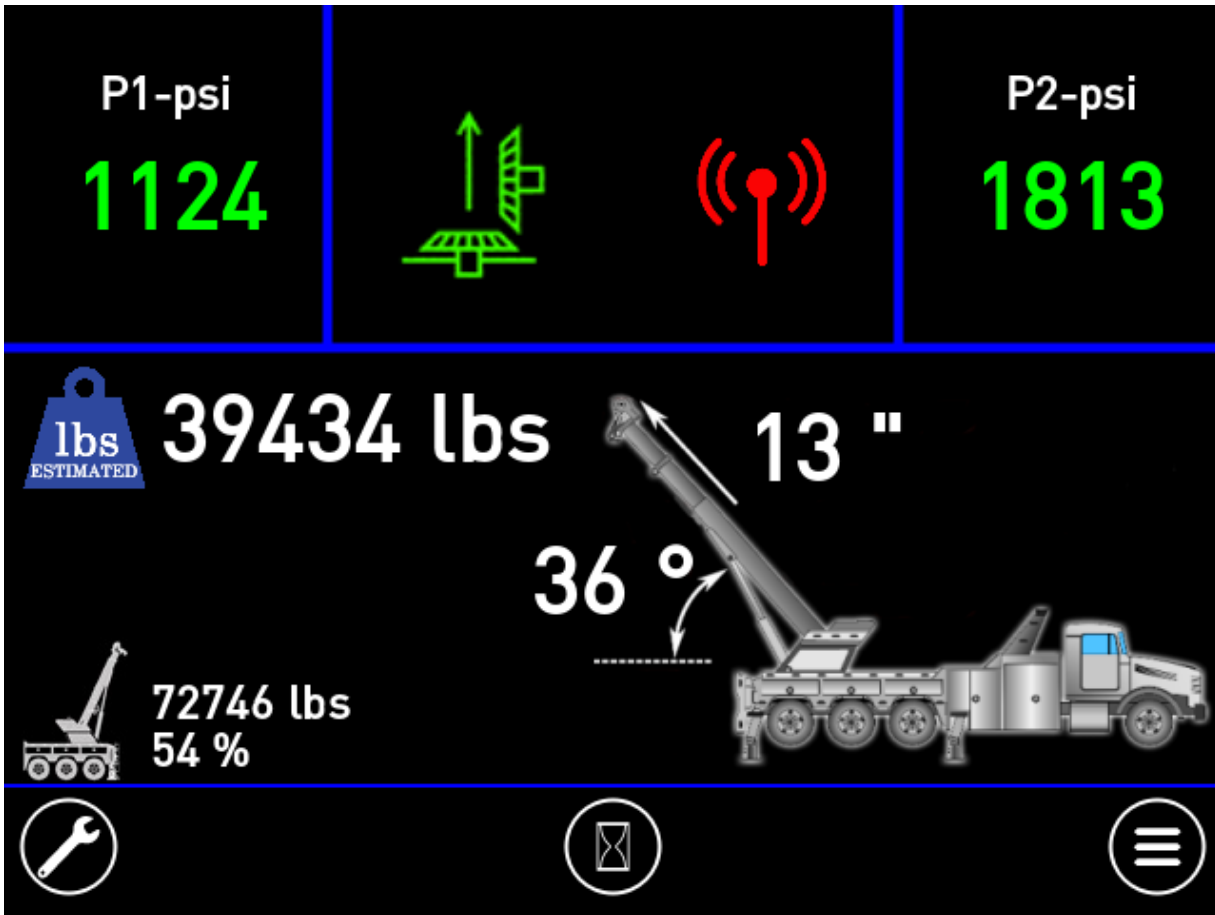

FIGURE 6 – SCREEN (EXAMPLE)

The controls are proportional. This means that speed and power increase with the amount of pressure applied to the levers. Proportional controls allow you to use very slow speeds for greater precision and maximum control of the load.

Figure 7 shows an electronic control panel. Table 1 and Table 2 explain the pictograms used to identify the various controls and switches. These brief descriptions are not operating instructions; to learn how to operate the components, see the procedures in the relevant sections of this manual.

NOTE: The position and number of controls may differ slightly between models.

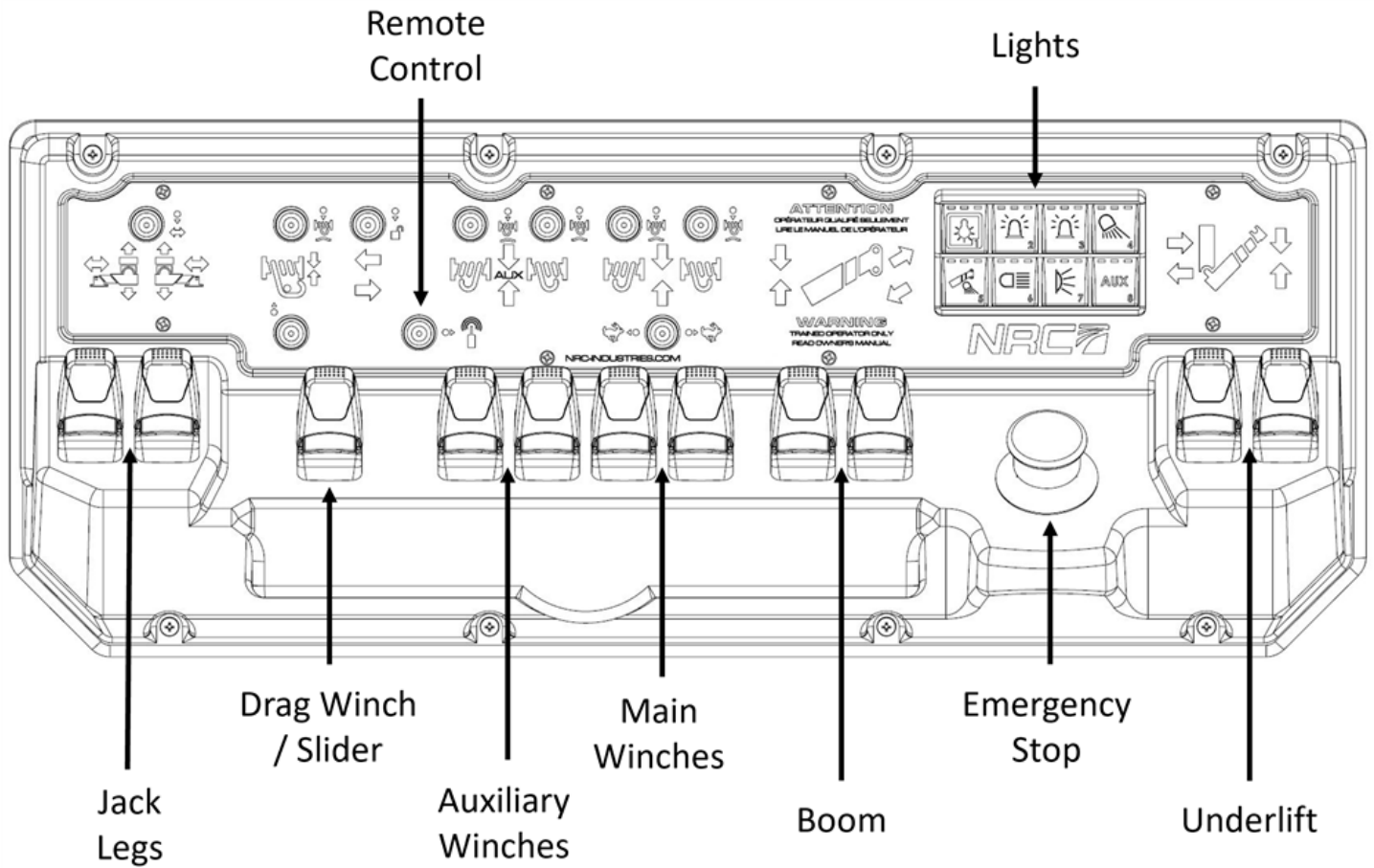







FIGURE 7 – CONTROL PANEL ON THE DRIVER'S SIDE

TABLE 1 – CONTROL PANEL SWITCHES AND BUTTONS

Element	Description
Emergency stop	
	<p>Emergency stop button. Press the emergency stop to halt the machinery. Before restarting the engine, pull the emergency stop button.</p>
Remote control (to operate the remote control, see Section 3.11 Using the remote control with control levers and Section 3.12 Using the remote control that has 6, 10 or 16 function buttons)	
	<p>Remote control on/off button and light. Push the button to activate the remote control. When the light is on, the remote control is on. When the light is off, the remote control is off. When the remote control is on, the control panel is not functional.</p>
Jack legs	
	<p>Jack legs action button and light. Push the button to select the jack legs' action. When the light is on, the levers extend and retract the jack legs. When the light is off, the levers raise and lower the jack legs.</p>
Lights (the indicator above the button is lighted when the light is ON)	
	<p>Toolbox and all lights. Push the button once to turn ON the toolbox lights (the centre indicator will be lit). Push the button a second time to turn ON all lights (the right indicator will be lit). Push the button a third time to turn OFF all lights.</p>
	<p>Emergency lights</p>

















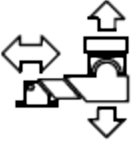

Element	Description
	Strobe
	Lower side work lights
	Boom work lights
	Winch cover work lights
	Rear work lights
<p>AUX</p>	Upper work lights
Winches (to operate the winches, see section 3.10 Using the winch)	
	Left winch (main or aux.) free spool button and light. The left winch is in free spool mode when the light is on.
	Right winch (main or aux.) or drag winch free spool button and light. The right winch (main or aux.) or drag winch is in free spool mode when the light is on.
	High speed button and light. Main winches are in high speed when the light is on.
Slider (to prepare the slider, see section 3.9.1 Preparing the slider)	
	Slider unlock button and light. The slider is unlocked when the light is on.

TABLE 2 – CONTROL PANEL LEVERS

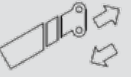
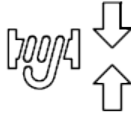
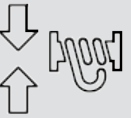
Element	Description
Jack legs (to operate the jack legs, see section 3.7 Using the jack legs)	
	<p>Raises and lowers the left jack leg, or extends and retracts it.</p> <p>Select the jack legs' action using the  button. When the light is on, the levers extend and retract the jack legs.</p>
	<p>Raises and lowers the right jack leg, or extends and retracts it.</p> <p>Select the jack legs' action using the  button. When the light is on, the levers extend and retract the jack legs.</p>
Boom (to operate the boom, see section 3.9 Using the boom)	
	<p>Raises and lowers the boom.</p>
	<p>Extends and retracts the boom.</p>
Winches (to operate the winches, see section 3.10 Using the winch)	
	<p>Winds and unwinds the left main winch cable.</p>
	<p>Winds and unwinds the right main winch cable.</p>
	<p>Winds and unwinds the left auxiliary winch cable.</p>

Element	Description
	Winds and unwinds the right auxiliary winch cable.
	Winds and unwinds the drag winch cable.
Slider (to operate the slider, see section 3.9.2 Sliding the boom)	
	Moves the slider forwards and backwards. Unlock the slider using the  button. The slider is unlocked when the light is on.
Underlift (to operate the underlift, see section 3.8 Using the underlift)	
	Extends and retracts the underlift stinger.
	Folds and unfolds the underlift stinger.

1.1.8 Remote control

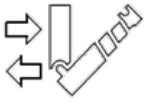
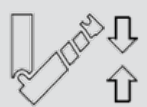
Your wrecker may be equipped with a remote control. The remote control features most of the functions that are available on the main control panels of the wrecker.

Two types of remote controls are available:

- With function buttons
- With control levers

Models with 6, 10, or 16 function buttons

This type of remote control provides non-proportional operation. It may have 6, 10, or 16 function buttons. The function buttons provide most of the hydraulic functions that are available on the main control panel. The functions available vary, depending upon the client requirements.

Figure 8 shows a six-button remote control, and Table 3 explains its functions.

These brief descriptions are not operating instructions; to learn how to operate the components, see the procedures in the relevant sections of this manual.

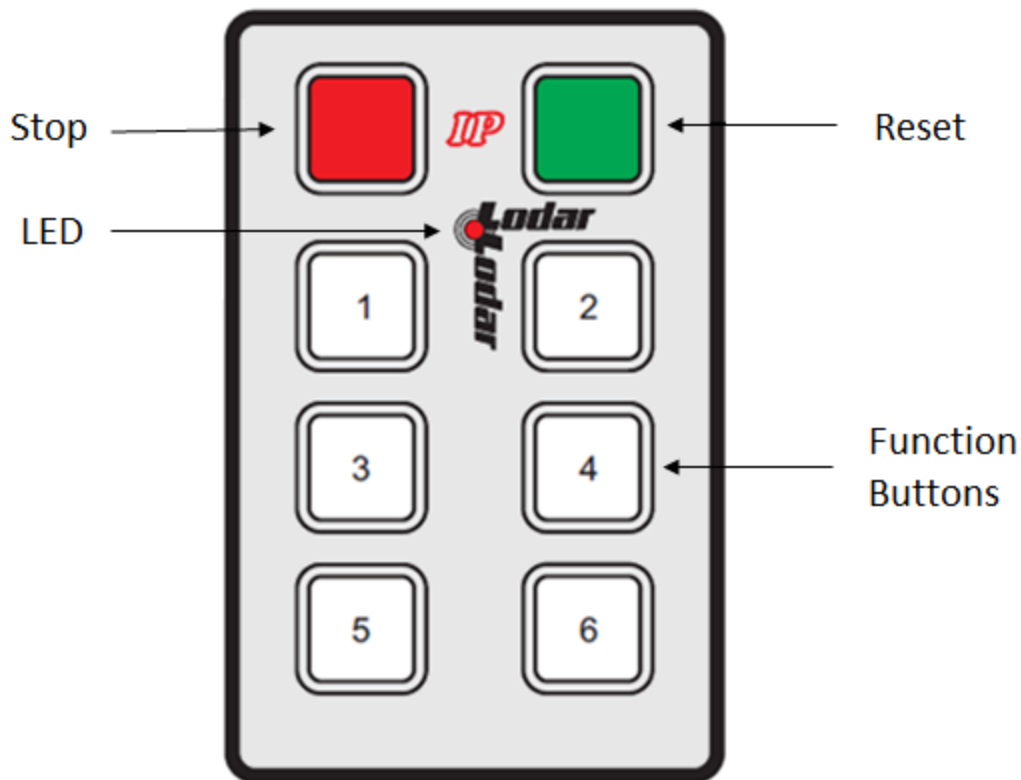

FIGURE 8 – REMOTE CONTROL (SIX FUNCTION BUTTONS SHOWN)

TABLE 3 – REMOTE CONTROL FUNCTIONS

Element	Description
Stop button	Switches off the receiver and the keypad function buttons.
Reset button	Activates the receiver and the keypad function buttons.
LED	Blinks quickly: the transmitter and receiver are active. On: the transmitter button has been pressed and the remote control is transmitting information. Flashes slowly: batteries are low and a button has been pressed.
Function buttons	As specified by the client.

Models with control levers

Figure 9 shows a remote control with control levers, and Table 4 explains the pictograms that are unique to the remote control. The remaining pictograms are also used on the control panels and are therefore explained in Table 1 and Table 2.

These introductory descriptions are not operating instructions; to know how to operate a component, see the procedures in this manual.

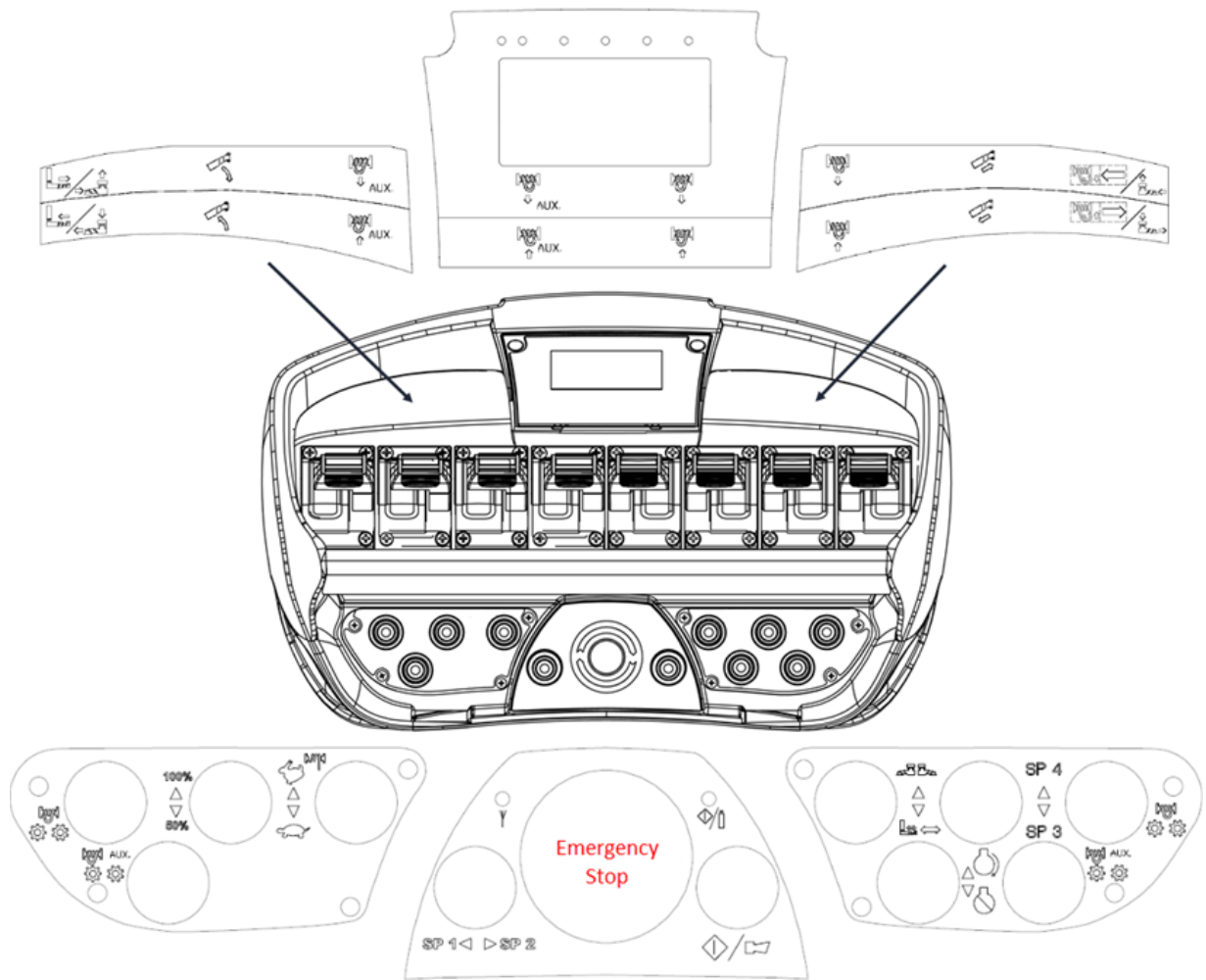
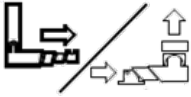
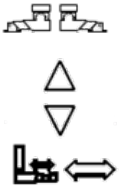

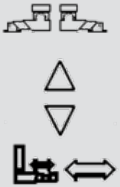

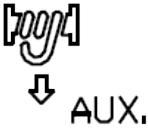

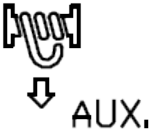













FIGURE 9 – REMOTE CONTROL WITH CONTROL LEVERS



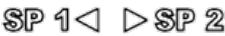



TABLE 4 – REMOTE CONTROL WITH CONTROL LEVERS





The table below shows all possible functions. Your available functions may vary depending on your specific wrecker model and remote control.

Element	Description
	<p>Extends the underlift OR moves the left jack leg. To raise or retract the left jack leg, select one of these settings on the remote control using this button:</p> <ul style="list-style-type: none"> • Raises or lowers the left jack leg • Extends or retracts the left jack leg 
	<p>Retracts the underlift OR moves the left jack leg. To lower or extend the left jack leg, select one of these settings on the remote control using this button:</p> <ul style="list-style-type: none"> • Raises or lowers the left jack leg • Extends or retracts the left jack leg 
	<p>Lowers the boom.</p>
	<p>Raises the boom.</p>
	<p>Unwinds the left auxiliary winch cable.</p>
	<p>Winds the left auxiliary winch cable.</p>

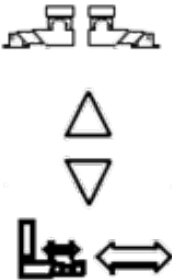
Element	Description
	Unwinds the right auxiliary winch cable.
	Winds the right auxiliary winch cable.
	Unwinds the left main winch cable.
	Winds the left main winch cable.
	Unwinds the right main winch cable.
	Winds the right main winch cable.
	Extends the boom.
	Retracts the boom.

Element	Description
	<p>To select whether to operate the drag winch and the slider, or the right jack leg, use the following button on the remote control.</p> <p>To move the drag winch or boom, select one of these settings on the wrecker's control panel:</p> <ul style="list-style-type: none"> • Moves the boom toward the front of the wrecker (when the slider is unlocked) • Unwinds the drag winch cable <p>To raise or retract the right jack leg, select one of these settings on the wrecker's control panel:</p> <ul style="list-style-type: none"> • Raises or lowers the right jack leg • Extends or retracts the right jack leg
	<p>To select whether to operate the drag winch and the slider, or the right jack leg, use the following button on the remote control.</p> <p>To move the drag winch or boom, select one of these settings on the wrecker's control panel:</p> <ul style="list-style-type: none"> • Moves the boom toward the back of the wrecker (when the slider is unlocked) • Winds the drag winch cable <p>To lower or extend the right jack leg, select one of these settings on the wrecker's control panel:</p> <ul style="list-style-type: none"> • Raises or lowers the right jack leg • Extends or retracts the right jack leg
	<p>Disengages the left main winch.</p>
	<p>Disengages the left auxiliary winch.</p>

Element	Description
	<p>Toggles between half-speed or full-speed operation for all lever functions.</p>
	<p>Toggles between half-speed or full-speed operation for the winches only.</p>
	<p>Spare button.</p>
	<p>When the light is on, the remote control is activated. Activate it on the control panel.</p>
	<p>When the light is on, the remote control is on.</p>
	<p>Turns the remote control on or sounds the horn.</p>
	<p>Toggles between control of the jack legs and control of the slider/drag winch and underlift. Select whether to control the slider or drag winch on the control panel (see Table 2 – Control Panel Levers).</p>

Element	Description
	Starts and stops the engine.
<p data-bbox="250 541 363 590">SP 4</p>  <p data-bbox="250 737 363 785">SP 3</p>	Spare button.
	Disengages the right auxiliary winch.
	Disengages the right main winch.

1.1.9 Hydraulic and pneumatic system

The 30CS, 40CS, and 50CS models feature an electro-hydraulic system that supplies and distributes hydraulic power to the boom, underlift, etc.

1.1.10 Electrical system

The 30CS, 40CS, and 50CS models feature an electrical system that supplies the electrical power for operating the wrecker’s electrical components. The electrical system includes a main electrical panel with breakers and relays that distributes the electricity to the valve banks, electronic control modules, sensors and lights.

1.2 Technical specifications

The following sections list the technical specifications for the components of both wrecker models.

1.2.1 General specifications

TABLE 5 – GENERAL SPECIFICATIONS (IN METRIC [IMPERIAL])

Element	30CS	40CS	50CS
Structural rating	267 kN [30 tons]	356 kN [40 tons]	445 kN [50 tons]
Boom capacity: fully retracted	267 kN [60,000 lb.]*	356 kN [80,000 lb.]**	445 kN [100,000 lb.]***
Boom capacity: fully extended (2nd section)	111 kN [25,000 lb.]*	133 kN [30,000 lb.]**	178 kN [40,000 lb.]***
Boom capacity: fully extended (optional 3rd section)	N/A	67 kN [15,000 lb.]**	89 kN [20,000 lb.]***
Effective reach past tailboard with two-stage boom	4,496 mm [177"]	4,928 mm [194"]	4,953 mm [195"]
Effective reach past tailboard with three-stage boom	N/A	7,290 mm [287"]	7,518 mm [296"]
Maximum working height with two-stage boom	7,493 mm [295"]	8,153 mm [321"]	8,306 mm [327"]
Maximum working height with three-stage boom	N/A	10,211 mm [402"]	10,439 mm [411"]
Boom lifting range	0–60°	0–60°	0–60°
Approximate wrecker weight: excluding chassis	7,250 kg [16,000 lb.]	9,075 kg [20,000 lb.]	10,200 kg [22,500 lb.]
Body width	2,578 mm [101 1/2"]	2,578 mm [101 1/2"]	2,578 mm [101 1/2"]

Element	30CS	40CS	50CS
Minimum distance from back of cab to centre of rearmost axle	3,610 mm [142"]	4,570 mm [180"]	4,570 mm [180"]

- * Capacity @ 50° boom elevation
- ** Capacity @ 60° boom elevation
- *** Capacity @ 55° boom elevation

1.2.2 Chassis

TABLE 6 – CHASSIS SPECIFICATIONS (IN METRIC [IMPERIAL])

Element	30CS	40CS/50CS
Front axle (minimum)	6.5 tons [14,600 lb.]	8.15 tons [18,000 lb.]
Rear axle (minimum)	18 tons [40,000 lb.]	21 tons [46,000 lb.]
Chassis resisting bending moment (RBM) (minimum)	367 kN-m [3,250,000 lb.-in.]	367 kN-m [3,250,000 lb.-in.]

- * Tridem axle required

1.2.3 Dimensions

Figure 10, Figure 11, Table 7 and Table 8 present the dimensions of the wrecker models and their components.

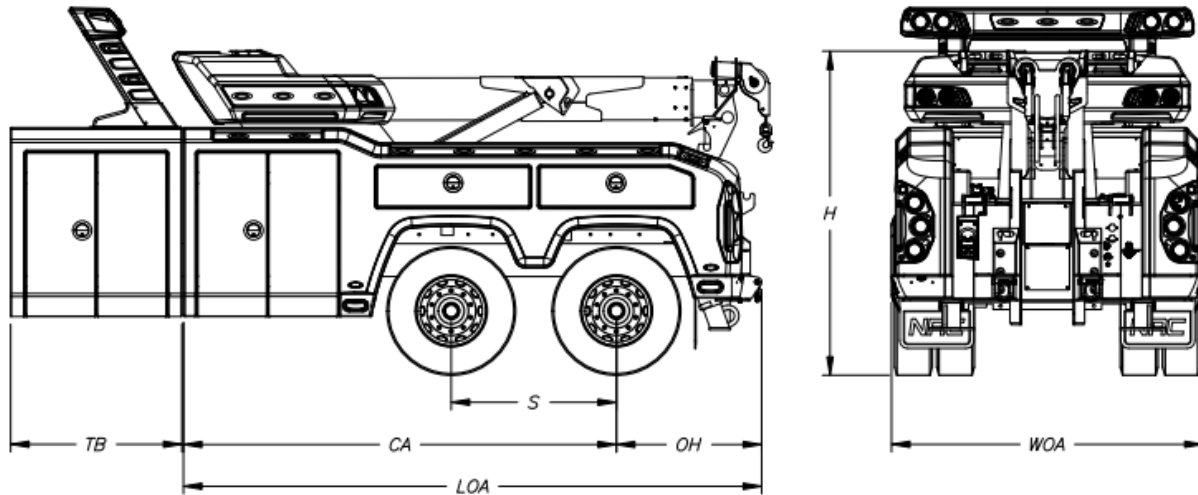

FIGURE 10 – CHASSIS DIMENSIONS (EXAMPLE)

TABLE 7 – CHASSIS DIMENSIONS (IN METRIC [IMPERIAL])

Dimension	30CS Tandem Axle	40CS/50CS Tandem Axle	40CS/50CS Tridem Axle
S	1,372 mm [54"]	1,372 mm [54"]	1,372 mm [54"]
CA (min)	3,708 mm [146"]	4,648 mm [183"]	5,080 mm [200"]
WOA	2,591 mm [102"]	2,591 mm [102"]	2,591 mm [102"]
LOA	4,902 mm [193"]	5,842 mm [230"]	6,274 mm [247"]
OH	1,194 mm [47"]	1,194 mm [47"]	1,194 mm [47"]
TB	710–1,830 mm [28–72"]*	710–1,830 mm [28–72"]*	710–1,830 mm [28–72"]*
H	2,692 mm [106"]	2,946 mm [116"]	2,946 mm [116"]

* In 100 mm [4"] increments

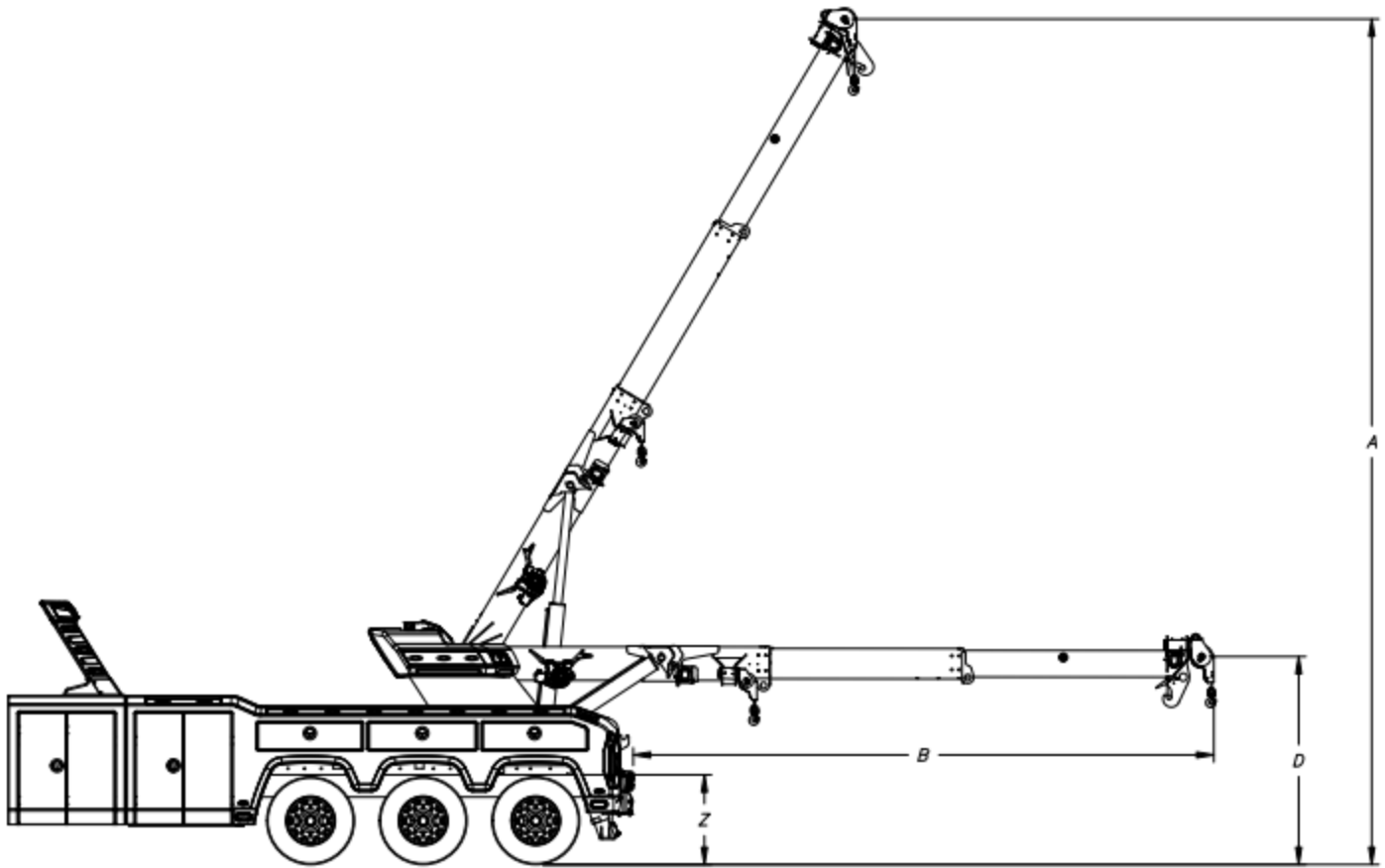

FIGURE 11 – BOOM AND JACK LEGS DIMENSIONS - SIDE VIEW (EXAMPLE)

TABLE 8 – BOOM AND JACK LEGS DIMENSIONS - SIDE VIEW (IN METRIC [IMPERIAL])

Dimension	30CS	40CS	40CS Three-Stage	50CS	50CS Three-Stage
A	7.7 m [25' 4"]	8.4 m [27' 8"]	10.2 m [33' 9"]	8.3 m [27' 3"]	10.3 m [33' 10"]
B	4.2 m [13' 10"]	4.9 m [16' 1"]	7.1 m [23' 2"]	4.7 m [15' 7"]	7.1 m [23' 4"]
D	2.4 m [7' 11"]	2.6 m [8' 5"]	2.5 m [8' 4"]	2.6 m [8' 5"]	2.5 m [8' 4"]
Z	1.1 m [3' 7"]	1.1 m [3' 7"]	1.1 m [3' 7"]	1.1 m [3' 7"]	1.1 m [3' 7"]

1.2.4 Hydraulic system

TABLE 9 – HYDRAULIC SYSTEM SPECIFICATIONS (IN METRIC [IMPERIAL])

Element	30CS	40CS	50CS
Hydraulic pump	Direct mount Double, 12 gpm	Direct mount Double, 12 gpm	Direct mount Double, 12 gpm
Working hydraulic pressure	211 bar [3,000 psi]	211 bar [3,000 psi]	211 bar [3,000 psi]
Slide cylinder stroke	2,032 mm [80"]	2,540 mm [100"]	2,540 mm [100"]
Boom lift cylinder	Dual Ø127 mm [5"]	Dual Ø165 mm [6.5"]	Dual Ø165 mm [6.5"]

1.2.5 Winches and wire ropes

The following tables list the various winches and cables available for each wrecker model, as well as their specifications.

IMPORTANT: NRC equipment uses winches of various brands and models. Always refer to the winch manufacturer manual for information specific to your winch.

⚠ CAUTION

The rated line pulls shown are for the winch only. See the wire rope manufacturer for the wire rope specifications.

As recommended in SAE J959, the strength factor for live or running ropes that wind on drums or pass over sheaves shall be not less than 3.55.

As recommended in EN 14492-1 (ref. 5.15.6), the working coefficient for the first rope layer shall be at least 2.

The winch performance in high speed yields line speeds 2x those charted below, and yields line pulls 1/2x those charted below.

Always be sure that at least 5 full turns of steel winch cable, or 8 full turns of synthetic winch cable (black section of the cable) are wrapped around the winch drum. The friction provided by the wrapped cable allows the drum to pull on the winch cable and move the load.

TABLE 10 – WINCHES AVAILABLE FOR EACH WRECKER MODEL

	Main Winches			Auxiliary Winches		Drag Winch
Capacity kg [lb.]	13,607 [30,000]	18,143 [40,000]	22,679 [50,000]	6,803 [15,000]	9,071 [20,000]	22,679 [50,000]
Type	2-speed planetary			Planetary		
	Wire rope					
Length m [ft.]	61 [200]					109 [360]
Diameter mm [in.]	16 [5/8]	19 [3/4]	22 [7/8]	14 [9/16]	16 [5/8]	19 [3/4]
	Winches available for each wrecker model					
30CS	S	-	-	-	-	-
40CS	-	S	-	O	-	O
50CS	-	-	S	-	O	O
<i>S = standard, O = optional, - = not available</i>						

TABLE 11 - WINCH SPECIFICATIONS OF THE 30CS - 30,000 LB (IN METRIC [IMPERIAL])

Element		Specification				
Winch capacity		133.4 kN [30,000 lb.]				
Wire rope						
Recommended		16 mm x 61 m [5/8" x 200'] 6x36 IWRC EIPS cable				
Working load limit		5,264 kg [11,606 lb]				
Breaking load limit		18,688 kg [41,200 lb]				
Wire rope - EN 14492-1:2006						
Max rope diameter		20 mm				
Minimum rope breaking strength		266.8 kN [60,000 lb.]				
Layer of cable		1	2	3	4	5
Rated line pull per layer Low speed	kg lb.	13,605 [30,000]	11,430 [25,200]	9,840 [21,700]	8,660 [19,100]	7,700 [17,000]
Cable capacity	m ft.	9 [30]	22 [75]	36 [120]	53 [175]	71 [235]
Line speed (at 17 gpm/64.3 Lpm) Low speed	MPM FPM	5.7 [19]	7.0 [23]	7.9 [26]	8.8 [29]	10.0 [33]

TABLE 12 - WINCH SPECIFICATIONS OF THE 40CS - 40,000 LB (IN METRIC [IMPERIAL])

Element		Specification				
Winch capacity		177.9 kN [40,000 lb.]				
Wire rope						
Recommended		19 mm x 61 m [3/4" x 200'] EIPS cable				
Working load limit		7,512 kg [16,563 lb]				
Breaking load limit		26,308 kg [58,800 lb]				
Wire rope - EN 14492-1:2006						
Max rope diameter		20 mm				
Minimum rope breaking strength		355.8 kN [80,000 lb.]				
Layer of cable		1	2	3	4	5
Rated line pull per layer Low speed	kg lb.	18,100 [40,000]	15,100 [33,500]	13,000 [28,800]	11,400 [25,300]	10,200 [22,500]
Cable capacity	m ft.	7 [25]	16 [55]	28 [95]	41 [135]	56 [185]
Line speed (at 17 gpm/64.3 Lpm) Low speed	MPM FPM	4.8 [16]	5.6 [18.7]	6.3 [21]	7.2 [24]	8.2 [27]

TABLE 13 - WINCH SPECIFICATIONS OF THE 50CS - 50,000 LB. (IN METRIC [IMPERIAL])

Element		Specification				
Winch capacity		222 kN [50,000 lb.]				
Wire rope - North America						
Recommended		22 mm x 61 m [7/8" x 200'] EIPS 1960 IWRC				
Working load limit		10,170 kg [22,420 lb.]				
Breaking load limit		36,105 kg [79,600 lb.]				
Wire rope - EN 14492-1:2006						
Max rope diameter		22 mm				
Minimum rope breaking strength		445 kN [100,000 lb.]				
Layer of cable		1	2	3	4	5
Rated line pull per layer Low speed ¹	kg lb	18,100 [50,000]	15,100 [41,400]	13,000 [35,300]	11,400 [30,700]	10,200 [27,200]
Cable capacity ¹	m ft	7 [25]	16 [55]	28 [95]	41 [135]	56 [185]
Line speed (at 17 GPM) Low speed ¹	MPM FPM	4.8 [16]	5.6 [18.7]	6.3 [21]	7.2 [24]	8.2 [27]

Note 1: Based on 22 mm [7/8"] wire rope.

1.2.6 Underlift dimensions and capacity

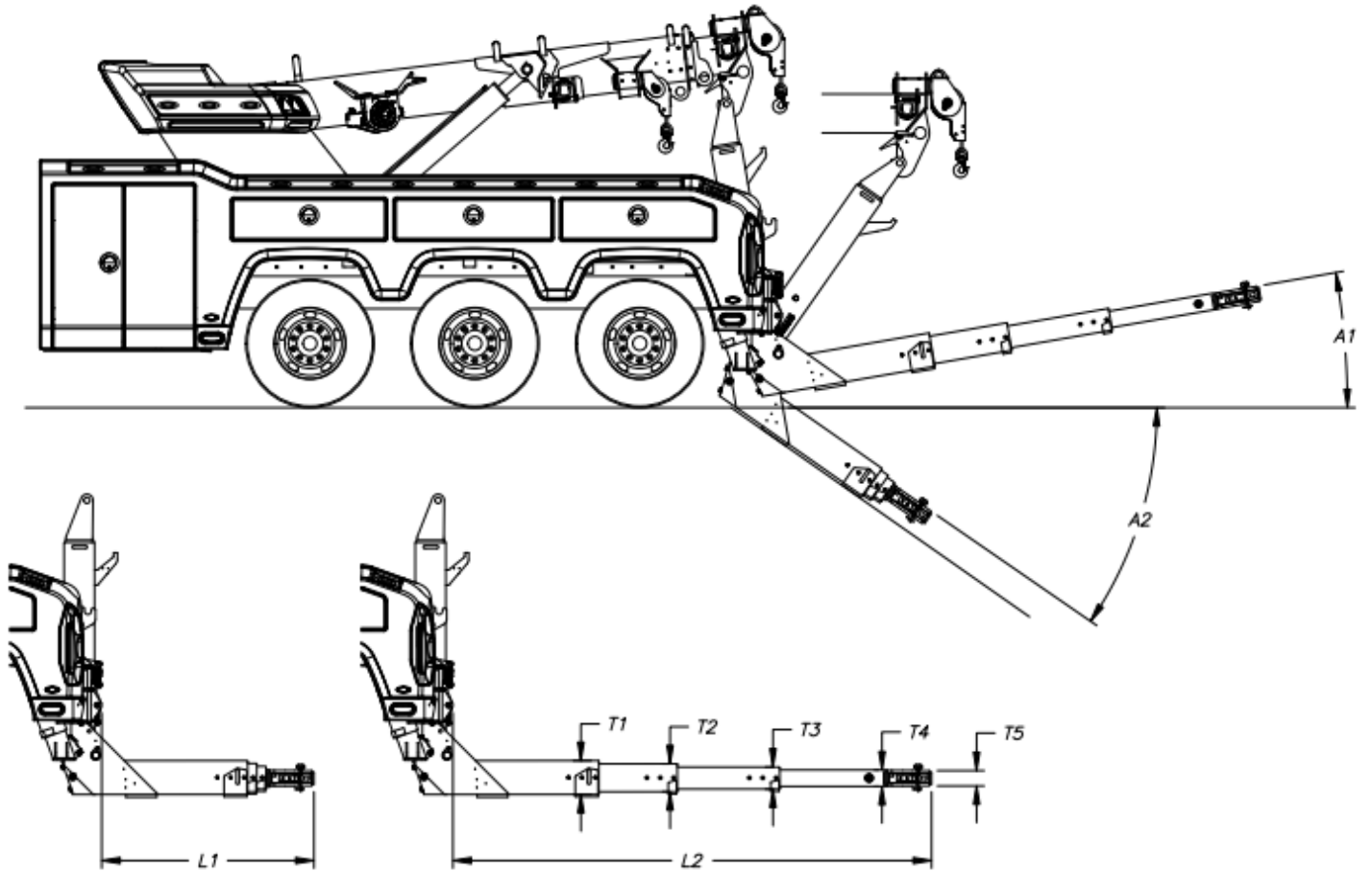

FIGURE 12 – UNDERLIFT DIMENSIONS

TABLE 14 – UNDERLIFT DIMENSIONS AND CAPACITY (IN METRIC (MM) [IMPERIAL (IN)])

NOTE: Underlift specifications are based on the static structural rating.

Dimension	HD-3	HDE-3	SHD-3	LSHDE-3	XSHDE-3	SSHD-4	LSHD-4
A1	8°	8°	9°	8°	8°	9°	9°
A2	14°	17°	11°	17°	17°	14°	14°
L1	1,784 mm [70.3"]	1,895 mm [74.6"]	2,089 mm [82.3"]	2,040 mm [80.3"]	2,222 mm [87.5"]	1,829 mm [72"]	2,100 mm [82.7"]
L2	2,759 mm [108.6"]	3,670 mm [144.5"]	3,340 mm [131.5"]	3,648 mm [143.6"]	4,210 mm [165.8"]	3,679 mm [144.8"]	4,323 mm [170.2"]
Reach (L2-L1)	975 mm [38.3"]	1,775 mm [69.9"]	1,251 mm [49.2"]	1,608 mm [63.3"]	1,988 mm [78.3"]	1,850 mm [72.8"]	2,223 mm [87.5"]
T1	203 mm [8"]	210 mm [8.3"]	254 mm [10"]	235 mm [9.3"]	235 mm [9.3"]	281 mm [11.1"]	281 mm [11.1"]
T2	153 mm [6"]	170 mm [6.7"]	203 mm [8"]	189 mm [7.4"]	189 mm [7.4"]	235 mm [9.3"]	235 mm [9.3"]
T3	127 mm [5"]	133 mm [5.3"]	152 mm [6"]	146 mm [5.8"]	146 mm [5.8"]	189 mm [7.4"]	189 mm [7.4"]
T4	N/A	N/A	N/A	N/A	N/A	146 [5.8"]	146 [5.8"]
T5	195 mm [7.7"]	135 mm [5.3"]	195 mm [7.7"]	135 mm [5.3"]	135 mm [5.3"]	195 mm [7.7"]	195 mm [7.7"]
Towing capacity	356 kN [80,000 lb]	356 kN [80,000 lb]	400 kN [90,000 lb]	400 kN [90,000 lb]	400 kN [90,000 lb]	356 kN [80,000 lb]	356 kN [80,000 lb]

Dimension	HD-3	HDE-3	SHD-3	LSHDE-3	XSHDE-3	SSHD-4	LSHD-4
Lifting capacity when extended	67 kN [15,000 lb]	71 kN [16,000 lb]	89 kN [20,000 lb]	89 kN [20,000 lb]	89 kN [20,000 lb]	102 kN [23,000 lb]	89 kN [20,000 lb]
Lifting capacity when retracted	156 kN [35,000 lb]	156 kN [35,000 lb]	222 kN [50,000 lb]	222 kN [50,000 lb]	222 kN [50,000 lb]	311 kN [70,000 lb]	267 kN [60,000 lb]

1.2.7 Lifting capacity

Lifting capacities are presented in the following order:

- Figure 13 — Lifting Capacity of the 30CS
- Figure 14 — Lifting Capacity of the 40CS
- Figure 14 — Lifting Capacity of the 40CS

30CS

XX.X - BASED ON STRUCTURAL STRENGTH
- BASÉ SUR LA LIMITE STRUCTURELLE

XX.X - BASED ON STABILITY (80% OF TIPPING)
- BASÉ SUR 80% DE LA LIMITE DE STABILITÉ

• APPLIES WHEN / APPLICABLE QUAND :

- WORKING ON SOLID GROUND LEVEL / LA SURFACE EST COMPACTE ET SOLIDE
- EQUIPMENT WEIGHT / LA MASSE EST DE : 45 000lb (20 411kg)
- WB / L'EMPATTEMENT EST DE : 296" (7.5 METRES)

• SLIGHT CHANGES IN CAPACITY AND LOAD POSITIONS MAY OCCUR WITH DIFFERENT TRUCK MODELS AND OPTIONS.

LES CAPACITÉS DE LEVAGE AINSI QUE LA DISTANCE DES CHARGES PEUVENT VARIER SELON LES OPTIONS ET LE MODÈLE DE CAMION.

• USE LOADS FOR THE LONGER BOOM LENGTH WHEN THE BOOM LENGTH IS BETWEEN THE POINT SHOWN ON THE CHART.

UTILISER LE CHARGEMENT POUR LA LONGUEUR DE MAT SUPÉRIEUR LORSQUE LA LONGUEUR DU MAT SE TROUVE ENTRE LES POINTS DE LA CHARTE.

• USE LOADS FOR THE SMALLER BOOM ANGLE WHEN THE BOOM ANGLE IS BETWEEN THE POINT SHOWN ON THE CHART.

UTILISER LE CHARGEMENT POUR L'ANGLE DE MAT INFÉRIEUR LORSQUE L'ANGLE DU MAT SE TROUVE ENTRE LES POINTS DE LA CHARTE.

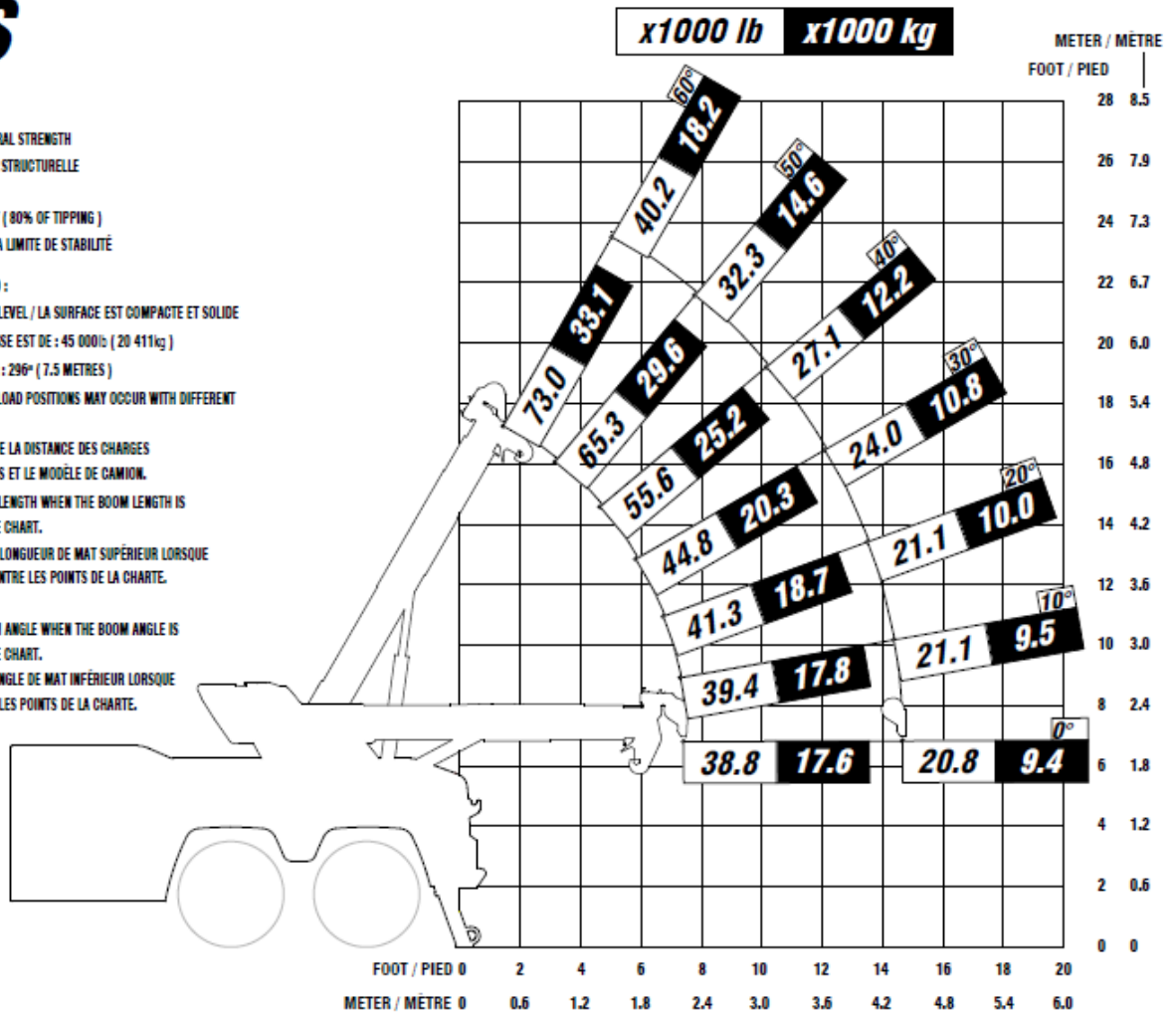

FIGURE 13 — LIFTING CAPACITY OF THE 30CS

40CS

XX.X - BASED ON STRUCTURAL STRENGTH
- BASÉ SUR LA LIMITE STRUCTURELLE

XX.X - BASED ON STABILITY (80% OF TIPPING)
- BASÉ SUR 80% DE LA LIMITE DE STABILITE

- APPLIES WHEN / APPLICABLE QUAND :
 - WORKING ON SOLID GROUND LEVEL / LA SURFACE EST COMPACTE ET SOLIDE
 - EQUIPMENT WEIGHT / LA MASSE EST DE : 45 000lb (20 411kg)
 - WB / L'EMPATTEMENT EST DE : 296" (7.5 METRES)

• SLIGHT CHANGES IN CAPACITY AND LOAD POSITIONS MAY OCCUR WITH DIFFERENT TRUCK MODELS AND OPTIONS.
LES CAPACITES DE LEVAGE AINSI QUE LA DISTANCE DES CHARGES PEUVENT VARIER SELON LES OPTIONS ET LE MODELE DE CAMION.

• USE LOADS FOR THE LONGER BOOM LENGTH WHEN THE BOOM LENGTH IS BETWEEN THE POINT SHOWN ON THE CHART.
UTILISER LE CHARGEMENT POUR LA LONGUEUR DE MAT SUPERIEUR LORSQUE LA LONGUEUR DU MAT SE TROUVE ENTRE LES POINTS DE LA CHARTE.

• USE LOADS FOR THE SMALLER BOOM ANGLE WHEN THE BOOM ANGLE IS BETWEEN THE POINT SHOWN ON THE CHART.
UTILISER LE CHARGEMENT POUR L'ANGLE DE MAT INFÉRIEUR LORSQUE L'ANGLE DU MAT SE TROUVE ENTRE LES POINTS DE LA CHARTE.

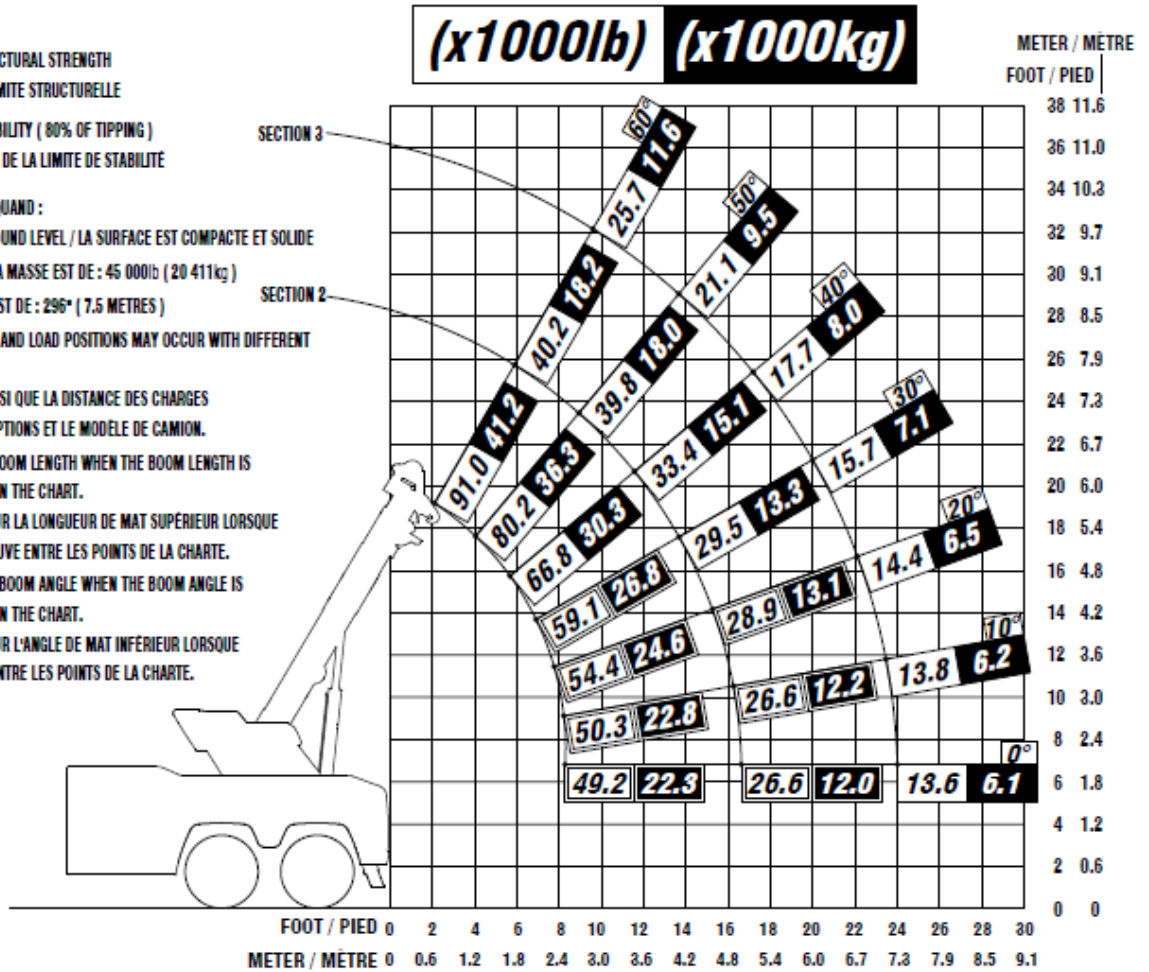

8190211

FIGURE 14 – LIFTING CAPACITY OF THE 40CS

50CS

XX.X - BASED ON STRUCTURAL STRENGTH
 - BASÉ SUR LA LIMITE STRUCTURELLE

XX.X - BASED ON STABILITY (80% OF TIPPING)
 - BASÉ SUR 80% DE LA LIMITE DE STABILITE

- APPLIES WHEN / APPLICABLE QUAND :
 - WORKING ON SOLID GROUND LEVEL / LA SURFACE EST COMPACTE ET SOLIDE
 - EQUIPMENT WEIGHT / LA MASSE EST DE : 45 000lb (20 411kg)
 - WB / L'EMPATTEMENT EST DE : 296" (7.5 METRES)

• SLIGHT CHANGES IN CAPACITY AND LOAD POSITIONS MAY OCCUR WITH DIFFERENT TRUCK MODELS AND OPTIONS.
 LES CAPACITES DE LEVAGE AINSI QUE LA DISTANCE DES CHARGES PEUVENT VARIER SELON LES OPTIONS ET LE MODELE DE CAMION.

• USE LOADS FOR THE LONGER BOOM LENGTH WHEN THE BOOM LENGTH IS BETWEEN THE POINT SHOWN ON THE CHART.
 UTILISER LE CHARGEMENT POUR LA LONGUEUR DE MAT SUPERIEUR LORSQUE LA LONGUEUR DU MAT SE TROUVE ENTRE LES POINTS DE LA CHARTE.

• USE LOADS FOR THE SMALLER BOOM ANGLE WHEN THE BOOM ANGLE IS BETWEEN THE POINT SHOWN ON THE CHART.
 UTILISER LE CHARGEMENT POUR L'ANGLE DE MAT INFERIEUR LORSQUE L'ANGLE DU MAT SE TROUVE ENTRE LES POINTS DE LA CHARTE.

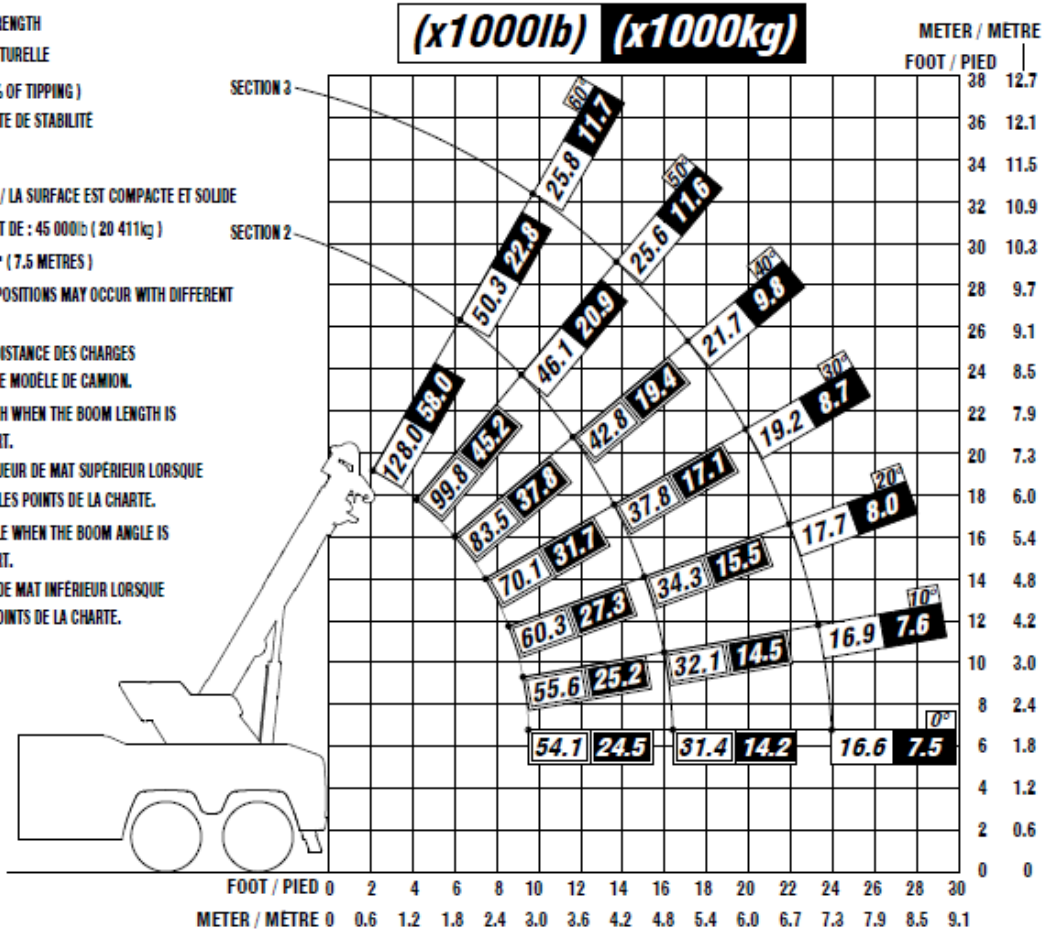

8190210

FIGURE 15 – LIFTING CAPACITY OF THE 50CS

2 SAFETY

2.1 General

⚠ DANGER

Safety must be your top priority when operating and maintaining this equipment. Improper use of this equipment is dangerous. Failure to comply with the safety guidelines in this manual can cause accidents that may result in material damage, injury or even death.

Should you find that this manual contains insufficient or unclear information about equipment operation and maintenance, please contact your nearest NRC distributor for more details (see the Authorized distributors and service providers section).

2.2 Safety labels

Ensure that all DANGER, WARNING, CAUTION and other labels and lifting capacity charts are legible and properly placed. Clean and replace them as needed.

2.3 Intended use

NRC Industries equipment is intended for use only by trained and qualified operators who have carefully read and understood the contents of this manual.

This product was designed to recover and tow vehicles that do not exceed its lift or tow ratings.

This manual explains how to properly use the towing equipment. However, you should also refer to the towing recommendations from the vehicle manufacturer or a certified towing manual to learn about recovery procedures for the vehicle to be towed.

⚠ DANGER

This equipment was not designed for lifting persons and must never be used for that purpose.

2.4 NRC responsibilities

IMPORTANT: NRC Industries Inc. rejects any claim that may result from the incorrect or unlawful application of its equipment.

NRC recommends that the wrecker mounting plates be inspected every three months by an authorized NRC distributor. Should a visual inspection identify any cracks or structural damage, immediately discontinue use until the equipment is deemed safe.

NRC recommends that the hydraulic system of the wrecker be checked at least once a year, **ONLY** by an authorized NRC distributor.

Wreckers must not be modified without prior authorization from NRC Industries. Any unauthorized modifications may void the warranty.

2.5 Supervisory responsibilities

A full understanding of this manual is essential to safely operate and maintain this equipment. Ensure that all operators carefully read and understand this manual before allowing them to operate or maintain the equipment or any of its parts. Once operators have read and understood the manual, have them sign the Operator record at the end of this manual.

A PIN code issued by NRC Industries is needed to access certain factory settings in the electronic control system. Give the PIN code for unlocking the console **ONLY** to trained personnel who understand the importance of not modifying the settings, since they can affect equipment operation.

Equipment manufactured by NRC Industries is intended for use by towing and recovery professionals, and not unqualified or untrained individuals. The equipment should not be loaned or rented to anyone lacking the required skills.

NRC recommends fitting **ALL** tow trucks with beacons or other lights to signal their presence and comply with local regulations.

2.6 Operator responsibilities

Read and understand this manual before attempting to operate or maintain your equipment. Read all the warning labels and exercise good judgment and common sense while using the equipment.

Never operate this equipment under the influence of drugs or alcohol.

EMERGENCIES: Use the emergency stop to immediately stop the machine.

2.6.1 Wear protective clothing

Always wear protective gloves.

Wear a hard hat and safety footwear when walking on the wrecker deck.

Wear long sleeves, bright-coloured clothing with reflective strips, work gloves, and safety boots.

Wear safety goggles.



2.6.2 Follow safety rules

Before driving the vehicle, check that the power take-off (PTO) is disengaged:

- The control levers should no longer be functional.
- The warning light in the cab should be off.

Never tow a vehicle that has people inside.

Never exceed equipment or chassis ratings. This could cause injury and/or damage the equipment.

Always use safety chains when towing.

Only suspend loads from the winch cables. Applying a load to the vehicle by another means is strictly prohibited.

If the equipment controls are too near traffic or a potential hazard, use the remote control and keep your distance.

When operating the vehicle on the roadside or in any dangerous area, select the controls situated away from the danger or traffic to ensure maximum safety.

When the vehicle is not in use, ensure that the PTO is disengaged.

Inspect the cables regularly and replace any worn or damaged ones.

2.6.3 Avoid danger zones

The area underneath the lifting device is a DANGER ZONE and must never be entered.

To avoid getting wrapped or tangled, keep away from the places where:

- The winch cables pass through the fairlead at the end of the boom.
- The winch cables wind onto the boom.

Always keep clear of winches and cables. Although the relatively low speed of the winches will keep any risks to a minimum, stay away from cables at all times — regardless of whether they are moving or stationary, taut or loose. Never step over a cable or chain, whether it is taut or not.

2.6.4 Set up a safety perimeter

Always set up a safety perimeter at least 45 m (150') in diameter around the equipment and any load or vehicle. Do not allow anyone to enter this danger zone when you are using the equipment.

In addition, do not allow anyone within 75 m (250') of a winch cable.

2.7 Conditions for use

2.7.1 Risk of electric shock

The wrecker is not insulated and offers no protection against electric currents.

- Never operate the wrecker in places where power lines, underground cables or other energy sources may exist unless the power company has turned off the power. If working in the dark, use adequate lighting to look for power lines.
- Always check for power lines before using the boom and ensure that it does not come into contact with power lines.
- Keep a safe distance away from the power lines.
- Do not touch or get out of an energized vehicle.
- Avoid raising the boom during a thunderstorm, since it could attract lightning.
- Maintain at least 3 m (10') of clearance between all wrecker parts and power lines or devices with more than 50,000 volts. See the minimum approach distances in the table and add an additional 30 cm (1') for every 30,000 volts or portion thereof.

Minimum Approach Distance (M.A.D.)

Voltage Range (Phases to Phase)	MINIMUM APPROACH DISTANCE
0 kV to 50 kV	10 ft. (3 m)
Over 50 kV to 200 kV	15 ft. (5 m)
Over 200 kV to 350 kV	20 ft. (6 m)
Over 350 kV to 500 kV	25 ft. (8 m)
Over 500 kV to 750 kV	35 ft. (11 m)
Over 750 kV to 1,000 kV	45 ft. (14 m)
<i>NOTE: This requirement shall apply except where employer, local or government regulations are more stringent.</i>	

- The minimum approach distance can be reduced if insulating barriers are installed and are rated for the power line in question. These barriers must not be part of (or attached to) the wrecker. The minimum approach distance must be reduced based on the dimensions provided by the insulating barrier design. The reduced distance must be calculated by a qualified individual in compliance with employer, local, regional or national requirements for work near electrical equipment.

⚠ DANGER

All persons and wrecker parts must remain at the minimum approach distance from energized power lines or equipment. When in doubt, always assume that the power line or equipment is energized.

2.7.2 Hazardous winds

Never do any lifting when winds put personnel, the public or property at risk. Evaluate the size and shape of the load to determine whether the wind could cause problems. For example, even though the load weight may be within capacity, heavy winds and gusts can catch any large surfaces and cause them to twist or become out of control during lifting. Swinging and spinning loads pose a risk to the rigging and may potentially overload the lifting equipment.

2.7.3 Slipping and tipping hazards

Place the wrecker on a stable and level surface.

If the ground is not level, level the truck.

Use extra caution when operating the wrecker on icy surfaces. Use the outriggers and spades to prevent the wrecker from slipping.

2.7.4 Obstacle clearance distance

Keep all loads a safe distance away from surrounding obstacles.

3 OPERATION

This chapter describes how to operate your wrecker, which involves using many functions and components simultaneously. To take advantage of all the capabilities of your wrecker, you must first understand the general operating principles.

3.1 Operating principles

⚠ DANGER

Your wrecker is a powerful machine. Always think about what you are about to do before operating the equipment and ensure that you apply general vehicle equilibrium and stability principles as described in this section. For lifting capacities, see 1.2.7 Lifting capacity. Lifting a load that exceeds the specified lifting capacities can damage the equipment or cause it to tip over.

FAILURE TO FOLLOW THESE INSTRUCTIONS CAN RESULT IN THE EQUIPMENT TIPPING OVER, WHICH CAN CAUSE PROPERTY DAMAGE, INJURIES OR EVEN DEATH.

The general principles to understand before operating the machine are as follows:

1. The more you extend the boom, the less weight you will be able to lift with it.
2. When winching, the higher you raise the boom, the longer the lever is and the sooner the truck will tip backward. However, lifting the boom will provide more grip on the ground as it will put more pressure on the jack legs. You can use a different boom angle when pulling, depending on the load weight and position.
3. Any weight applied to the tow truck behind the rear axle will bear directly on this rear axle. The rear axle also bears some weight transferred from the front axle. Therefore, for a given load on the underlift, the pressure exerted on the ground by the rear axle will be greater than that the pressure from the load alone.
4. The more the underlift is extended so that the load is further away from the tow truck, the greater will be the load transfer from the front to rear.
5. The more winch cable you unwind, the more pulling force you have to tow the vehicle.
6. You can use pulleys to increase the winch capacity.

3.1.1 Calculating the load on each axle

You can calculate the load on each axle of the tow truck. Generally speaking, if you tow another vehicle with the underlift fully extended, the maximum load will be on the rear axle, and very little load on the front axle.

IMPORTANT: Make sure the load on each axle does not exceed the axle capacity and meets the local regulations. The combined weight of the tow truck and towed vehicle must not exceed the gross vehicle weight rating.

To calculate the residual load on the front axle, or to calculate the total load on the rear axle group, you need to know the following, which are also illustrated in Figure 16:

- Empty weight at the front axle. This value varies for each vehicle; you must weigh your own vehicle to know this exact value.
- Empty weight at the rear axle. This value varies for each vehicle; you must weigh your own vehicle to know this exact value.
- Distance from the T-bar to the centre of the tandem axle¹. You need to measure this.
- Distance between the front axle and the rear tandem axle (or wheelbase).
- Load on the underlift.

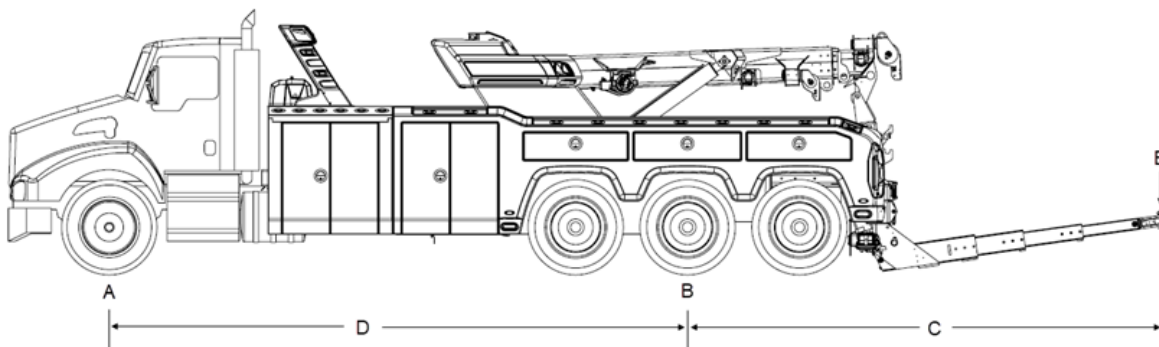

FIGURE 16 – AXLE LOAD CALCULATIONS

¹If the rear axle group is composed of a single drive axle and a liftable pusher axle, this calculation does not apply. Contact your NRC representative for more details.

On the front axle

Use the following formula to calculate the residual load on the front axle (RLFA)¹:

$$\frac{E \times C}{D} = F$$

$$RLFA = A - F$$

For example, if you have the following values:

- A. 12,000 lb.
- B. 15,000 lb.
- C. 100"
- D. 300"
- E. 15,000 lb.

You will get the following residual load on the front axle:

$$F = (E \times C) / D = (15,000 \times 100") / 300" = 5,000 \text{ lb.}$$

$$RLFA = A - F = 12,000 - 5,000 = 7,000 \text{ lb.}$$

¹Source: *Les Dépanneuses: équipement de base, utilisation, lois, normes et règlements*, Sainte-Foy, Québec: Publication du Québec, 1996 (in French).

On the rear axle

Use the following formula to calculate the total load on the rear axle (TLRA)¹:

$$\frac{E \times C}{D} = F$$

$$\text{TLRA} = B + E + F$$

For example, if you have the following values:

- A. 12,000 lb.
- B. 15,000 lb.
- C. 100"
- D. 300"
- E. 15,000 lb.

You will get the following total load on the rear axle:

$$F = (E \times C) / D = (15,000 \times 100") / 300" = 5,000 \text{ lb.}$$

$$\text{TLRA} = B + E + F = 15,000 + 15,000 + 5,000 = \mathbf{35,000 \text{ lb.}}$$

3.1.2 Maximizing the pulling capacity of the winch

Winches have more pulling force when more cable is unwound. To maximize the pulling force, unwind the cable so that only one layer remains on the winch drum. This will give you the maximum pulling force.

IMPORTANT: Make sure to keep at least 5 turns of cable on the winch drum for steel cable, or 8 turns for synthetic cable.

¹Source: *Les Dépanneuses: équipement de base, utilisation, lois, normes et règlements*, Sainte-Foy, Québec: Publication du Québec, 1996 (in French).

NOTE: See Section 1.2.5 Winches and wire ropes or the manual provided by the winch manufacturer for information about pulling force versus the number of layers of cable remaining on the drum.

3.1.3 Increasing winch capacity with pulleys

If you need to pull a load that exceeds the safe working limit of the wire or synthetic rope, you can reduce line tension and increase pulling capacity using blocks. Use a running block tackle and an anchor to pull the load as shown in Figure 17 to double the pulling force. You need to factor in veer angle and friction loss in the blocks, which can be up to 10% for poorly-maintained/lubricated blocks.

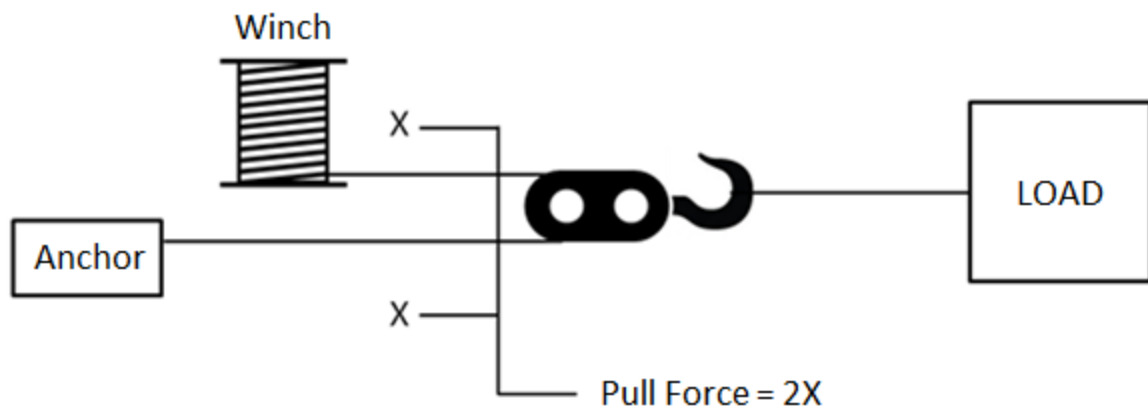

FIGURE 17 – CALCULATING INCREASED WINCH CAPACITY

You can calculate the total winch-pulley-anchor capacity using this formula:

$$\text{Winch-pulley-anchor pull force} = 90\% \text{ of } (2 \times X)$$

Where X = winch capacity

For $X = 20,000 \text{ lb.}$

$$\text{Total pull force} = 90\% \text{ of } (2 \times 20,000 \text{ lb.}) = 36,000 \text{ lb.}$$

3.2 Preparing the wrecker for optimal performance

Position the wrecker on a flat, solid surface with the rear as close as possible to the load. Ensure that you have sufficient reach and lifting capacity to safely proceed (see Section 1.2.7 Lifting capacity).

If the load weight is close to the capacity of your wrecker, you can move the load and wrecker closer together by removing the underlift from the wrecker chassis (see Section 3.8.5 Removing the underlift from the wrecker). Moving the wrecker closer to the load allows you to retract the boom and thereby increase the boom's lifting capacity.

Lifting a heavy load places significant weight on each jack leg. Ensure that the ground is solid enough to prevent the jack legs from sinking.

⚠ DANGER

Risk of tipping the wrecker. Ensure that ONLY the jack leg feet touch the ground. If any other jack leg parts touch the ground, the wrecker will be unstable.

Decide whether to keep the underlift in place or remove it from the wrecker chassis and put it on the ground. The boom has a limited field of movement when the underlift is attached. The boom's hydraulic lift cylinders may come into contact with the top of the underlift stinger when it is lowered and slid to the rear of the chassis. To learn how to remove the underlift, see Section 3.8.5 Removing the underlift from the wrecker.

NOTICE

Exercise caution when using the crane with the underlift, since any contact between the boom and underlift can damage the equipment.

3.3 Safety guidelines

Before operating the underlift, boom or winches, ensure that:

- You fully understand all the safety rules in Chapter 2 Safety.
- You are familiar with the wrecker and you have positioned it for optimal and safe operation (see Section 3.4 Familiarizing yourself with the equipment).
- The truck is properly levelled and stabilized (see Section 3.7.1 Stabilizing the wrecker using the jack legs).

NOTE: Before restarting the engine, pull the emergency stop button to put it in the Up position.

3.4 Familiarizing yourself with the equipment

Before using the equipment, open the control panels and examine the controls and their layout. The controls are proportional, which means that the further the control levers are moved, the more the control speed increases. Proportional controls allow you to use very slow speeds for greater precision and maximum control of the load.

After familiarizing yourself with the equipment, we recommend running the engine at low speed (600–850 rpm).

3.5 Emergency hydraulic bypass

If you have trouble with the control panel on the left-hand side, you can use the manual override control panel in the rearmost toolbox on the right-hand side of the wrecker. To use the hydraulic levers, remove the protective cover over the levers. Another manual override control panel is inside the boom base for the boom and winch levers.

The PTO must be engaged in order to use the emergency hydraulic bypass.

IMPORTANT: Never store any tools or other items inside the protective cover. The hydraulic levers move when their corresponding electronic levers are activated, and any tools or other items inside could restrict the movement of the levers.

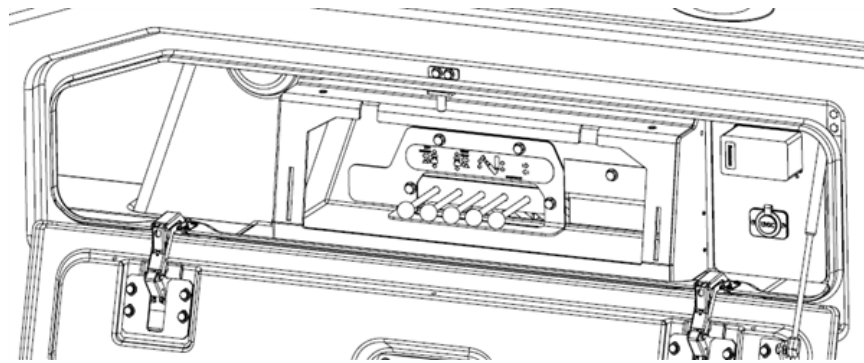

FIGURE 18 – EMERGENCY HYDRAULIC BYPASS CONTROL PANEL

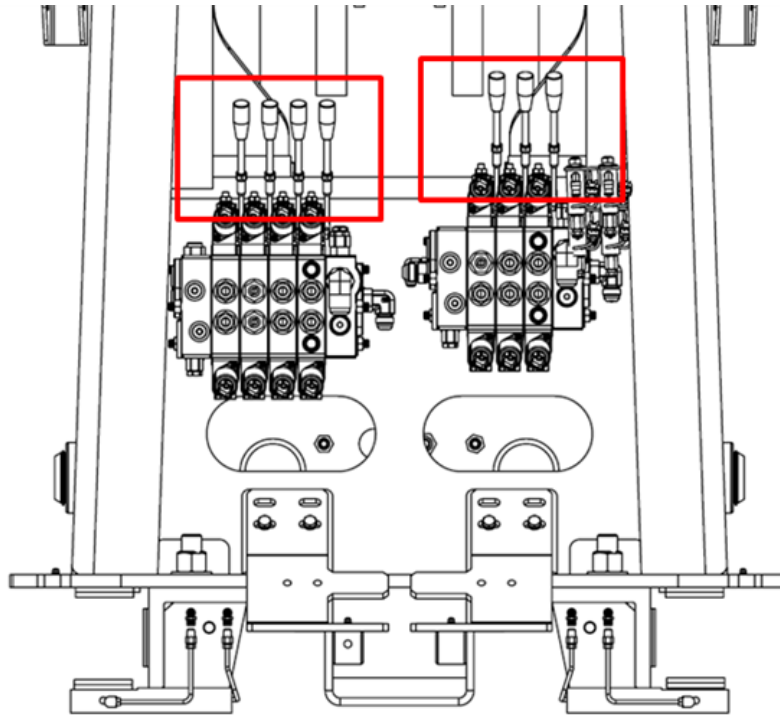

FIGURE 19 – EMERGENCY HYDRAULIC BYPASS IN THE BOOM BASE

3.6 Common operating procedures

This section explains procedures for starting the engine, arriving at the job site, and leaving the job site.

3.6.1 Engaging the power take-off

Engaging the power take-off (PTO) activates the hydraulic pump, which supplies power to the controls. When the PTO is engaged, a warning light in the cab warns you that driving the vehicle may result in damage. Before driving the wrecker, ensure that the warning light is off and the PTO is disengaged.

The following is a general procedure for a manual transmission. An automated transmission or fully automatic transmission might require a different sequence to engage properly. Refer to the transmission and PTO operation manuals specific to your vehicle.

WARNING

Turn off the wrecker engine and disengage the PTO when the wrecker is not in use.

DANGER

The area under the lifting unit is **DANGEROUS**. Stay as far away as possible from the danger zone while the machine is operating.

To engage the PTO:

1. Check that none of the emergency stop buttons have been pressed and pull them, if necessary.
2. Ensure that the PTO is disengaged.
3. Start the truck engine.
4. Ensure that air pressure is above 70 psi before engaging the PTO.
5. Press the clutch, engage the PTO and release the clutch to start the hydraulic system. The hydraulic system supplies power to the boom, underlift, winch, etc.

The control panels automatically turn ON when you engage the PTO.

3.6.2 Upon arrival at the job site

Before operating the wrecker on a job site:

1. Position the wrecker for optimal and safe operation (see Section 3.2 Preparing the wrecker for optimal performance).
2. Stabilize the wrecker (see Section 3.7.1 Stabilizing the wrecker using the jack legs).
3. Unhook the underlift from the boom (see Section 3.8.3 Unhooking the underlift from the boom) or remove the underlift from the wrecker body (see Section 3.8.5 Removing the underlift from the wrecker).

3.6.3 Before leaving the job site

After the job is finished, store the boom and underlift and prepare the wrecker for safe travel:

- Attach the underlift to the boom (see Section 3.8.4 Attaching the underlift to the boom).
- Lock the boom in travelling position (see Section 3.9.3 Locking the boom in travelling position).
- Lock the winches in storage position (see Section 3.10.5 Locking the winches in travelling position).

3.7 Using the jack legs

The following sections explain how to use the jack legs to stabilize your wrecker and how to store them after the job is finished.

You will need to stabilize the equipment to prevent the back suspension from getting stuck on the ground during lifting or winching and for providing a better ground grip.

3.7.1 Stabilizing the wrecker using the jack legs

Proceed as follows to stabilize your wrecker using the jack legs.

1. For more grip, install the recovery spades onto each jack leg. Lock them in place using the locking pin.

NOTE: The recovery spades are stored in toolboxes on each side of the equipment.

2. Go to the driver's side and lower the jack leg on this side to the ground, without jacking up the wrecker.

DANGER

Make sure you see the jack leg being lowered to ensure it does not hit any people or objects.

3. Go to the passenger side of the wrecker and use the control panel to lower the jack leg on this side, without jacking up the wrecker.
4. Lower both jack legs at the same time, just enough to get both rear wheels off the ground.

WARNING

Make sure that ONLY the jack leg feet touch the ground. If any other part of the jack leg touches the ground, it will compromise the stability of your wrecker. If this is the case, move the equipment to more level ground and try again.

3.7.2 Storing the jack legs

Once the job is complete, you need to store the jack legs in their travelling position as follows:

1. Using the levers on the driver's side, simultaneously raise both jack legs completely.
2. If you used recovery spades, remove the locking pin holding on each recovery spade. Remove the recovery spade and put the locking pin back in place. Store the recovery spades in the toolboxes located on each side of your wrecker.
3. Using the levers on the driver's side, fully retract both jack legs simultaneously.

3.8 Using the underlift

The underlift is used to tow another vehicle.

For safety purposes, the underlift must be hooked to the boom for transportation.

The following sections describe all underlift operations.

CAUTION

Do not drive the wrecker while the underlift is in the storage position (resting on the storage pin).

3.8.1 Understanding the underlift movements

The underlift is attached to and supported from above by the boom. The underlift also has two attached rollers, one on each side, that roll inside the rails of the wrecker. The rollers act as the underlift's fulcrum. Move the underlift and stinger by moving the boom as follows:

- Extend the boom to tilt the underlift stinger toward the ground. This will position the stinger under the vehicle to be towed.
- Retract the boom to tilt the underlift stinger away from the ground. This will lift the vehicle to be towed.
- Raise the boom to raise the whole underlift. This will raise the vehicle that you are towing.
- Lower the boom to lower the whole underlift. This will lower the vehicle that you are towing.

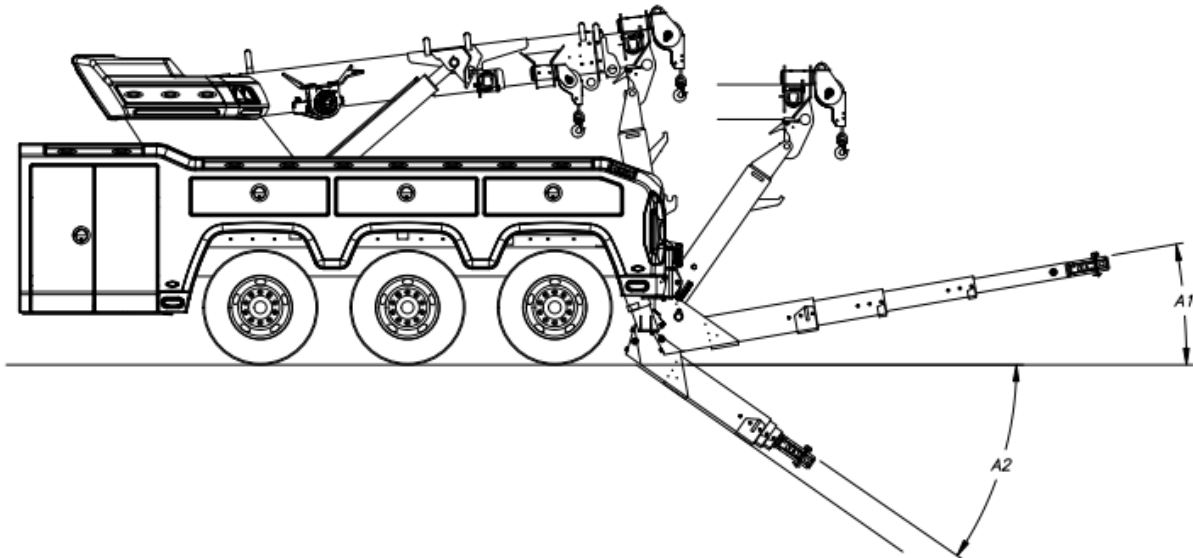

FIGURE 20 – UNDERLIFT MOVEMENTS

3.8.2 Towing another vehicle

⚠ CAUTION

If using the NRC Heavy duty tire lifts (bus brackets), use caution when installing them onto the T-bar to prevent injury. Position yourself correctly while lifting heavy objects.

⚠ DANGER

Always secure the disabled vehicle using wheel chocks before working around or under it.

When lifting a disabled vehicle using the underlift, always use jack stands or wheel stands to secure the vehicle and prevent it from falling before attempting any work under it. Failure to do so may lead to serious injury or even death.

1. Disengage all winches (see Section 3.10.2 Disengaging and engaging the winches).

NOTICE

This prevents damage to the winches and cables when extending the boom.

2. Extend the underlift stinger a few inches to allow it to clear its retaining clamp.
3. Unfold the underlift stinger completely using the corresponding lever on the control panel.
4. Lower the underlift, adjust the angle and extend the stinger using the corresponding controls to position the underlift beneath the vehicle to be towed.

NOTE: The boom is attached to the underlift, so they move together.

5. Choose a lifting point on the vehicle to be towed. It must be both strong enough and have enough clearance for the underlift stinger to move.

⚠ DANGER

Using a poor lifting point can cause severe damage to the towed vehicle and the wrecker, or even result in a serious accident.

6. If needed, back up the wrecker closer to the vehicle to be towed to enable the underlift stinger to reach the chosen lifting point.

NOTE: If your wrecker is equipped with a remote control, you can use it to operate the underlift stinger. Alternatively, use the control panel levers.

7. Select the towing accessories or tools compatible with the chosen lifting point and position them on the T-bar.
8. Position the towing accessories under the lifting points using the underlift extension control.

⚠ DANGER

Always use safety wheel stands when working under a towed vehicle. This will reduce the risk of a towed vehicle falling if the underlift system or its ancillary equipment fail. Failure to do so may lead to serious injury or even death.

9. Attach and secure the vehicle to be towed to the towing accessories.
10. Lift the vehicle to be towed. For clearance and a height that is safe and complies with regulations, adjust the underlift stinger to the desired height.
11. Fully retract the underlift stinger, leaving enough clearance for a 70-degree turn. The more you retract the stinger, the less weight is transferred from the front axle to the rear axle, increasing vehicle control and manoeuvrability.

NOTICE

Always leave enough clearance for a 70-degree turn. Failure to leave enough space may result in severe damage to the towed vehicle and the wrecker.

12. Disengage the winches (see Section 3.10.2 Disengaging and engaging the winches) and attach the cables to a suitable point on the underlift. Engage the winches and tighten the cable to prevent movement. Overtightening the cables can damage the cables, winches, boom or underlift.
13. Install the safety chains in the chain boxes on the rear bumper of the wrecker. Attach them to a solid anchor point on the vehicle to be towed to connect it to the T-bar and wrecker.
14. Prepare the vehicle to be towed.
 - a. Install the tow lights.
 - b. Connect the air supply and brake control. Test the brake.
 - c. Remove and secure the drive shaft(s) of any drive axles on the ground as per the recommendations from the towed vehicle manufacturer.

NOTE: For more detailed information on recovery and towing procedures for the vehicle to be towed, see the owner's manual of the vehicle to be towed.

The wrecker is now ready to tow the vehicle using the underlift. See Section 3.6.3 Before leaving the job site.

3.8.3 Unhooking the underlift from the boom

1. Disengage all winches (see Section 3.10.2 Disengaging and engaging the winches).

NOTICE

This will prevent damage to the winch cables.

2. Slowly lift the underlift with the boom, just enough for the storage pin to slide into the pin hole in the underlift (see Figure 21).

NOTE: Storage pins are normally located in the rear toolboxes.



FIGURE 21 – INSERTING THE UNDERLIFT STORAGE PIN (EXAMPLE)

3. Slide the storage pin into the pin hole.

4. If your wrecker is equipped with the **manual safety attachment**:
 - a. Unlock the underlift safety attachment on the boom.

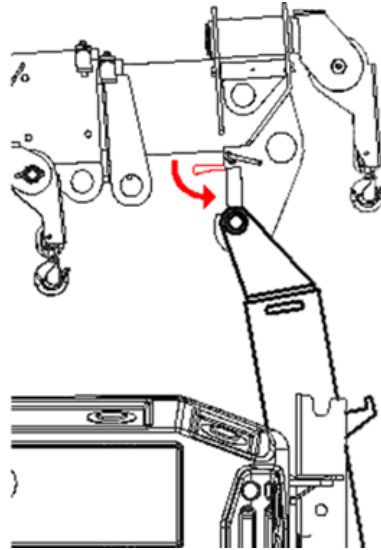

FIGURE 22 – UNLOCKING THE SAFETY ATTACHMENT (EXAMPLE)

- b. Slowly lower the boom so that the weight of the underlift is supported by the storage pin.

NOTICE

Ensure that the safety attachment is unlocked before lowering the boom. This prevents potential damage to the boom and underlift.

- c. Lower the boom just enough to allow the boom head hooks to pass under the hinge pin at the top of the underlift.
 - d. Extend the boom so that the underlift is completely detached and supported by the storage pin.

5. Or, if your wrecker is equipped with the **automatic safety attachment**:
 - a. Remove the underlift safety pin from the boom.

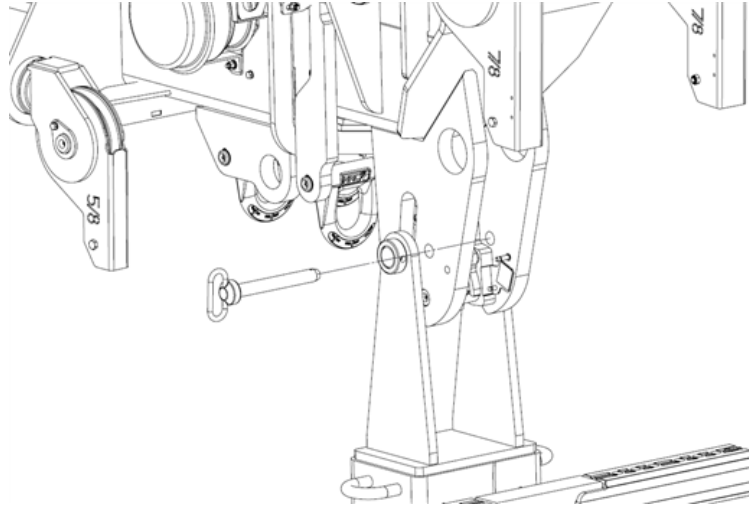

FIGURE 23 – REMOVING THE SAFETY PIN

- b. Slowly lower the boom until the automatic locking system unlocks (almost at the bottom of the underlift's slot).
 - c. Raise the boom.

The underlift is now unhooked and the boom is ready for use.

3.8.4 Attaching the underlift to the boom

1. If the boom base is not entirely in front of the wrecker, slide it all the way forward so that it is in the slider lock.
2. If your wrecker is equipped with the manual safety attachment, when the boom head hook is just below the storage pin in the top of the underlift, retract the boom until the safety attachment locks the boom to the underlift. If your wrecker is equipped with the automatic safety attachment, slowly lower the boom head hook onto the underlift until you hear the automatic safety attachment click. Install the safety pin.
3. Using the boom, slowly lift the underlift, just enough to allow the storage pin to slide out of the hole.
4. Slide the storage pin out and store it in the toolbox.

The underlift is now hooked to the boom.

3.8.5 Removing the underlift from the wrecker

1. Unhook the underlift from the boom (see Section 3.8.3 Unhooking the underlift from the boom).
2. Stop the hydraulic pumps by either turning off the truck engine or disengaging the PTO.
3. Disconnect the MultiFaster hydraulic coupler that connects the underlift to the body and place it in the docking bracket on the side of the underlift.



FIGURE 24 – PUT THE HYDRAULIC LINES IN THE DOCKING BRACKET (EXAMPLE)

4. Restart the engine or engage the PTO.
5. Lift and align the boom so that there are a few feet of space between it and the top of the underlift.

6. Gently unwind the main winch cables and attach the cables to the eyes near the top of the underlift.

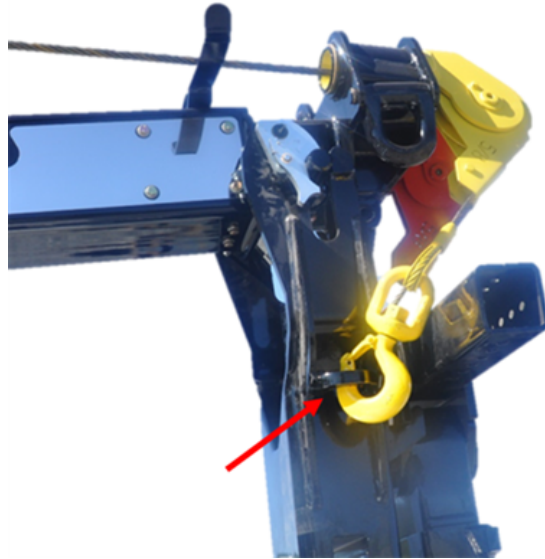

FIGURE 25 – ATTACHING THE CABLES TO THE EYES (EXAMPLE)

7. With the winches set to free spool, lift and extend the boom over the underlift. Position the boom so that there is enough clearance to fully lift the underlift and the wire ropes run straight up and down from the hook points.
8. Engage the winches and start lifting the underlift. Continue lifting until you start to see the underlift rollers.

⚠ WARNING

Stop lifting the underlift before the rollers leave their rails.

- Position the centre of gravity of the underlift by extending or retracting the boom until pressure is no longer exerted on the two roller guides in the underlift rails. Depending on your wrecker model, this pressure is generally relieved when the underlift forms a 25–30° vertical angle and the rollers are not touching the rails at the points indicated by arrows in the figure below.

NOTICE

To prevent the underlift from swinging when it is lifted out of the rails, find its centre of gravity. If the underlift swings too much, it could hit the vehicle.

⚠ DANGER

Never allow anyone near the wrecker when removing the underlift. The underlift may swing and hit someone when it is removed, resulting in serious injury or death.

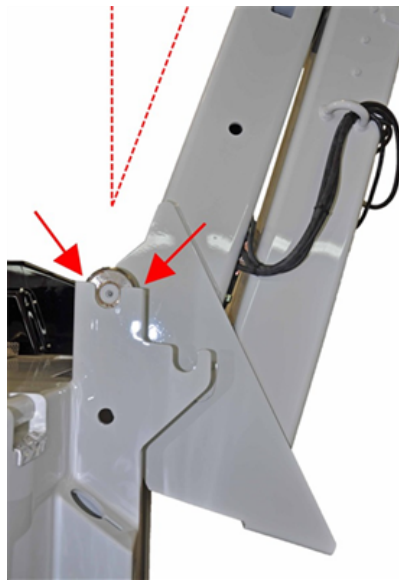

FIGURE 26 – POSITIONING THE UNDERLIFT IN THE RAILS (EXAMPLE)

- Raise the boom until the underlift clears the rails.

11. Move the boom to put the underlift down on a firm surface. It is recommended that you lay the underlift flat behind the truck. When you first put the underlift down vertically, leave enough space behind the truck to lay the underlift flat. By unwinding the winch cables and possibly retracting the boom, you can bring the underlift down completely. This is shown in the figure below.

⚠ DANGER

Never rest the underlift in a vertical position when it is not supported by the cables attached to the boom. An underlift is heavy and may fall. Always lay it flat on the ground.

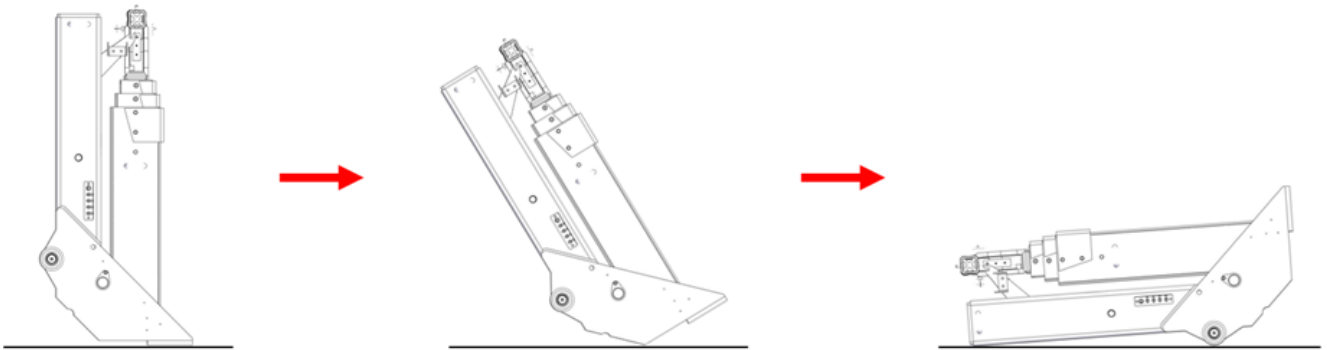

FIGURE 27 – PLACING THE UNDERLIFT ON A FLAT SURFACE (EXAMPLE)

12. Disconnect the two winch cables.

The boom is now ready for use.

3.8.6 Removing the tag axle from the wrecker

You can remove the tag axle from the wrecker in two ways:

- Remove the tag axle and the attached underlift at the same time. This is useful if you want to remove the tag axle and underlift from your wrecker and do not need the underlift.
- Remove the underlift from the tag axle, then remove the tag axle from the wrecker. This is useful if you need to reattach the underlift to the wrecker for jobs to be done with the underlift.

Removing the tag axle and the attached underlift at the same time

To remove the tag axle and the attached underlift at the same time:

1. Stop the hydraulic pumps by turning off the truck engine or disengaging the PTO.
2. Ensure that the underlift is resting on its storage pin.
3. Secure the underlift to the tag axle with its two locking pins.

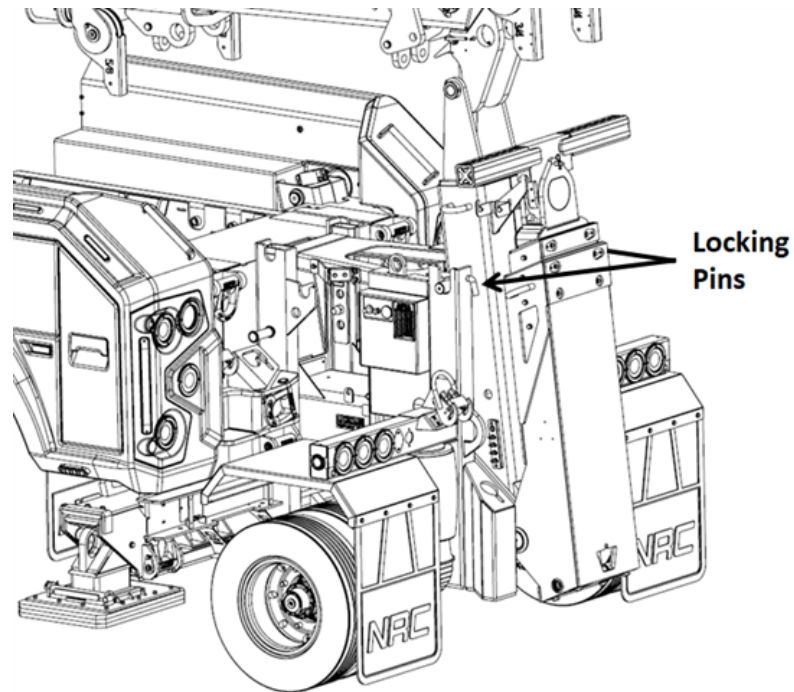

FIGURE 28 – SECURING THE UNDERLIFT TO THE TAG AXLE

4. Disconnect the MultiFaster hydraulic coupler that connects the underlift to the tag axle and place it in the docking bracket on the side of the underlift. Additionally, disconnect the electrical cable and three air hoses.



FIGURE 29 – PLACING THE CABLES AND HOSES IN THE DOCKING BRACKET (EXAMPLE)

5. Restart the engine or engage the PTO.
6. Slightly raise the boom to relieve the pressure on the pins securing the tag axle assembly to the wrecker tag axle rails. Remove the pins and store them.
7. Slightly extend or retract the boom so the tag axle's centre of gravity allows the tag axle to slide freely in the rails. Using the boom, lift the tag axle close to the end of the rails and ensure that it is still centred in the rails by slightly extending or retracting the boom.
8. Using the boom, slowly lift the tag axle out of the rails.

9. Once the tag axle is out of the rails, move the boom to put the tag axle down on a firm surface. Properly chock the tag axle's wheels to prevent the tag axle from moving. Place blocks under the tag axle and underlift so that the assembly stands securely upright and will not fall.

DANGER

Never leave the tag axle on the ground without chocks in front of and behind the wheels to prevent it from moving. Also, make sure to securely stabilize the assembly with blocks. The tag axle is heavy and may fall if not properly secured with blocks, which could cause serious injury or even death.

10. Unhook the underlift from the boom (see Section 3.8.3 Unhooking the underlift from the boom).

Removing the underlift from the tag axle, and then removing the tag axle from the wrecker

To remove the underlift from the tag axle, and then remove the tag axle from the wrecker:

1. Remove the underlift from the tag axle (see Section 3.8.5 Removing the underlift from the wrecker), but instead of disconnecting the underlift's MultiFaster hydraulic coupler from the body, disconnect it from the tag axle.
2. Disconnect the MultiFaster hydraulic coupler that connects the tag axle to the body and place it in the docking bracket on the side of the tag axle.
3. Restart the engine or engage the PTO.
4. Lift and align the boom so that there are a few feet of space between it and the top of the tag axle.
5. Gently unwind the main winch cables and attach the cables to the eyes near the top of the tag axle.
6. Slightly raise the boom to relieve the pressure on the pins securing the tag axle to the wrecker tag axle rails. Remove the pins and store them.
7. Slightly extend or retract the boom so the tag axle's centre of gravity allows the tag axle to slide freely in the rails. Using the boom, lift the tag axle close to the end of the rails and ensure that it is still centred in the rails by slightly extending or retracting the boom.
8. Using the boom, slowly lift the tag axle out of the rails.

9. Once the tag axle is out of the rails, move the boom to put the tag axle down on a firm surface. Properly chock the wheels of the tag axle to keep the tag axle from moving. Place blocks under the tag axle so that the tag axle stands securely upright and will not fall.

! DANGER

Never leave the tag axle on the ground without chocks in front of and behind the wheels to prevent it from moving. Also, make sure to securely stabilize the tag axle with blocks. The tag axle is heavy and may fall if not properly secured with blocks, which could cause serious injury or even death.

10. Disconnect the two winch cables.

3.8.7 Attaching the underlift to the wrecker

When the underlift has been removed, you must put it back on the wrecker before leaving the site.

1. Position the boom and the winch cable hooks so that you can attach the winch cable to the underlift.
2. Connect the two winch cables to the eyes near the top of the horizontal part of the underlift stinger.
3. Wind in the winch cables and, if needed, extend the boom to lift the underlift.
4. Raise the boom so the underlift is high enough to clear the underlift rails.
5. Lower the boom and align the underlift rollers with the rails. Continue lowering and possibly retracting the boom so the underlift goes into its rails.
6. Insert the storage pin in the pin hole in the underlift. Continue moving the underlift into its rails and stop when the underlift is supported on the storage pin.
7. Stop the hydraulic pumps by either turning off the truck engine or disengaging the PTO.
8. Reconnect the MultiFaster hydraulic coupler that connects the underlift to the wrecker (on the multi-coupler).
9. Restart the engine or engage the PTO.
10. Hook the underlift to the boom (see Section 3.8.4 Attaching the underlift to the boom).

3.9 Using the boom

The boom is normally used to lift a load or another vehicle for towing. The boom can be slid toward the front or rear of the vehicle, allowing you to lift a load. The position and weight of the load will determine which procedures in this section you will need to use.

! DANGER

Before operating the boom, make sure you understand the principles of operation (see Section 3.1 Operating principles) and follow the safety guidelines (see Section 3.3 Safety guidelines). Perform all the preliminary steps to ensure that the wrecker is stable and level (see Sections 3.4 Familiarizing yourself with the equipment and 3.7.1 Stabilizing the wrecker using the jack legs).

3.9.1 Preparing the slider

To allow the boom to move, you first need to unlock the slider using the control panel.

To unlock the slider, you may have to move the slider forward to relieve any pressure on the locks.

To move the boom forward or backward:

1. Ensure that both rails are well lubricated.

NOTE: Use Teflon grease to lubricate the rails (see Section 4.3 Lubrication).

2. Slide the boom base back and forth a few times over the entire stroke of the slider to spread the grease evenly.

3.9.2 Sliding the boom

1. Ensure that the slider is unlocked on the control panel.
2. Push the boom slider lever up or down to slide the boom forward or backward.

3.9.3 Locking the boom in travelling position

Once you have completed a towing job, lock the boom in its storage position.

1. Use the boom slider lever to slide the boom all the way forward.
2. Use the control panel to lock the slide and check that it is locked. Push the slider lever up and down to ensure that the locks are activated (the boom does not slide forward or backward) and the boom is safely stored.

3.10 Using the winch

The wrecker has up to five winches, which can be used for winching or for lifting a load or another vehicle.

You can operate the winches using the controls on either control panel or on the remote control. Use the controls that will provide the best visibility and enable you to work safely.

To operate the wrecker, you will need to engage one or more winches, depending on the load size and weight. You may also need to disengage the winches for operations such as extending the boom.

For heavy winching, always make sure the mast is locked into forward position by closing the slider doors.

DANGER

Before extending the boom, make sure the winch cables or synthetic ropes can move freely or are disengaged. Do not extend the boom if the hook is attached to the wrecker body. This could damage the cables, winches and sheave heads, and cause injury or even death.

IMPORTANT: This section provides general information on how to use the winches. NRC equipment uses winches of various brands and models. Always refer to the winch manufacturer manual for information specific to your winch.

3.10.1 Recommended break-in procedure

Before using your wrecker for the first time or installing new cables, we recommend fully unwinding the cables, leaving only five turns on the winch drum and making three complete pulls at approximately half the capacity. This will break in the cable fibres and extend the life of both the cable and the winch.

3.10.2 Disengaging and engaging the winches

Each winch has its own lever on the control panels and on the remote control.

Use the touchscreen interface or remote control button to disengage or engage a winch. Push the corresponding winch lever up and down several times to release the pressure on the clutch and fully disengage the winch.

NOTE: After engaging the winch, wait at least five seconds before using it to ensure that the air clutch is properly engaged.

DANGER

Never disengage a winch that is under load.

NOTICE

The 6,804 kg (15,000 lb.) Ramsey winches have a green light directly on the housing. This light turns on when the winch is properly engaged. Never operate the winch if the green light is not on.

3.10.3 Winding and unwinding the winch cable

Once a winch is properly engaged, push its control lever up or down to wind or unwind the cable.

You can increase the winding and unwinding speed of the main winch cable by activating the high-speed function on the touchscreen interface. This function also controls the boom rotation speed. Adjust the speed control function to operate at low speed when working under load.

CAUTION

For safer operation, it is recommended to never leave the equipment on the high speed option. Always put it back on low speed after each operation.

3.10.4 Resetting the winch control mechanism to zero

If the power is cut (by disengaging the PTO or pushing the emergency stop button), all the free spool clutches will be engaged for safety purposes. To use the winches again, reset the clutches to zero by flipping all four winch switches to the engaged position.

3.10.5 Locking the winches in travelling position

1. Engage each winch.
2. Wind the winch cable in fully.

NOTICE

Do not over-wind the cable and cause the hook to exert tension on the pulley. This could result in severe damage.

3.11 Using the remote control with control levers

Your wrecker may be equipped with a remote control that has control levers. The remote control is used to control the wrecker from afar, where you can remain at a safe distance from the load and more easily see what you are doing while operating the controls.

3.11.1 Preparing the remote control

To prepare for using the remote control:

1. Put the remote control somewhere comfortable, such as on a belt around your waist or neck. Wearing it on your waist will allow you to move the remote control to your back, which will protect it while you perform various tasks.
2. Turn the remote control on. If it is turned off when the option to control the wrecker with the remote control is selected, the truck will turn off.
3. On the touchscreen interface, select the option to control the wrecker with the remote control.
4. Ensure that the remote control emergency stop button is pulled out.
5. Turn the key clockwise to turn on the remote control.
6. Push the green button beside the key to verify that the wrecker is receiving the remote control signal. The wrecker will make a sound to confirm that it is receiving the signal. The green light in the middle of the remote control will blink. If the green light does not blink, the remote control battery may be faulty or you may be too far away from the wrecker.
7. Ensure that the remote control emergency stop button is pulled out.

3.11.2 Preparing the wrecker for use with the remote control

IMPORTANT: Prepare the remote control before preparing the wrecker for remote control operation, or the truck will shut off.

To prepare the wrecker for remote control operation, use the control panel on the driver's side.

1. Flip the remote control switch to the remote control position. The red light on the switch will illuminate, meaning that the remote control receiver is on and that the levers on the control panel are disabled.
2. Engage all the winches by flipping the four winch switches down. The red light on each switch will turn off, allowing you to disengage and engage the winches using the remote control.
3. Set the speed control switch to slow. The red light on the switch will turn off, allowing you to control the speed using the remote control.

3.11.3 Operating the wrecker with the remote control

To operate the wrecker using the remote control:

- To turn the wrecker engine on or off, use the two buttons on the side of the remote control.
- To disengage a winch, push and hold the corresponding winch button. Release the button to engage the winch.
- To rotate the boom and wind and unwind the winch cable at high speed, toggle the speed switch to the high position. Toggle the speed switch to the low position to return to slow speed.
- You can perform all other functions using the remote control levers as you would with the control panel.

3.12 Using the remote control that has 6, 10 or 16 function buttons

This type of remote control is used to control the vehicle as you do with the control panel, but allows you to move around to better see what you are doing and to be in a safer place while you operate the wrecker.

3.12.1 Pairing the remote control with the receiver

To pair the remote control with the receiver, proceed as follows:

1. Turn the ignition key OFF or disconnect the power to the receiver.
2. Turn the ignition key ON or reconnect the power to the receiver. This opens a 20-second window in the receiver processor. If you are looking at the receiver's printed circuit board, which is located on the front panel of the wrecker body, you will see the fault LED flashing.
3. During these 20 seconds, press and hold the remote control Reset button for five seconds. When the transmitter and remote control are paired, the fault LED is illuminated continuously.

3.12.2 Operating the remote control

1. Push and hold the green button on the remote control.
2. Start using the remote control. Note that each remote control is built and programmed according to your requirements.

4 MAINTENANCE

Regular maintenance can prevent problems and damage to equipment. This chapter contains safety guidelines, maintenance procedures and the recommended maintenance schedule for your wrecker.

NOTE: See the winch manufacturer manual for more details about winch maintenance.

4.1 Safety guidelines

When performing maintenance on your wrecker, underlift, boom or winches, always:

- Ensure that you fully understand all the safety rules described in Chapter 2 Safety.
- Wear protective clothing (goggles, gloves, footwear, etc.)
- Watch out for moving parts.
- Watch out for hot components.
- When working under the vehicle, apply the parking brake and use wheel chocks.
- When lifting the vehicle, use approved and certified equipment that is in good condition.
- When performing overhead work, use rated jack stands and proceed with caution.

For winch safety guidelines, see the winch manufacturer manual.

4.2 General maintenance

NOTE: Remember that regular maintenance will keep your wrecker in good condition, extend its lifespan and reduce the risk of damage and breakage.

4.2.1 General wrecker maintenance

Description	After		Every					
	1st use	1 mth	1 day	2 wks	1 mth	3 mths	6 mths	1 yr
Adjust the hydraulic pressure. See Section 4.4.1 Adjusting the hydraulic pressure (main relief).						X		
Check the cable tensioner for all winches. See Section 4.2.4 Winch cable tensioner. Check the dial on the right side of the wrecker. The dial should indicate a pressure of approximately 75 to 90 psi (5.2 to 6.2 bar) to maintain the correct cable pressure.						X		
Inspect the bolts on the chassis mounting plates for damage and make sure they are tight. Have an NRC-authorized distributor inspect the chassis mounting plates for cracks or structural damage. See Section 4.2.2 Mounting plates maintenance.	X				X			
Replace all the oil filters (pressure and return filters). Clean the inlet filters and test the hydraulic fluid.		X						X

Description	After		Every					
	1st use	1 mth	1 day	2 wks	1 mth	3 mths	6 mths	1 yr
Inspect the equipment to ensure that it is in good condition for the next job.			X					
Lubricate the two bolts that hold the emergency hydraulic bypass cover in place.							X	
Lubricate the two pins on the MultiFaster.					X			
Check that no cylinders or hoses are leaking.			X					
Inspect all anchors, eyes and pulleys for cracks and structural damage.			X					
Verify that the slider rails are properly lubricated.			X					
Check that all the high-pressure indicators are green. If the indicators are red, replace the filter. The indicators are located directly on the filter.				X				
Verify the condition of the high pressure oil filter. If the indicator is red, replace the high pressure filter.							X	

4.2.2 Mounting plates maintenance

NRC recommends that wrecker mounting plates be inspected **every month** by trained and qualified personnel, and annually by an authorized NRC distributor. Should a visual inspection identify any cracks or structural damage, immediately discontinue use until the equipment is deemed safe.

After the first use and every month, inspect the bolts on the chassis mounting plates for damage and make sure they are tight.

4.2.3 Winch maintenance

See the winch manufacturer manual.

4.2.4 Winch cable tensioner

Check all the indicators for the cable tensioner for all winches. To maintain adequate tension on the cable, it should read approximately 72 psi. Adjust the pneumatic pressure using the integrated regulator when necessary.

4.2.5 Steel cables maintenance

Steel cables must be regularly inspected to ensure safe operation. When a cable is degraded, deformed or bent, you must replace it. See the ISO 4309:2017 standard for the criteria for inspection, maintenance and disposal of steel cables.

The cable dimensions vary based on the winch model. Figure 30 below illustrates the location of winches equipped with steel cables on each wrecker model. For equipment sold in North America, the table below shows the cables used for each winch model.

IMPORTANT: NRC only supplies steel cables for equipment sold in North America (NRC does not supply steel cables where Standard 14492 is applicable). When NRC does not supply the winch cable, the distributor must select the appropriate cable for their winch model.

TABLE 15 – STEEL CABLES FOR THE DIFFERENT WINCH MODELS (NORTH AMERICA ONLY)

Description	Wrecker model	Winch location	Length (ft.)	Cable specification
Steel cable for Ramsey RPH 30000 winch	30CS	Main	200	16 mm (5/8'') 6x36 (WS) EIPS 1960 IWRC
Steel cable for DP 40000 winch	40CS	Main	200	19 mm (3/4'') 6x36 (WS) EIPS 1960 IWRC
Steel cable for Ramsey RPH 15000 winch	40CS	Auxiliary	200	14 mm (9/16'') 6x36 (WS) EIPS 1960 IWRC
Steel cable for DP 50000 winch	50CS	Main	200	22 mm (7/8'') 6x36 (WS) EIPS 1960 IWRC
Steel cable for DP 20000 winch	50CS	Auxiliary	200	16 mm (5/8'') 6x36 (WS) EIPS 1960 IWRC
Steel cable for DP 50000 winch	40CS and 50CS	Drag	360	19 mm (3/4'') 6x36 (WS) EIPS 1960 IWRC

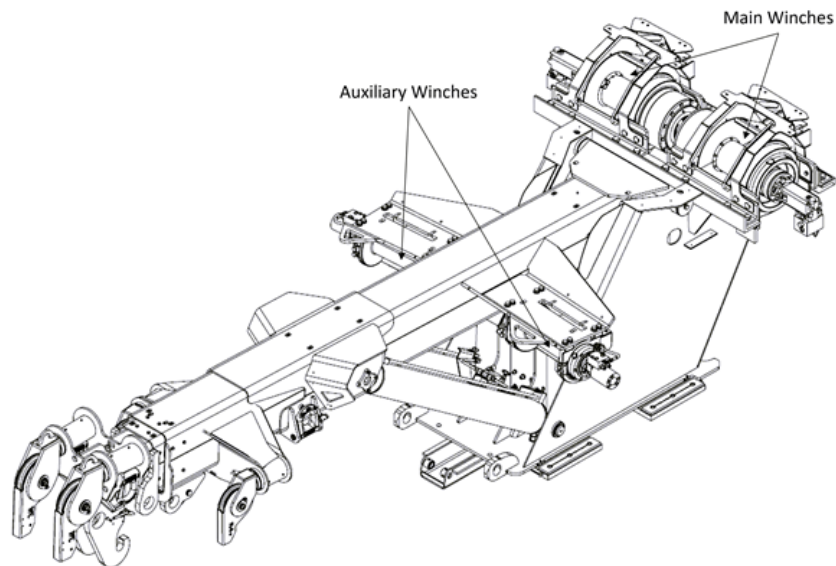

FIGURE 30 - WINCH LOCATIONS

4.2.6 Wear pads maintenance

Wear pads must be replaced according to the replacement frequency and other information shown in Table 16. Make sure to recycle or dispose of the worn wear pads in accordance with local legislation.

Log in to the NRC service website to locate part numbers and order wear pads:
<http://services.nrc-industries.com/>.

TABLE 16 - WEAR PADS

Description	Quantity	Replacement Frequency	Location
Underlift wear pads	3-section underlift: 4 3-section underlift Euro: 8 4-section underlift: 12	Before the thickness of the nylatron reaches the fixing bolt	On the tube of the different sections. See Figure 31.
Boom wear pads	2-section boom : 8 3-section boom : 16	When the thickness of the nylatron reaches the fixing bolt or anchor	On the tube of the different sections. See Figure 31.
Slider wear pads	12	When the thickness of the nylatron reaches the anchor of the wear pads	On the lower part of the slider. See Figure 31.

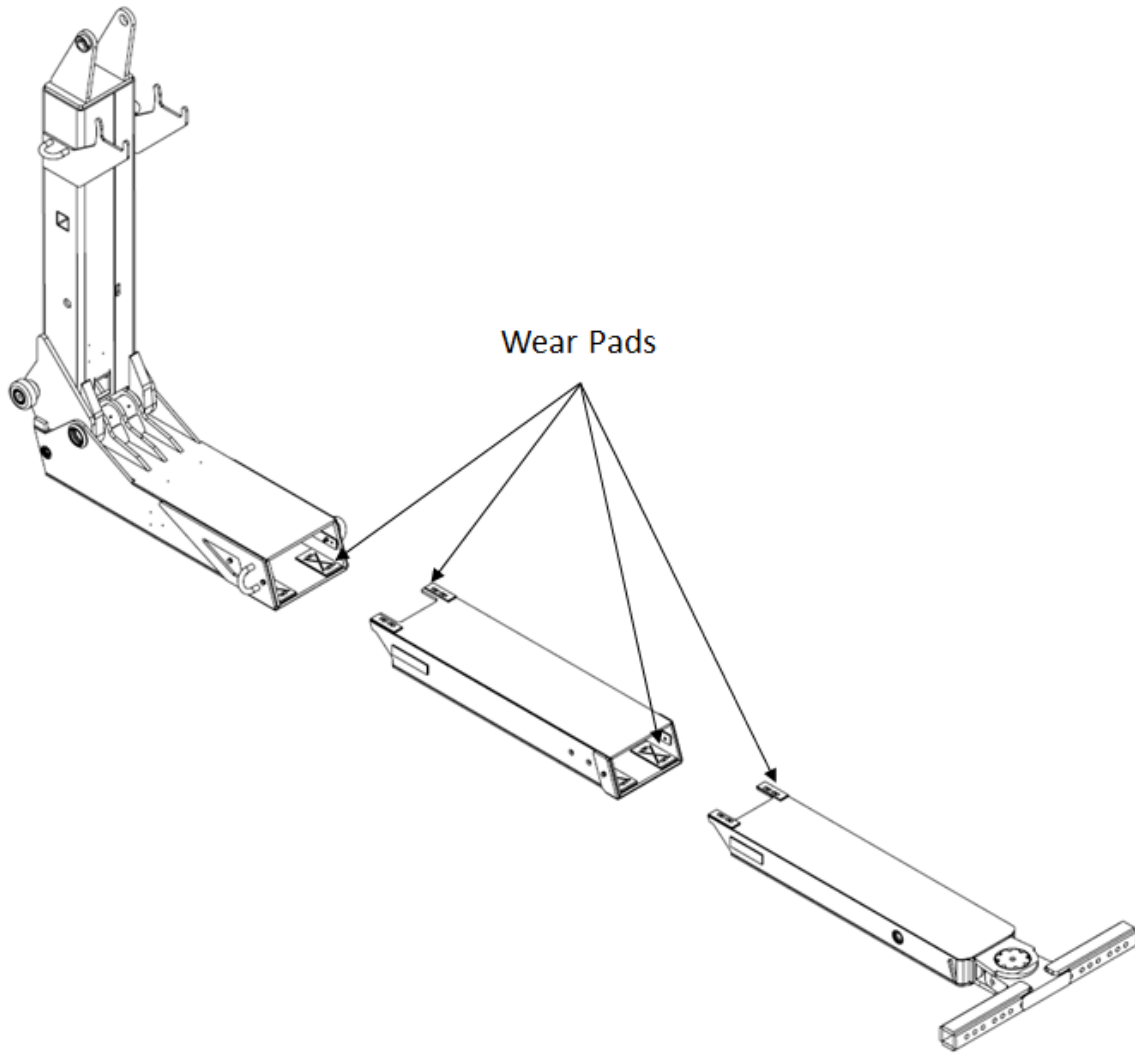

FIGURE 31 - WEAR PADS - UNDERLIFT

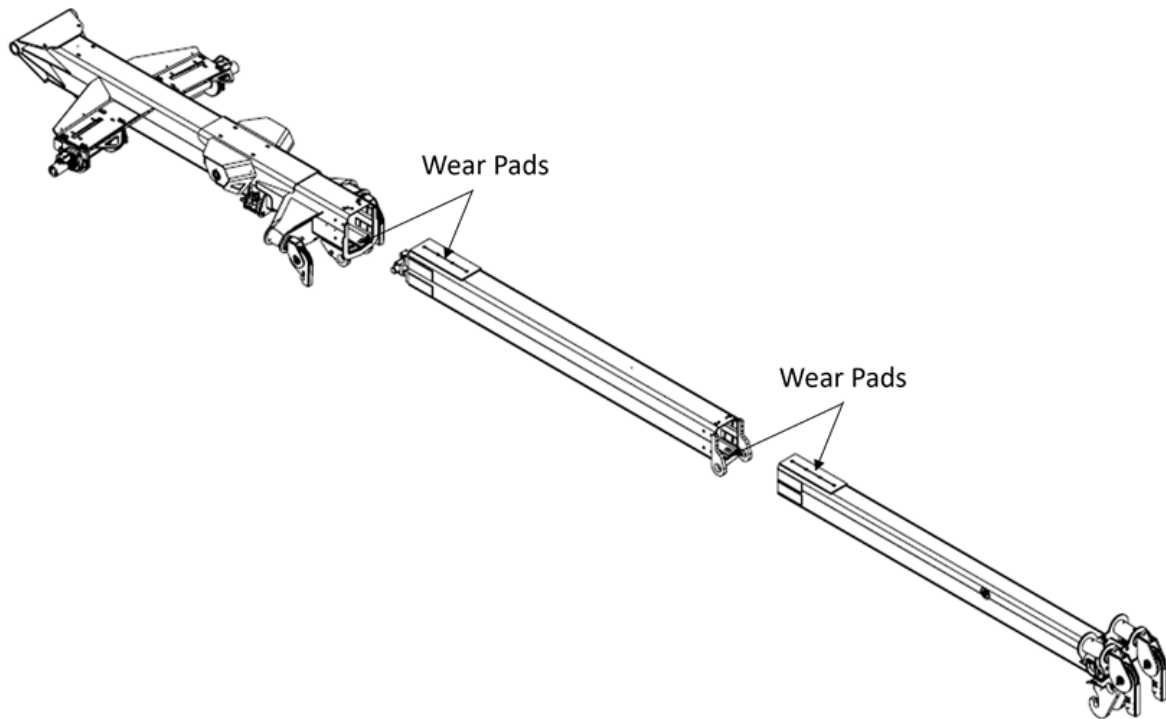

FIGURE 32 - WEAR PADS - BOOM

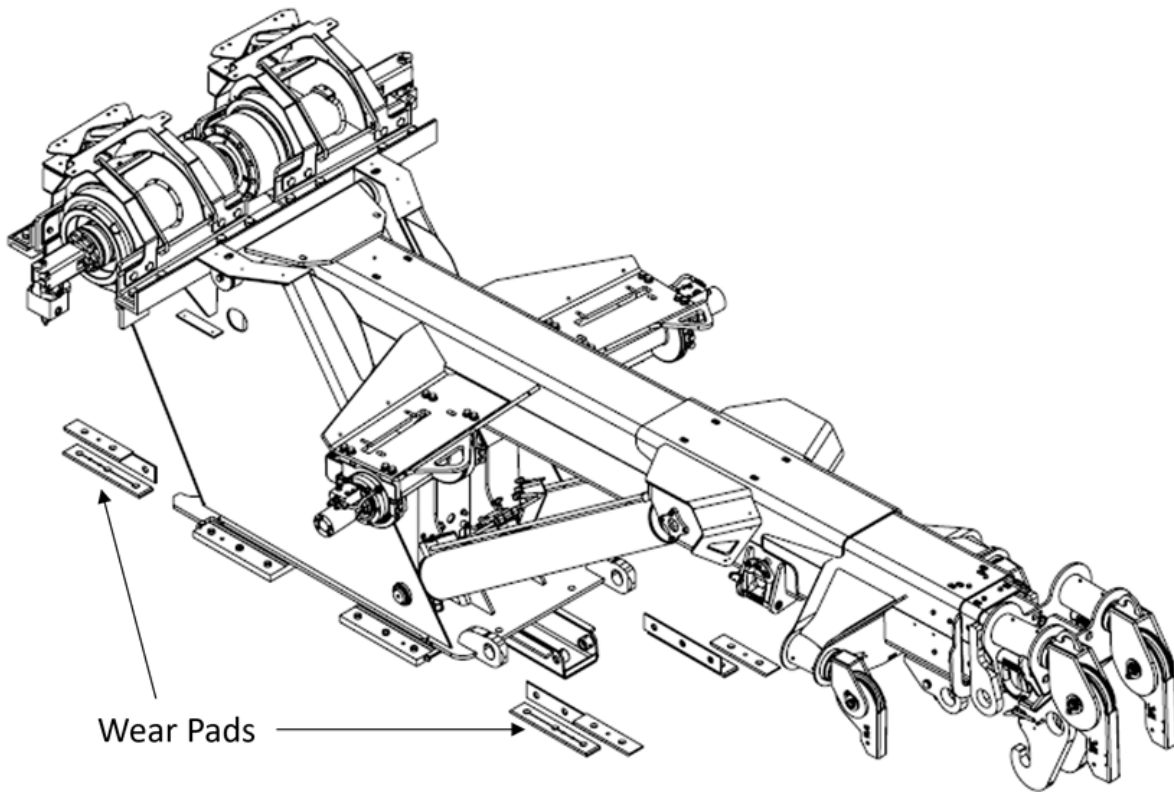

FIGURE 33 - WEAR PADS - SLIDERS

4.3 Lubrication

This section details the lubrication points and schedule for the various parts of your wrecker. Make sure to use the oil recommended by the manufacturer of each component.

4.3.1 Oil

IMPORTANT: NRC wreckers use oil for the hydraulic system and winches. When changing the oil, take care not to spill any. Collect the oil in a leak-proof can or container and bring it to your nearest collection point for recycling.

NOTE: Oil types for other equipment included with NRC equipment (e.g. winch) are provided for reference only. See the manufacturer's manual (e.g. winch manufacturer's manual) for the appropriate oil type and frequency for your application and model.

TABLE 17 – OIL TYPES AND LOCATIONS

Description	Quantity	Oil type or Commercial name	Frequency	Location
Oil for the Ramsey HD-P 30000 winch	Fill to the level indicated on the winch	SAE 75W-90. See the winch manufacturer’s manual	Every week. Add oil if needed. Replace oil at least every year or more frequently depending on usage.	Winch oil tank. See Section 4.2.5 for the location of the winch.
Oil for the ramsey RPH 15000 winch*	N/A	N/A	N/A	N/A
Oil for the DP 20 000, 40 000 and 50 000 winches	Fill to the level indicated on the winch	80W90 or 85W140 depending on the operating temperature. See the winch manufacturer’s manual	After the first 10 hours of operation. Then annually or at every 250 hours of operation.	Winch oil tank. See Section 4.2.5 for the location of the winch.
Oil for the winch cables	Along the full length of the cables, as required by the cable manufacturer	Lubricant for steel cables	4 to 6 months	All winch cables

*The RPH 15000 winch does not need additional oil.

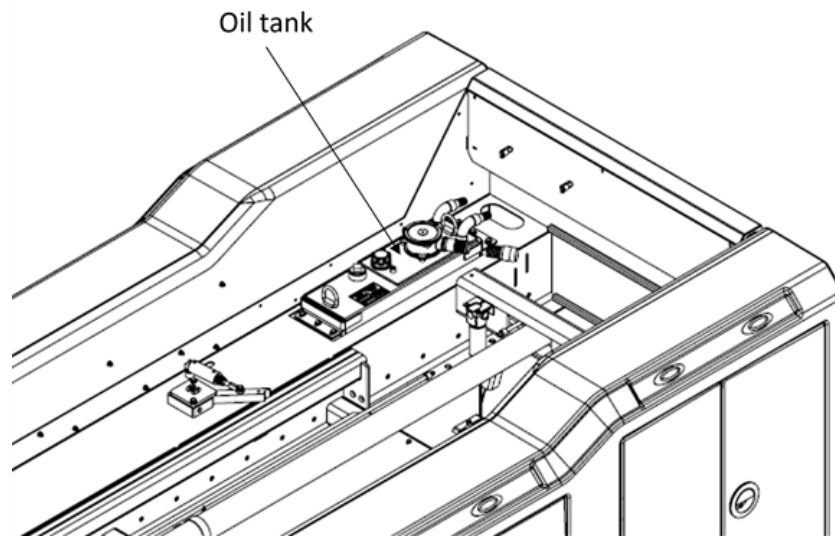

FIGURE 34 - OIL TANK - 30CS, 40CS AND 50CS

4.3.2 Oil filter cartridges

NRC wreckers include high-pressure filters and return filters. The cartridges for these filters must be replaced according to the schedule shown in the table below. The cartridge model and locations depend on the wrecker model. Contact your NRC distributor for the cartridge model number that applies to your wrecker model.

TABLE 18 – OIL FILTERS FOR THE 30CS, 40CS AND 50CS

Description	Quantity	Commercial name	Replacement frequency	Location
High-pressure filter	2	MP Filtri high-pressure filter	Annually	To access the high-pressure filter, move the boom back. See Figure 35.
Return filter	1	MP Filtri MPF return filter	After the first 6 months, then annually	On the oil tank. See Figure 35.

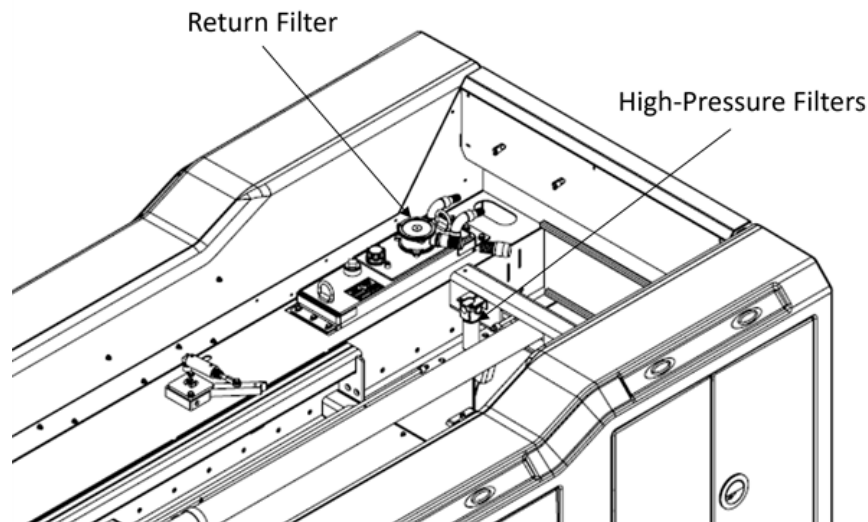

FIGURE 35 - FILTERS - 30CS, 40CS AND 50CS

4.3.3 Grease

See Table 19 for the lubricant type and frequency for each component. See Table 20 to Table 26 for the lubrication point locations of each components.

NOTE: The number of grease fittings may vary depending on the models of your wrecker components. For all grease fittings (zerks), look for the lubrication stickers located just beside each grease fitting.

TABLE 19 - GREASE SCHEDULE

Description	Lubricant type	After	Every			
		6 mths	1 wk	1 mth	3 mths	1 yr
Underlift grease fittings	Waterproof grease		X			
Underlift sliding surfaces	Waterproof grease			X		
All other grease fittings	Waterproof grease			X		
Boom sliding surfaces and jack legs	Waterproof grease				X	
Winch grease fittings	Waterproof grease	X				X
All valves	Antifreeze white grease					X
Slider tube	Teflon grease		X			

TABLE 20 - LUBRICATION POINTS - UNDERLIFT

NOTE: The number of grease fittings may vary depending on your underlift model.

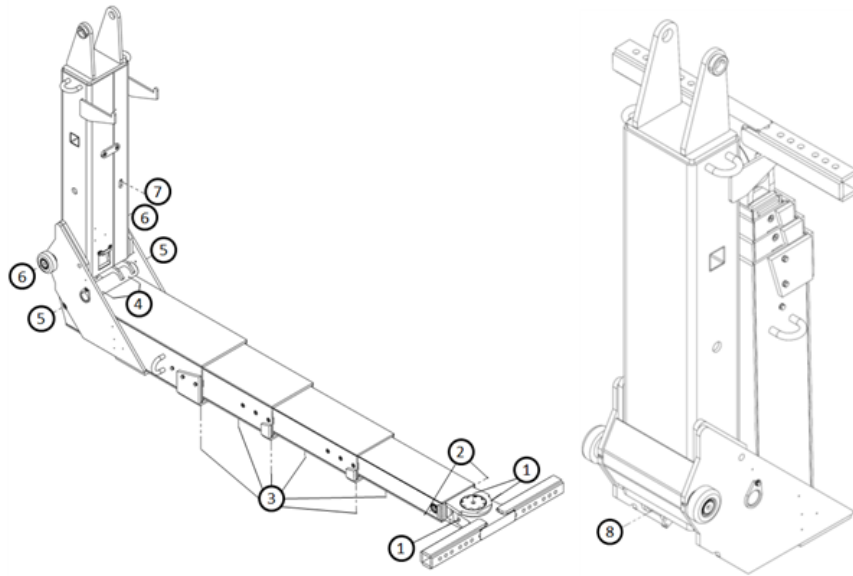

#	Lubrication point	Type
1	T-bar pivot	Grease fitting
2	Extension cylinder anchor point	Grease fitting
3	Sliding surfaces of each extension (Note 1)	Surface
4	Fold pivot	Grease fitting
5	Extension cylinder anchor point	Grease fitting
6	Underlift roller	Grease fitting
7	Fold cylinder anchor point	Grease fitting
8	Fold cylinder anchor point (Note 2)	Grease fitting

Note 1: Fully extend the underlift to access all sliding surfaces.

Note 2: Completely fold the underlift to access the grease fitting.

**TABLE 21 – LUBRICATION POINTS - BODY AND JACK LEGS
(CENTRALIZED GREASING POINTS OPTION)**

NOTE: The number of grease fittings may vary depending on your CS model. The figure below shows the right side of the wrecker (slider). The same lubrication points are also present on the left side.

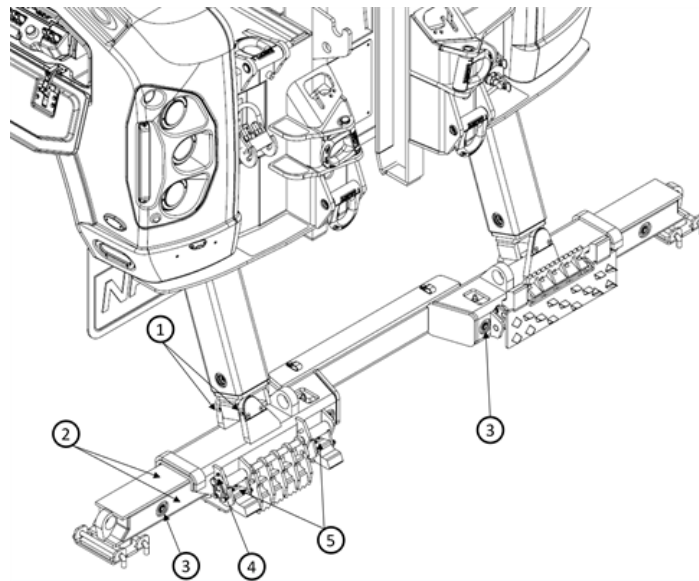

#	Lubrication point	Type
1	Outrigger leg anchor point	Grease fitting
2	Sliding surfaces of each extension	Surface
3	Extension cylinder anchor point	Grease fitting
4	Recovery spade plunger lock	Grease fitting
5	Recovery spade	Grease fitting

Note 1: Fully extend the jack legs. Lubricate each sliding surface (top, sides and bottom). Move the jack legs in and out several times to spread the grease evenly on all surfaces. Regularly and thoroughly grease the outriggers so their surfaces are always lubricated and protected against corrosion.

TABLE 22 – LUBRICATION POINTS - WRECKER

Name (number of lubrication points)	Type	Location / Note
Mechanism	Moving parts	Put spray grease on all moving parts to ensure that they can move freely.

TABLE 23 – LUBRICATION POINTS - WINCHES

Lubrication point	Note
All lubrication points	See the manufacturer's manual for the appropriate grease type and frequency for your application and model.

TABLE 24 – LUBRICATION POINTS - BOOM EXTENSION CYLINDERS

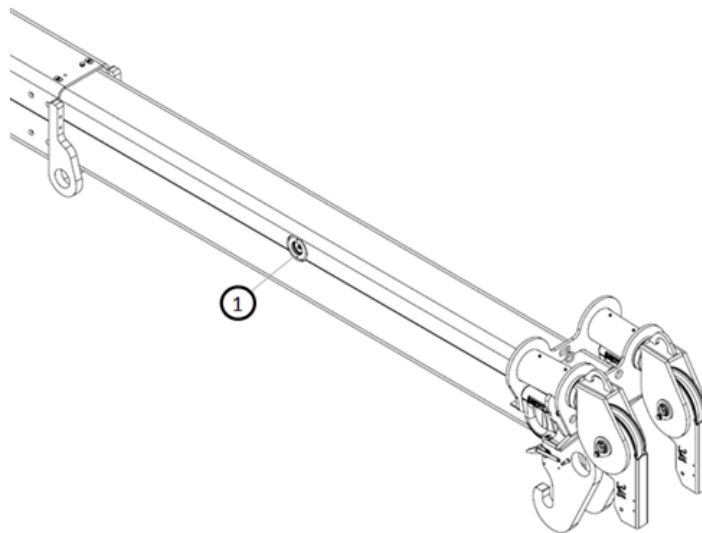

NOTE: The number of grease fittings may vary depending on your boom model.

#	Lubrication point	Type
1	Boom extension cylinder anchor point (2 per section)	Grease fitting

TABLE 25 – LUBRICATION POINTS - BOOM

NOTE: The number of grease fittings may vary depending on your boom model.

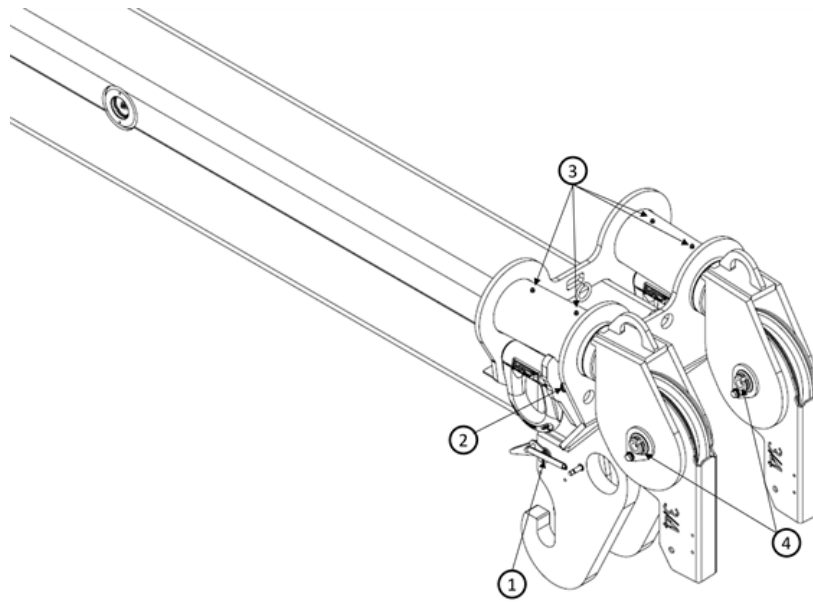

#	Lubrication point	Type
1	Underlift locking system (Note 1)	Grease fitting
2	D-ring	Grease fitting
3	Pulley bushing	Grease fitting
4	Main winch rotation	Grease fitting

Note 1: Extend the boom to access the fittings.

TABLE 26 - LUBRICATION POINTS - BOOM AND SLIDER BASE

NOTE: The number of grease fittings may vary depending on your wrecker model.

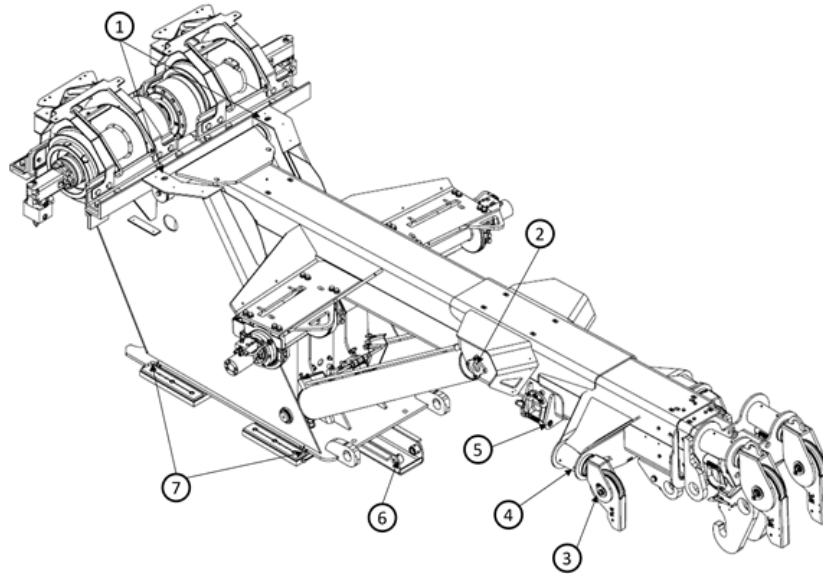

#	Lubrication point	Type
1	Boom rotation axis	Grease fitting
2	Lift cylinder anchor point	Grease fitting
3	Auxiliary winch rotation	Grease fitting
4	Pulley bushing	Grease fitting
5	D-ring	Grease fitting
6	Slider cylinder anchor point	Grease fitting
7	Slider top pad	Grease fitting

4.4 Maintenance procedures

This section presents all maintenance procedures.

4.4.1 Adjusting the hydraulic pressure (main relief)

The CS models have a dual inline hydraulic system that has three valves: two located in the boom base behind the steel cover, and one inside the wrecker body under the wrecker floor. As a result, the available hydraulic pressure will be limited by the element that provides the least pressure.

For each hydraulic valve, the pressure must be adjusted to 3,000 psi (206.8 bar). To adjust the pressure of each hydraulic system, first increase the pressure of each relief valve to 3,100 psi and then slowly decrease the pressure of each valve to 3,000 psi.

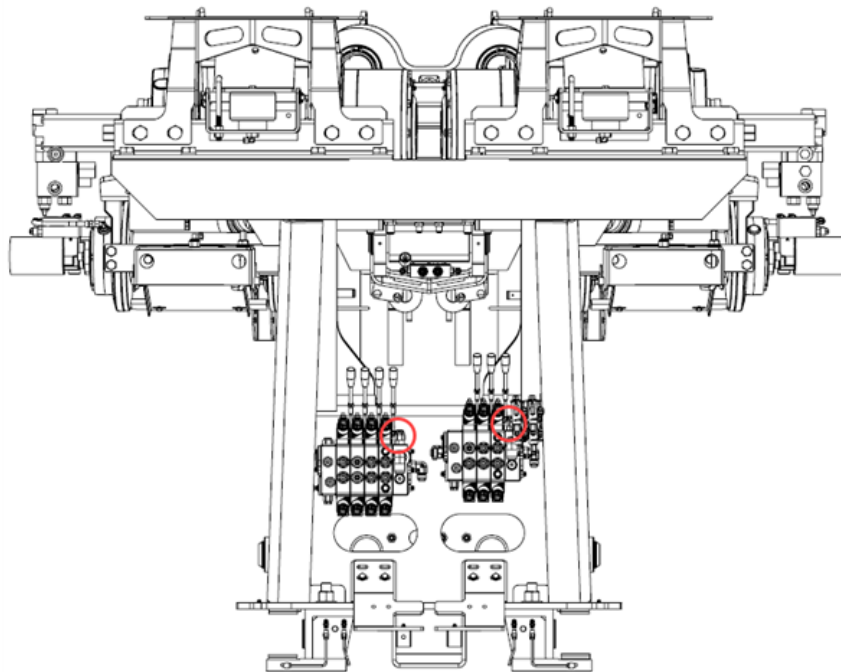

FIGURE 36 – POSITION OF THE RELIEF VALVES ADJUSTING SCREWS IN THE BOOM BASE

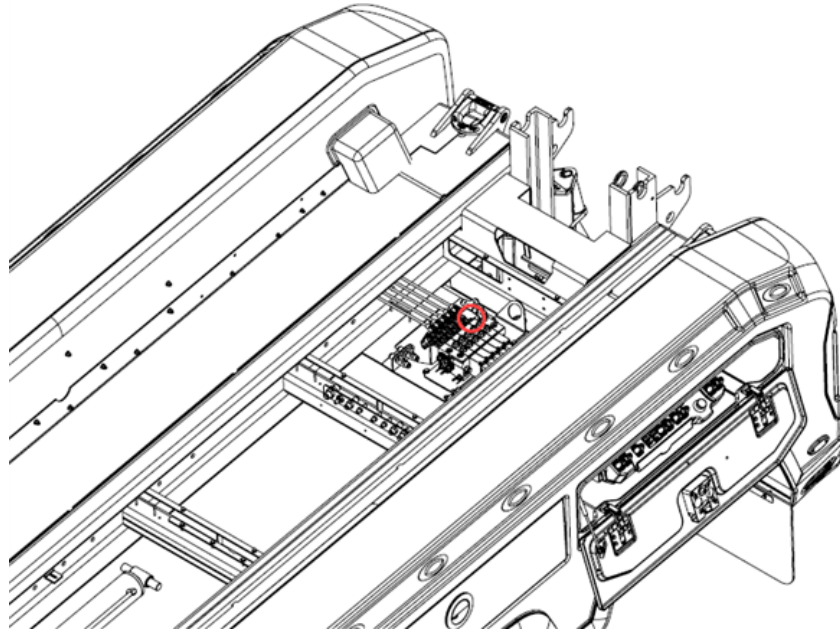

FIGURE 37 – POSITION OF THE RELIEF VALVE ADJUSTING SCREW UNDER THE WRECKER FLOOR

To check the hydraulic pressure of the hydraulic system:

The pressure has to be adjusted to 3,000 psi (206.8 bar) on each hydraulic valve.

1. Start the engine and set the engine speed to between 600 and 850 rpm.

NOTE: This is required to obtain an accurate pressure reading.

2. Engage the PTO.
3. Operate the lever that moves the right jack leg up (when the jack leg is already all the way up) and check that the pressure reads 3,000 psi on the gauge.

If the pressure is not at the appropriate setting (indicated above), you need to adjust the hydraulic pressure of the system as follows:

NOTICE

Do not turn the adjusting screw of the relief valve while operating a hydraulic control, as this may permanently damage the valve.

1. Set the hydraulic pressure to 3,100 psi. To do so :
 - a. Slightly loosen the locknut on each relief valve and turn the adjusting screw on each relief valve two turns to increase the pressure.
 - b. Re-test the hydraulic pressure as described above and check that it reads approximately 3,100 psi. If you cannot reach this value by adjusting the relief valves, the pump pressure is not high enough. In that case, you need to increase the pump pressure to 3,100 psi before proceeding with adjusting the relief valves.

NOTE: The pumps are located underneath the truck, near the transmission.

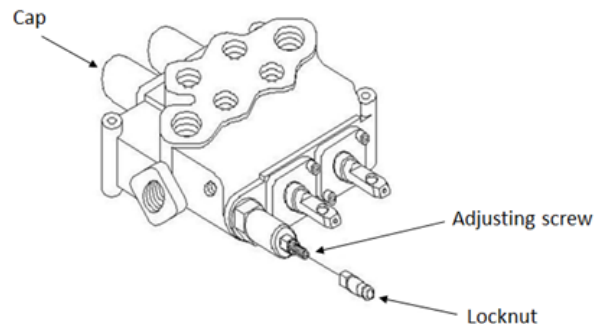

FIGURE 38 – ADJUSTING THE HYDRAULIC PRESSURE (MAIN RELIEF)

2. On one relief valve, start by loosening the relief valve locknut and then unscrew the adjusting screw no more than $\frac{1}{4}$ turn at a time until it reaches 3,000 psi. Re-test the hydraulic pressure after each $\frac{1}{4}$ turn to ensure that the pressure does not drop below the specified value. When the pressure reads 3,000 psi, this means that this relief valve is set to that value, and the others are set to a value above that.

3. On the other valves, one at a time, start by loosening the relief valve locknut and then unscrew the adjusting screw no more than $\frac{1}{4}$ turn at a time to decrease the hydraulic pressure until it drops below the intended value (e.g. 2,900 psi). Then, screw the adjusting screw back up again until you reach 3,000 psi. Repeat this process for all relief valves. At this point, all the valves will be set to the correct pressure.
4. Tighten all locknuts.

4.4.2 Adjusting the counterbalance valves (CBCG-LJN)

The wrecker has four counterbalance valves, which are all adjusted with the same adjustment: Completely screw and then unscrew $3 \frac{3}{4}$ turns.

- One is used to control the pressure of the boom in/out cylinder. It is located inside the boom.
- One is used to control the pressure of the boom up/down cylinders. It is located between the two cylinders.
- Two are used to control the pressure of each jack legs up/down cylinder. They are located behind the rear bumper.

NOTICE

Do not turn the adjusting screw of the relief valve while operating a hydraulic control, as this may permanently damage the valve.

1. Loosen the jam nut.

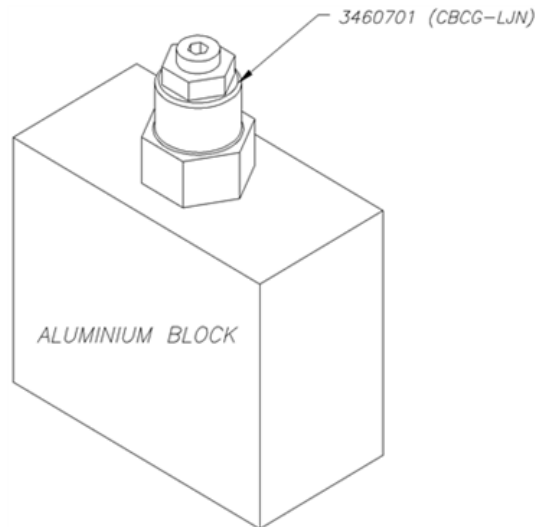

FIGURE 39 – ADJUSTING THE COUNTERBALANCE VALVE (CBCG-LJN)

2. Turn the set screw counter-clockwise until it stops.
3. Turn the set screw clockwise to the appropriate setting (described above) and keep the screw in this position while you tighten the jam nut.

NOTE: Position the Allen key so you can easily count how many turns you make when setting the screw.

4.4.3 Adjusting the underlift cushioning valve

The underlift cushioning valve is located inside the top rear section of the frame, under the aluminium cover. Should you have problems folding or unfolding the underlift, you may have to adjust the valve. The **B+A** cartridge controls the folding, and the **C+D** cartridge controls the unfolding. Both cartridges need to be set to 2,000 psi (138 bar). Ensure that the hoses are as shown in the following figure.

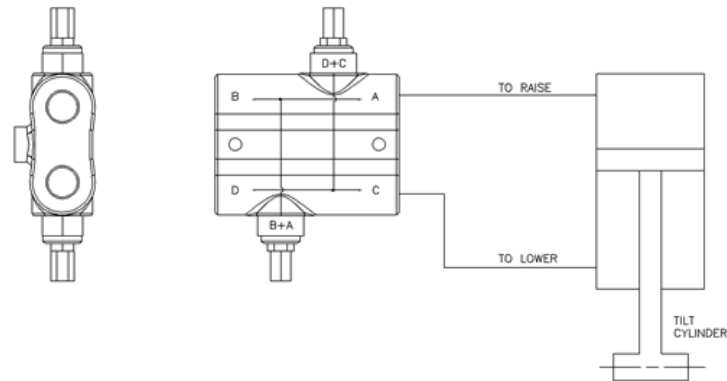

FIGURE 40 – ADJUSTING THE UNDERLIFT CUSHIONING VALVE

1. Completely unfold the underlift.
2. Completely retract the underlift (extension).
3. Try folding the underlift. If it can be folded easily, the cushioning valve is correctly adjusted. If not, continue to the next step.
4. Unscrew the locknut.

NOTE: Make sure to choose the appropriate cushioning valve.

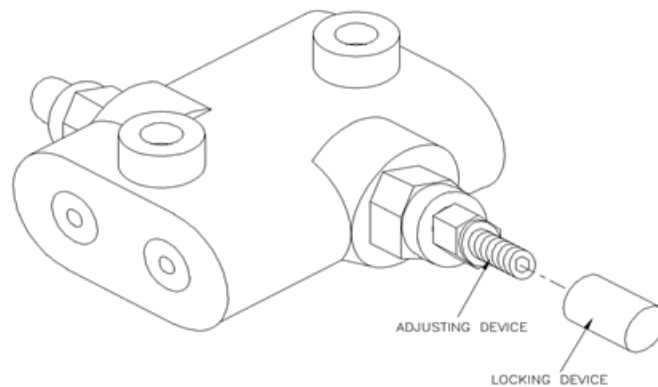

FIGURE 41 – ADJUSTING THE CUSHIONING VALVE

5. Turn the adjusting screw no more than $\frac{1}{4}$ turn at a time.

NOTICE

Do not turn the adjusting screw of the relief valve while operating a hydraulic control, as this may permanently damage the valve.

6. Try folding up the underlift. If it still lacks power, repeat Step 5 until the underlift folds correctly. Do not apply excessive pressure; use the minimum required to fold it correctly.
7. Tighten the locknut.

5 TROUBLESHOOTING

This chapter provides a summary of the most common problems, their main causes and solutions. The following sections provide detailed procedures for some of the solutions.

NOTE: Only distributors are authorized to perform repairs that involve replacing parts.

5.1 Troubleshooting common problems

The following table covers problems that you can solve on your own. If your problem is not listed or you cannot resolve it yourself, contact your distributor.

The list of authorized distributors and service providers is attached.

TABLE 27 - TROUBLESHOOTING

Problem	Causes	Solutions
The levers on the left-hand side control panel don't work	The remote control switch is in the remote control position	Set the remote control switch to the control panel (not remote control) position.
	The PTO is not engaged	Engage the PTO.
	The control panel has no power	Check the DC power (12 VDC in North America and 24 VDC elsewhere) on the main electrical panel (main relay) and check the control panel wiring.
	There is no hydraulic power	Check whether the right-hand side control panel is working. If not, troubleshoot the hydraulic system.
The winches cannot be engaged	The air pressure is too low	Check for an air leak or a bent hose.

Problem	Causes	Solutions
The winches cannot be disengaged	The solenoid has no power	Using a multimeter, see whether the solenoid wiring is carrying a current.
	The air pressure is too low	Check for an air leak or a bent hose.
	The winch solenoid is faulty	Replace the solenoid. Follow the air line to locate the solenoid, which is near the winch.
	The cylinder piston may be broken or bent (only for RPH 15000 winches)	Replace the cylinder.
The wrecker lacks power and runs too slowly	The hydraulic pump is faulty	Check and adjust the hydraulic pressure (see Section 4.4.1 Adjusting the hydraulic pressure (main relief)).
The winch cable stops too quickly or too slowly in free spool mode (disengaged)	The air pressure on the cable tensioner is too low or too high	Increase or decrease the air pressure on the cable tensioner. The regulator is located between the two main winches. This is a trial and error adjustment. Keep adjusting the air pressure of the cable clamp balloon until you find the right setting.
DP winch only: The drag winch cable stops too quickly or too slowly in free spool mode (disengaged)	The drag brake pad is broken or worn out.	Replace the pad.

Problem	Causes	Solutions
The jack legs do not move in one direction, in-and-out or up-and-down (only for jack legs with extendable stabilizers)	Electrical power down on the selector valve solenoid	Check power on wiring to the solenoid with a voltmeter.
	The solenoid for the jack legs is defective	Replace the solenoid. It is located under the aluminum plate at the back of the wrecker.
The slider won't unlock	The solenoid air pressure is too low	Check for an air leak or a bent hose.
	The solenoid wiring is damaged	Check the power and ensure that the solenoid is properly grounded. Replace any damaged wiring.
	The solenoid is burned out	Replace the solenoid. It is located behind the control panel on the right-hand side.
	The locks are jammed	Clean and grease the locks.
	The lock cylinders are damaged	Replace any damaged cylinders.
The underlift is difficult to fold or unfold	The cushioning valve is not adjusted properly	Adjust the cushioning valve (see Section 4.4.3 Adjusting the underlift cushioning valve).
	The pivot pin is jammed	Clean and grease the pin.

Problem	Causes	Solutions
One or more underlift extensions have trouble retracting	The hydraulic pressure is too low	Check the hydraulic pressure (see Section 4.4.1 Adjusting the hydraulic pressure (main relief)).
	The spool on the valve bank is not completing its stroke	Check the neighbouring spool and ensure that the spool completes its stroke. If the spool does not complete its full stroke, something is preventing it from moving freely. Remove the obstruction.
	The wear pads are not in place or sufficiently lubricated	Ensure that all wear pads are in place and well lubricated.
	One or more underlift sections are bent	Use a straight edge to see whether all the underlift sections are straight. If one is bent, have it repaired. You can also remove the steel spacers one by one and see whether that makes a difference.
	The IN/OUT cylinder is diverted	Completely retract the cylinder. Disconnect the very bottom hose from the tail board. Remove the male quick coupler from the hose and put the open end of the hose in a pail. Start the hydraulic system and pull the lever to retract it again, even if it is already retracted. If oil comes out of the hose in the pail, something is wrong with the cylinder. Have it repaired.

Problem	Causes	Solutions
The remote control won't control the equipment	The remote control battery is dead	Recharge the battery. The battery charger is inside the left-hand side control panel.
	The wrecker is being controlled by the control panel	Use the touchscreen interface to activate remote control mode.
	The antenna on the remote control receiver is broken	Replace the antenna. It is located on the right side of the wrecker, just above the oil reservoir.
The boom lowers on its own	The holding valves are not adjusted properly	Adjust the holding valves.
	Rubber or silicone particles in the hydraulic fluid are stuck in the holding valves or cartridges	Fully lower the boom. Loosen the nut that locks the set screw on the cartridge. Turn the set screw clockwise until it stops. This opens the valve completely. Fully retract and extend the boom several times. This flushes the cartridge and may release the particles. Adjust the cartridge (see Section 4.4.2 Adjusting the counterbalance valves (CBCG-LJN)). Try the boom again to see whether the problem is solved.
	The cartridge is faulty	Replace and adjust the cartridge (see Section 4.4.2 Adjusting the counterbalance valves (CBCG-LJN)).
	The boom cylinder is faulty	Check the boom cylinder and have it repaired or rebuilt (see Section 5.2 Checking the boom cylinder).

Problem	Causes	Solutions
The boom extends by itself with a load on the underlift or retracts by itself with a load on the winch cables	There is an external oil leak	Repair any external oil leaks.
	The counterbalance valve is not adjusted properly	Adjust the counterbalance valve (see Section 4.4.2 Adjusting the counterbalance valves (CBCG-LJN)).
	The boom cylinder is faulty	Check the boom cylinder and have it repaired or rebuilt (see Section 5.2 Checking the boom cylinder).

5.2 Checking the boom cylinder

You need to check the boom cylinder if the boom:

- Retracts by itself when lifting a (heavy) load with the winches.
- Extends by itself when lifting a load on the underlift. The underlift tilts down when the boom extends.

The problem might be due to a leaking piston, damaged seal or broken cartridge in the lock valve block.

The following troubleshooting procedure isolates a boom cylinder and checks it for leaks. If you push oil onto one side of a cylinder and the other side is vented, no oil should leak unless there is a broken piston, damaged seal or broken cartridge.

NOTE: You will need a load (e.g. another vehicle) for this procedure.

1. Lower the underlift completely.
2. Choose a lifting point on the vehicle to be towed. It must be both strong enough and have enough clearance for the underlift to move.

DANGER

Using a poor lifting point may damage the towed vehicle and wrecker or even cause a serious accident.

3. Use the safety chains and tensioner to hold the vehicle in place on the underlift's T-bar.
4. Fully retract the boom and keep it retracted using a winch cable hooked to the D-ring on your wrecker.
5. Stop the hydraulic system.

6. For a two-stage boom, disconnect the two hoses from the lock valves coming from the cylinder.

NOTE: Do NOT disconnect the hoses from the cylinder piping.

7. For a three-stage boom, disconnect the two hoses coming from the bottom of the square bushings at the end of the boom cylinder rods.
8. Put a cap on the ends of each hose. This prevents the oil from leaving the cylinder through the hoses.
9. Start the hydraulic system.
10. Disengage the winch that is keeping the boom retracted. If the boom does not stay retracted, the cylinder has to be rebuilt or replaced.

5.3 Checking the PTO

1. Ensure that the hydraulic pump is working.
2. Verify that there is power in the control box. You can try to activate the toggle switch located outside the control box on the left side (the control box is in the left standard toolbox). This switch should route the electrical power to the computer.

This is only a temporary solution. The cause of the problem must be found immediately. Turn off the toggle switch as soon as possible.

6 ACCIDENT OR BREAKDOWN PROCEDURE

This section explains what to do in case of an accident or equipment failure. Your goal is to safely stabilize the equipment and either perform the necessary repairs on site or bring it to a repair location.

Refer to this manual for all operation, maintenance and repair procedures. If in doubt, do not hesitate to contact your distributor. See the list of Authorized distributors and service providers.

6.1 Electrical failure

In the event of an electrical failure, you can use the manual hydraulic levers to safely stabilize the equipment.

WARNING

The electrical failure must be repaired before performing other towing operations.
Contact your distributor to correct the problem.

6.2 Hydraulic failure

In the event of a hydraulic failure, the hydraulic pressures required for normal operation are not reached in the circuits. The hydraulic pump or PTO may be the cause.

⚠ WARNING

The hydraulic failure must be repaired before performing other towing operations.

To troubleshoot a hydraulic failure:

1. Using a component that requires hydraulic pressure (e.g. the boom), check whether the hydraulic pressure shows as normal on the console.
2. Engage the PTO to operate the hydraulic pump and check the console to see whether the PTO engages normally. If the PTO does not engage, have it repaired.
3. If the PTO works normally, check whether the hydraulic pump is operating normally. If the hydraulic pump is not working normally, see Pump Failure below.

When the correct operating pressures are reached, stabilize the equipment safely.

6.3 Pump failure

In the event of a pump failure, the entire hydraulic system will not be functional. If all hydraulic components (boom, jack legs, etc.) are in their stored position, i.e. the position for travel without a load, bring your equipment to a repair location. If some components are not in their stored position, and it is not possible to safely get to a repair point, the pump must be repaired or replaced on site.

6.4 Truck failure

In the event of a vehicle breakdown, you will not be able to operate the equipment. Have the equipment moved to a safe place to make the necessary repairs on the truck.

6.5 Underlift stinger failure

In the event of an underlift stinger failure in which the stinger can no longer be extended or retracted, the most probable cause is a bent cylinder. Remove the underlift and have it repaired.

7 STORAGE

Proper storage is important to prevent premature wear and tear on your machine. Ideally, it should be stored in a dry, covered area.

When storing your wrecker:

1. Immobilize the machine in a dry and stable location.
2. As per Section 4.3 Lubrication, lubricate all parts, including the slider.
3. Position the parts so that the cylinders are fully retracted.
4. Lubricate any exposed cylinder rods.
5. Disconnect the electrical power supply to avoid depleting the batteries.

When taking your wrecker out of storage:

1. Clean and lubricate all parts, including the slider.
2. Replace the high-pressure and return filters on the hydraulic reservoir.
3. Check the oil level and pressure.
4. Connect the electrical power supply.

8 DISASSEMBLY AND DISPOSAL

When the equipment reaches the end of its lifespan, dispose of its various parts in an environmentally friendly manner.

Before disassembling the machine, drain all fluids and remove the battery for recycling.

Comply with all effective regulations, including the RoHS Directive for electrical components, when disassembling the machine and disposing of the following parts:

- Electrical components;
- Rubber hydraulic hoses;
- Painted parts;
- Metal;
- Composite materials.

To protect both you and the environment, we recommend having a specialized company disassemble your machine.

AUTHORIZED DISTRIBUTORS AND SERVICE PROVIDERS

Please visit our website for the list of authorized distributors and service providers, or scan the QR code below.

<https://nrc-industries.com/nrc-dealer/>



LOGBOOK

Your logbook, which must be kept with your equipment, should contain the following information.

Logbook						
Date	Routine	Maintenance/ Frequency (Flushing, Greasing, Tightening...)	Other Tasks (Inspections, Disassembly, Repairs...)	Name and Title	Number of Hours of Operation	Observations (Part Numbers...)

OPERATOR RECORD

Operator Name	Date



NRC-INDUSTRIES.COM

2430 Principale, St-Paul-d'Abbotsford, QC, J0E 1A0

T.450 379.5796 F.450 379.5796