



## OPERATION AND MAINTENANCE

# SLIDING ROTATOR WRECKERS

Model(s): CSR50 - CSR65 - CSR85

Friday, March 13, 2026

Document number: 8923303 — Revision 4.1

Original Instructions

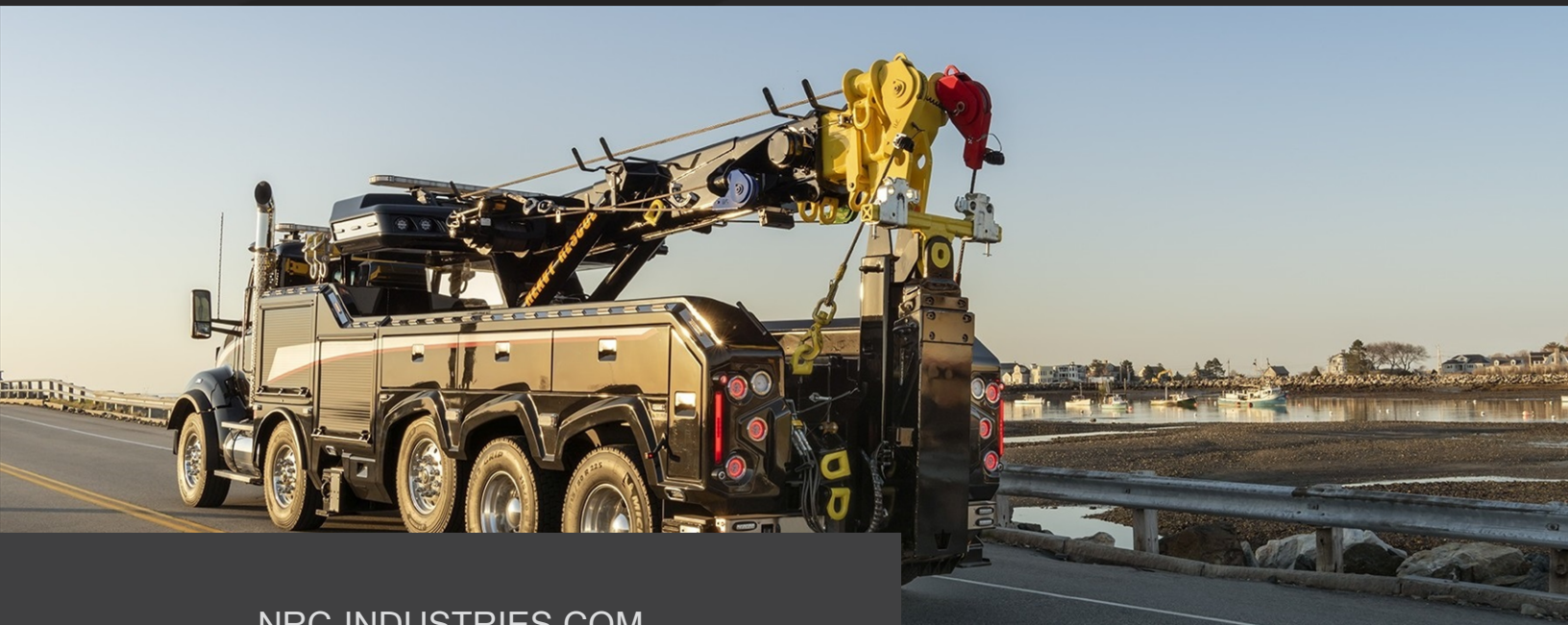

[NRC-INDUSTRIES.COM](http://NRC-INDUSTRIES.COM)

Serial number:





## INTELLECTUAL PROPERTY NOTICE

Copyright © 2026 NRC Industries Inc. All rights reserved. This manual may not be copied, photocopied, reproduced, translated or converted to any electronic or machine-readable format in whole or in part without the prior written approval of NRC Industries Inc. NRC Industries Inc. reserves the right to modify the information provided herein at any time without notice.

Please send your comments and questions to:

NRC Industries Inc.  
2430 Principale St.  
Saint-Paul-d'Abbotsford, QC J0E 1A0  
CANADA  
Tel: (450) 379-5796  
Fax: (450) 379-5995

For any questions about the winches, you can contact the manufacturers directly:

DP Winch (TWG, Inc.)  
PO Box 1130  
Jenks, OK 74037-1130  
Tel: (918) 298-8300  
Fax: (918) 298-8301  
Website: [www.dovertwg.com](http://www.dovertwg.com)

Ramsey Winch Company  
PO Box 581510  
Tulsa, OK 74158-1510  
Tel: (918) 438-2760  
Fax: (918) 438-6688  
Website: [www.ramsey.com](http://www.ramsey.com)



## REVISION HISTORY

Revision	Date	Description
4.1	2026-03-13	Added Figure 8 - V1200 Display (Example) in section 1.1.6. Edited Figures 5, 6, and 7 in section 1.1.6. Edited Tables 3, 4, 6, 7, and 9 in section 1.2. Edited section 1.2.7.
4	2025-08-19	Correction to section 3.5.
3	2024-05-07	Correction to section 4.4.3.
2	2023-09-05	Replaced Figure 49 - Position of the hydraulic pump pressure adjusting screw (CSR85) in section 4.4.1. Added information about the CSR85 oil filters in section 4.3.2. Edited Table 21 - Grease schedule for the sliding base in section 4.3.3.
1	2022-12-12	Correction to section 3.11.1.
0	2022-09-07	Initial release



# CONTENTS

LIMITED WARRANTY .....	9
WARRANTY CARD .....	11
LEGAL STANDARDS AND REQUIREMENTS .....	13
ABOUT THIS MANUAL .....	15
WARNING MESSAGES .....	17
<b>1 DESCRIPTION .....</b>	<b>19</b>
1.1 Description of the wrecker and its components .....	19
1.2 Technical specifications .....	33
<b>2 SAFETY .....</b>	<b>49</b>
2.1 General .....	49
2.2 Safety labels .....	49
2.3 Intended use .....	49
2.4 NRC responsibilities .....	50
2.5 Supervisory responsibilities .....	50
2.6 Operator responsibilities .....	51
2.7 Conditions for use .....	53
<b>3 OPERATION .....</b>	<b>57</b>
3.1 Operating principles .....	57
3.2 Preparing the wrecker for optimal performance .....	62
3.3 Safety guidelines .....	64
3.4 Familiarizing yourself with the equipment .....	65
3.5 Emergency hydraulic bypass .....	66
3.6 Common operating procedures .....	68
3.7 Using the outriggers .....	70
3.8 Using the underlift .....	73
3.9 Using the boom .....	89
3.10 Using the winches .....	92
3.11 Using the remote control .....	94
3.12 Using the touchscreen interface .....	95
<b>4 MAINTENANCE .....</b>	<b>97</b>
4.1 Safety guidelines .....	97
4.2 General maintenance .....	98
4.3 Lubrication .....	107

4.4 Maintenance procedures .....	124
<b>5 TROUBLESHOOTING .....</b>	<b>143</b>
5.1 Troubleshooting common problems .....	144
5.2 Checking the boom cylinder .....	150
<b>6 ACCIDENT OR BREAKDOWN PROCEDURE .....</b>	<b>153</b>
6.1 Electrical failure .....	153
6.2 Hydraulic failure .....	153
6.3 Pump failure .....	154
6.4 Truck failure .....	154
6.5 Underlift stinger failure .....	154
<b>7 STORAGE .....</b>	<b>155</b>
<b>8 DISASSEMBLY AND DISPOSAL .....</b>	<b>157</b>
<b>9 ACCESSORIES .....</b>	<b>159</b>
9.1 Forks and fork holders .....	160
9.2 Holders with integrated forks .....	162
9.3 T-bar brackets .....	164
9.4 Heavy duty tire lifts .....	166
9.5 Medium duty tire lifts .....	168
9.6 Spreader bar .....	170
9.7 Snatch block .....	172
9.8 Drawbar adapter .....	173
9.9 Wood pads .....	175
9.10 Stabilizer grips .....	177
9.11 Chains (tow chains and safety chains) .....	179
<b>AUTHORIZED DISTRIBUTORS AND SERVICE PROVIDERS .....</b>	<b>181</b>
<b>LOGBOOK .....</b>	<b>183</b>
<b>OPERATOR RECORD .....</b>	<b>185</b>

## LIMITED WARRANTY

**A. GENERAL PROVISIONS** - THE WARRANTY DESCRIBED BELOW IS PROVIDED BY INDUSTRIES NRC INC, 2430 PRINCIPALE EST C.P. 160, ST-PAUL D'ABBOTSFORD, QUÉBEC, CANADA, J0E 1A0 ("INDUSTRIES NRC") TO THE ORIGINAL PURCHASER OF NEW TOWING AND RECOVERY EQUIPMENT ("EQUIPMENT") PURCHASED FROM INDUSTRIES NRC OR AUTHORIZED INDUSTRIES NRC DEALERS. UNDER THIS WARRANTY, INDUSTRIES NRC WILL REPAIR OR REPLACE, AT ITS OPTION, ANY PART COVERED UNDER THIS WARRANTY WHICH IS FOUND TO BE DEFECTIVE IN MATERIAL OR WORKMANSHIP DURING THE APPLICABLE WARRANTY TERM. WARRANTY SERVICE MUST BE PERFORMED BY A DEALER OR SALES SERVICE CENTRE AUTHORIZED BY INDUSTRIES NRC TO SELL AND/OR SERVICE THE EQUIPMENT (THE "AUTHORIZED DEALER"). THE AUTHORIZED DEALER WILL USE ONLY NEW OR REMANUFACTURED PARTS OR COMPONENTS FURNISHED OR APPROVED BY INDUSTRIES NRC. WARRANTY SERVICE WILL BE PERFORMED WITHOUT CHARGE TO THE PURCHASER FOR PARTS. HOWEVER, THIS WARRANTY DOES NOT OBLIGATE INDUSTRIES NRC TO BEAR THE COST OF LABOR OR TRANSPORTATION CHARGES IN CONNECTION WITH THE REPAIR OR REPLACEMENT OF ANY PARTS FOUND TO BE DEFECTIVE, NOR SHALL IT APPLY TO A PRODUCT UPON WHICH REPAIRS OR ALTERATIONS HAVE BEEN MADE UNLESS AUTHORIZED BY INDUSTRIES NRC. THE PURCHASER WILL BE RESPONSIBLE FOR SERVICE CALLS AND/OR TRANSPORTATION OF EQUIPMENT TO AND FROM THE AUTHORIZED DEALER'S PLACE OF BUSINESS (EXCEPT WHERE PROHIBITED BY LAW), FOR ANY PREMIUM CHARGED FOR OVERTIME LABOUR REQUESTED BY THE PURCHASER AND FOR ANY SERVICE AND/OR MAINTENANCE NOT DIRECTLY RELATED TO ANY DEFECT COVERED UNDER THIS WARRANTY. THIS WARRANTY IS TRANSFERABLE, PROVIDED AN AUTHORIZED INDUSTRIES NRC DEALER IS NOTIFIED OF THE OWNERSHIP CHANGE, AND INDUSTRIES NRC APPROVES THE TRANSFER.

**B. WHAT IS WARRANTED** - SUBJECT TO PARAGRAPH C, ALL PARTS, MANUFACTURED BY INDUSTRIES NRC, OF ANY NEW INDUSTRIES NRC EQUIPMENT, ARE WARRANTED FOR THE NUMBER OF MONTHS SPECIFIED BELOW. WARRANTY STATEMENTS COVERING COMPONENTS NOT MANUFACTURED BY NRC ARE FOUND WITH THE OPERATOR'S MANUALS DELIVERED WITH THE EQUIPMENT.

**C. WHAT IS NOT WARRANTED** - PURSUANT TO THE TERMS OF THIS WARRANTY, INDUSTRIES NRC IS NOT RESPONSIBLE FOR THE FOLLOWING: (1) USED EQUIPMENT (UNLESS IT IS SPECIFICALLY COVERED BY SEPARATE WARRANTY DOCUMENTS); (2) ANY EQUIPMENT THAT HAS BEEN ALTERED OR MODIFIED IN WAYS NOT APPROVED BY INDUSTRIES NRC, INCLUDING, BUT NOT LIMITED TO, HYDRAULIC PRESSURE SETTINGS ABOVE INDUSTRIES NRC SPECIFICATIONS; (3) DEPRECIATION OR DAMAGE CAUSED BY NORMAL WEAR, LACK OF REASONABLE AND PROPER MAINTENANCE, FAILURE TO FOLLOW OPERATING INSTRUCTIONS, MISUSE, LACK OF PROPER PROTECTION DURING STORAGE, VANDALISM, THE ELEMENTS OR COLLISION OR ACCIDENT; (4) THE EQUIPMENT IF USED FOR OVERHEAD LIFTING, CRANE WORK OR ANY OTHER UNAPPROVED ACTIVITY; (5) NORMAL MAINTENANCE PARTS AND/OR SERVICE.

**D. SECURING WARRANTY SERVICE** - TO SECURE WARRANTY SERVICE THE PURCHASER MUST, (1) REPORT THE EQUIPMENT DEFECT TO AN AUTHORIZED DEALER AND REQUEST WARRANTY SERVICE WITHIN THE APPLICABLE WARRANTY TERM; (2) PRESENT EVIDENCE OF THE WARRANTY START DATE TOGETHER WITH THE VALID PROOF OF PURCHASE; AND, (3) MAKE THE EQUIPMENT AVAILABLE TO AN AUTHORIZED DEALER OR SERVICE CENTRE WITHIN A REASONABLE PERIOD OF TIME.

**E. NO IMPLIED WARRANTY, REPRESENTATION OR CONDITION** - TO THE EXTENT PERMITTED BY LAW, NEITHER INDUSTRIES NRC NOR ANY COMPANY AFFILIATED WITH IT MAKES ANY WARRANTY, REPRESENTATION, CONDITION OR PROMISE, EXPRESS OR IMPLIED, VERBAL OR OTHERWISE, AS TO THE QUALITY, PERFORMANCE OR FREEDOM FROM DEFECT OF THE EQUIPMENT. NO IMPLIED OR STATUTORY CONDITIONS OR WARRANTIES OF MERCHANTABILITY OR FITNESS (WHETHER PURSUANT TO THE SALE OF GOODS ACT OR ANY OTHER STATUTE OF ANY PROVINCE/STATE OR OTHERWISE) ARE MADE.

**F. EXCLUSIVE REMEDY** - TO THE EXTENT PERMITTED BY LAW, THE PURCHASER'S EXCLUSIVE REMEDY IN CONNECTION WITH THE BREACH OR PERFORMANCE OF ANY WARRANTY ON THE EQUIPMENT ARE THOSE SET FORTH IN THIS WARRANTY. IN NO EVENT WILL AN AUTHORIZED DEALER, INDUSTRIES NRC OR ANY COMPANY AFFILIATED WITH INDUSTRIES NRC, BE LIABLE FOR ANY INCIDENTAL OR CONSEQUENTIAL DAMAGES OR INJURIES, INCLUDING BUT NOT LIMITED TO, LOSS OF PROFITS, RENTAL OF SUBSTITUTE EQUIPMENT, OTHER COMMERCIAL OR PERSONAL LOSS OR DAMAGES ARISING AS A RESULT OF A FUNDAMENTAL BREACH OR BREACH OF A FUNDAMENTAL TERM.

**G. NO DEALER WARRANTY** - EXCEPT FOR CONDITIONS OR WARRANTIES WHICH MAY NOT BE EXCLUDED BY LAW, THE SELLING DEALER MAKES NO WARRANTY OF ITS OWN ON ANY ITEM WARRANTED BY INDUSTRIES NRC, AND MAKES NO WARRANTY ON OTHER ITEMS UNLESS IT DELIVERS TO THE PURCHASER A SEPARATE WRITTEN WARRANTY DOCUMENT SPECIFICALLY WARRANTING THE ITEM. THE SELLING DEALER HAS NO AUTHORITY TO MAKE ANY REPRESENTATION OR PROMISE ON BEHALF OF INDUSTRIES NRC OR TO MODIFY THE TERMS OR LIMITATIONS OF THIS WARRANTY IN ANY WAY.

**H. WARRANTY TERMS**

**EQUIPMENT**

**TERMS**

TRUCK MOUNTED RECOVERY EQUIPMENT

12 MONTHS FROM "IN SERVICE" DATE. NO MORE THAN 24 MONTHS.

SLIDING SYSTEM COMPONENTS

10 YEARS FROM DATE OF MANUFACTURING.

TOWING ACCESSORIES MANUFACTURED BY INDUSTRIES NRC

12 MONTHS FROM DATE OF MANUFACTURING.

ACCESSORIES MANUFACTURED BY A THIRD PARTY

THIRD PARTY WARRANTY APPLIES.

## WARRANTY REGISTRATION FORM



On the date of sale I have read the NRC Warranty Agreement, I understand its terms & conditions, and acknowledge receipt of my copy of the agreement.  
PLEASE PRINT CLEARLY OR TYPE.

INFORMATION ON THE CHASSIS ON WHICH THE NRC UNIT IS INSTALLED																
IMPERIAL (lbs,mi) <input type="checkbox"/>	METRIC (kg,km) <input type="checkbox"/>	Used <input type="checkbox"/>	New <input type="checkbox"/>													
GVWR :	FRONT	REAR														
MAKE :	MODEL	YEAR														
VEHICLE IDENTIFICATION NUMBER (CHASSIS)												MILEAGE				

NRC UNIT  
Date of Sale : \_\_\_\_\_

First Puschaser's Name  
\_\_\_\_\_

NRC Serial # \_\_\_\_\_  
Axle-lift  
Serial # \_\_\_\_\_

Address : \_\_\_\_\_  
\_\_\_\_\_

NRC Model # \_\_\_\_\_

Postal / Zip code : \_\_\_\_\_

Date of Delivery to Dealer :  
\_\_\_\_\_

Purchaser's Company Title / Position  
\_\_\_\_\_

Dealer Name :  
\_\_\_\_\_

Purchaser's Signature :  
X \_\_\_\_\_

Address : \_\_\_\_\_  
\_\_\_\_\_

Date : \_\_\_\_\_

Postal / Zip code : \_\_\_\_\_

Primary Contact-Necessary for Warranty-Admin

Dealer Signature : \_\_\_\_\_

Name : \_\_\_\_\_

Date : \_\_\_\_\_

Phone : \_\_\_\_\_

The following items are to be performed by dealer at the time of vehicle delivery. Customer to sign off each item as verification that it was performed.			
	Completed the NRC Warranty Registration Form		Explain required maintenance program to Customer
	Customer instructed on the safe and proper operation of the unit purchased.		
	Explain and demonstrate vehicle and Accessory operation to Customer.		Present completed Warranty registration. Copy to Customer & fax copy to NRC Warranty Department.
	PRE-DELIVERY INSPECTION		Customer Signature

This Warranty is not valid until approved by NRC Industries and all items on this form completed.



## LEGAL STANDARDS AND REQUIREMENTS

The NRC sliding rotator wreckers featured in this manual meet the following legal standards and requirements:

### CE

	CE	Rest of world
2006/42/CE	X	
2014/30/UE	X	
2014/53/UE	X	
768/2008/CE	X	

### Harmonized standards

	CE	Rest of world
EN 60204-1	X	
EN 82079-1	X	
EN ISO 12100	X	
EN 14492-1 (for the winches)	X	

### Other standards

	CE	Rest of world
SAE J2512		X
SAE J706 (for the winches)		X
FMVSS/CMVSS 108 (Canada and USA)		X



## ABOUT THIS MANUAL

This manual contains important information about how to safely operate and maintain your NRC sliding rotator wrecker. Read it before operating the machine and retain it for future reference during the entire lifespan of the machine.

This manual contains the following chapters:

- Chapter 1 presents the wrecker models, their components and their technical specifications.
- Chapter 2 provides safety information for operating, maintaining and troubleshooting the wrecker.
- Chapter 3 provides operating principles and procedures.
- Chapter 4 provides maintenance information and procedures.
- Chapter 5 provides troubleshooting information and procedures.
- Chapter 6 provides the operating method in case of an accident or equipment breakdown.
- Chapter 7 provides information about taking the wrecker in and out of storage.
- Chapter 8 provides information for disassembling and disposing of the wrecker.
- Chapter 9 contains information about the accessories that can be used with the equipment.

## Document conventions

The following conventions are used throughout this document:

**NOTE:** We highly recommend that you read this manual in full before using your NRC equipment.

## Disclaimer

This manual, including the equipment specifications, is subject to change without notice. Ensure that you have the latest version of this manual before using your equipment.

All ratings are based on structural factors only, not vehicle capacities or capabilities.

## Applicable models and serial numbers

This manual is intended for use with the following models with serial numbers within the following ranges only:

- CSR50-001 to ...
- CSR65-001 to ...
- CSR85-001 to ...

## WARNING MESSAGES

### **DANGER**

**DANGER** - Immediate hazards or unsafe practices that will result in severe personal injury or death.

### **WARNING**

**WARNING** - Hazards or unsafe practices that could result in severe personal injury or death.

### **CAUTION**

**CAUTION** - Hazards or unsafe practices that could result in minor personal injury or equipment damage.

### **NOTICE**

Indicates information that should be read to avoid equipment damage.



# 1 DESCRIPTION

The NRC sliding rotator wrecker is a dream machine, a tough and versatile unit for recovery work and extra-heavy towing. Specially designed for the most difficult tasks, the sliding rotator wrecker lifts loads more easily and quickly than competing models.

This chapter describes the components of the CSR50, CSR65 and CSR85 wrecker models and lists their technical specifications.

## 1.1 Description of the wrecker and its components

NRC sliding rotator wreckers are manufactured with the same main components. Only their sizes and capacities are different. See Section 1.2 Technical specifications for the wrecker model specifications.

Seven underlift models are available and can be installed on any sliding rotator system model:

- **HD-3:** Heavy Duty – three-stage
- **HDE-3:** Heavy Duty Euro – three-stage
- **SHD-3:** Super Heavy Duty – three-stage
- **LSHDE-3:** Long Super Heavy Duty Euro – three-stage
- **XSHDE-3:** Extra Long Super Heavy Duty Euro – three-stage
- **SSHD-4:** Short Super Heavy Duty – four-stage
- **LSHD-4:** Long Super Heavy Duty – four-stage

The following sections outline the chassis, boom and underlift characteristics.

### 1.1.1 Chassis

The chassis supports all the wrecker components, which are shown in Figure 1.

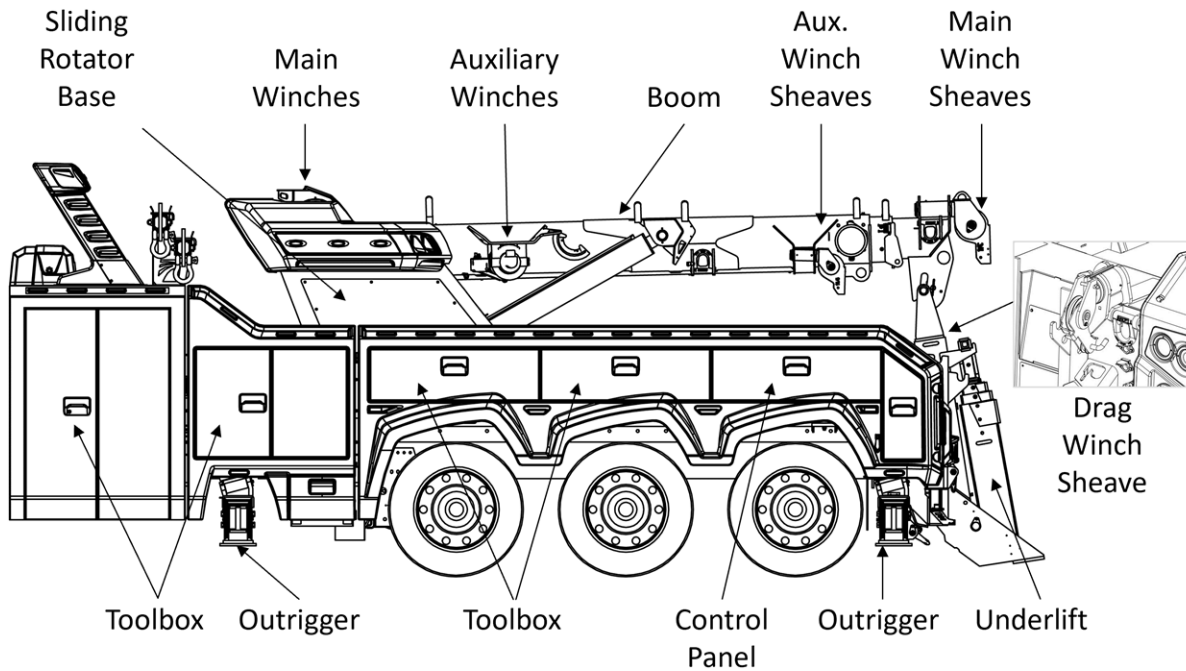

**FIGURE 1 – CHASSIS AND WRECKER COMPONENTS (EXAMPLE)**

## 1.1.2 Outriggers

The wrecker has four three-stage outriggers: front-left, front-right, rear-left and rear-right. Figure 2 shows the outrigger components.

NOTE: The three-stage and two-stage outriggers are used the same way.

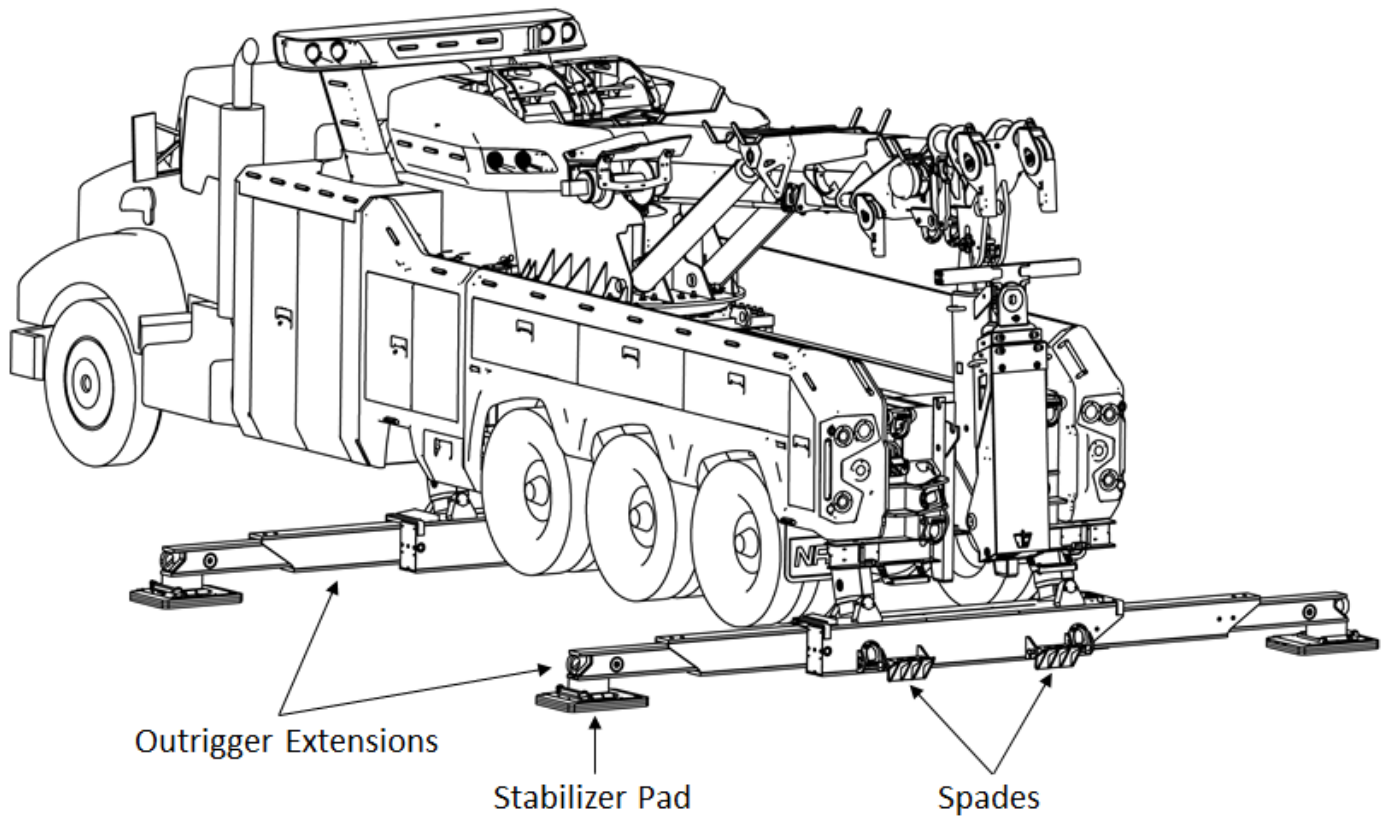

FIGURE 2 – OUTRIGGERS (EXAMPLE)

### 1.1.3 Boom

Figure 3 shows a three-section boom and its components.

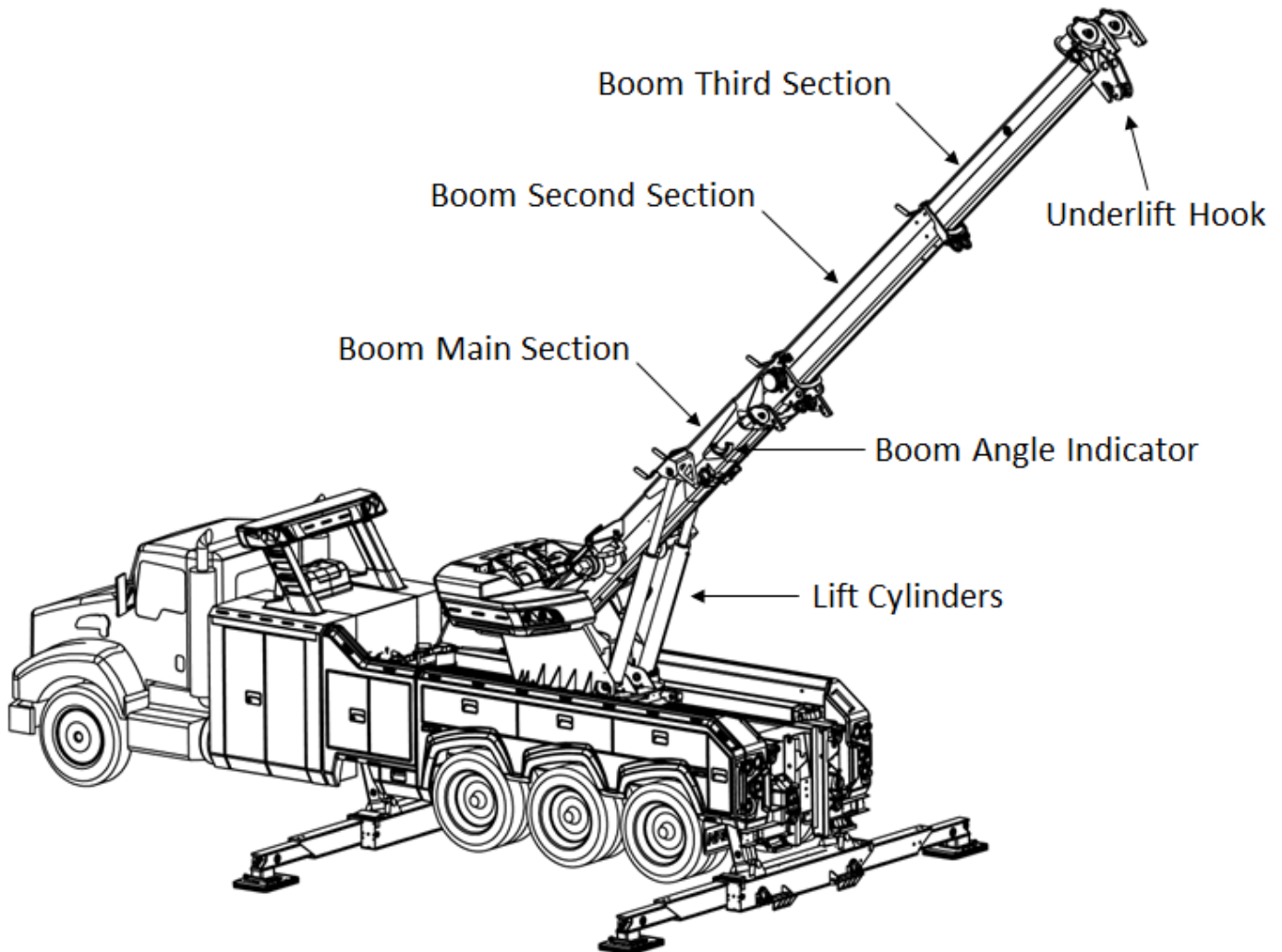

FIGURE 3 – BOOM (EXAMPLE)

### 1.1.4 Winch

The wrecker is equipped with up to five winches: 2 main winches, 2 auxiliary winches (optional), and 1 drag winch (optional and attached to the sliding base). Figure 1 shows the location of each type of winch.

### 1.1.5 Underlift

The underlift has a vertical section, a horizontal telescopic stinger and a T-bar, as shown in Figure 4. The horizontal stinger can be extended and retracted to allow the T-bar to reach the vehicle to be towed.

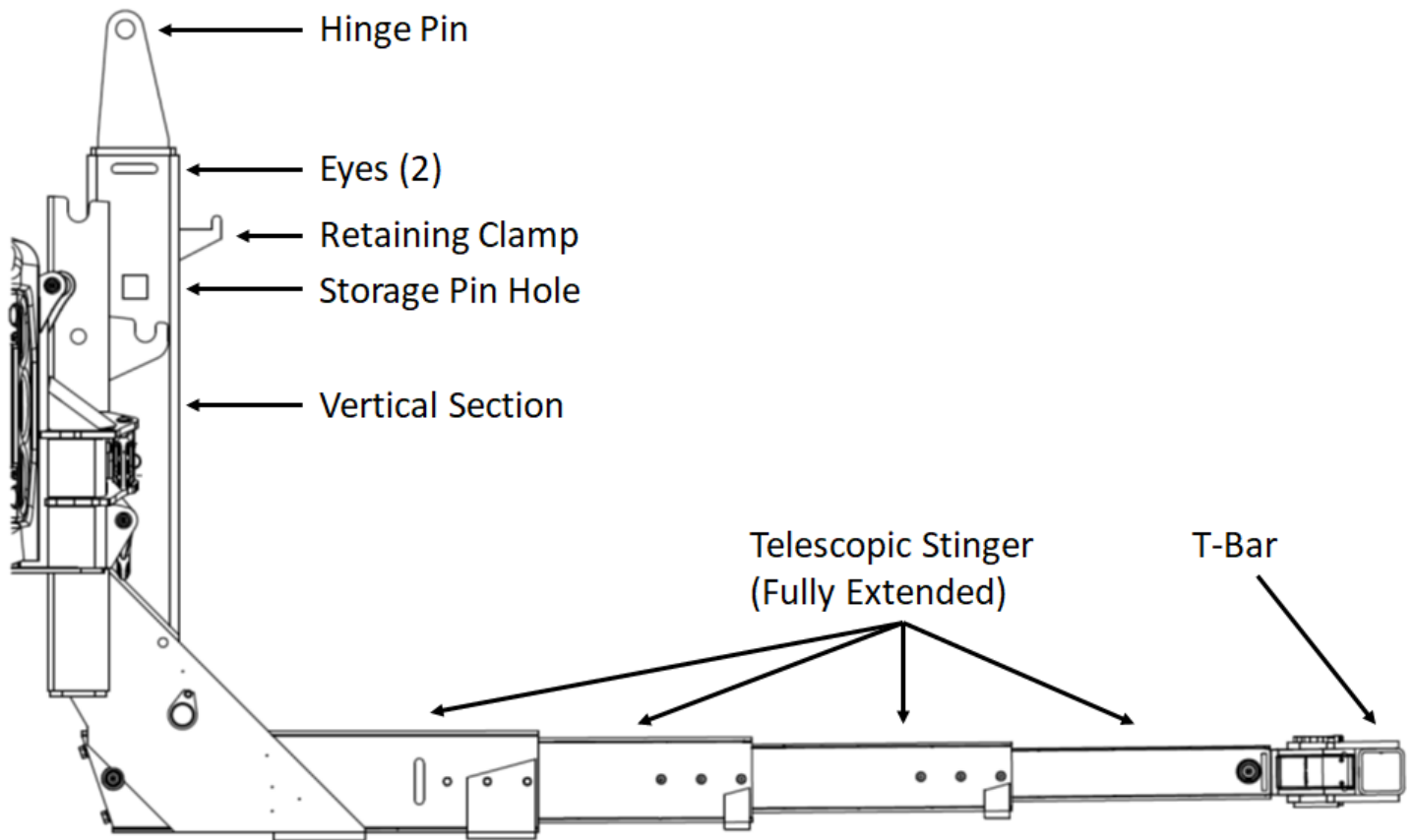

FIGURE 4 – UNDERLIFT (EXAMPLE)

### 1.1.6 Control panels

The wrecker features up to 2 electronic control panels, located inside the rear cabinets, on the left-hand side and/or right-hand side of the vehicle. An emergency manual override control panel is located in the centre cabinet on the left-hand side.

The controls are proportional. This means that the further the levers are moved, the more the speed and power increase. Proportional controls allow you to use very slow speeds for greater precision and maximum control of the load.

Figure 5 shows the electronic control panel on the left-hand side, and Table 1 explains the pictograms used to identify the various controls and switches. These brief descriptions are not operating instructions; to learn how to operate the components, see the procedures in the relevant sections of this manual.

**NOTE:** The position and number of controls may differ slightly between models.

Figure 6 and Figure 7 show the display panel on the left-hand side. See the MD4-7 manual for a description of the touchscreen and how to operate your wrecker using the touchscreen interface.

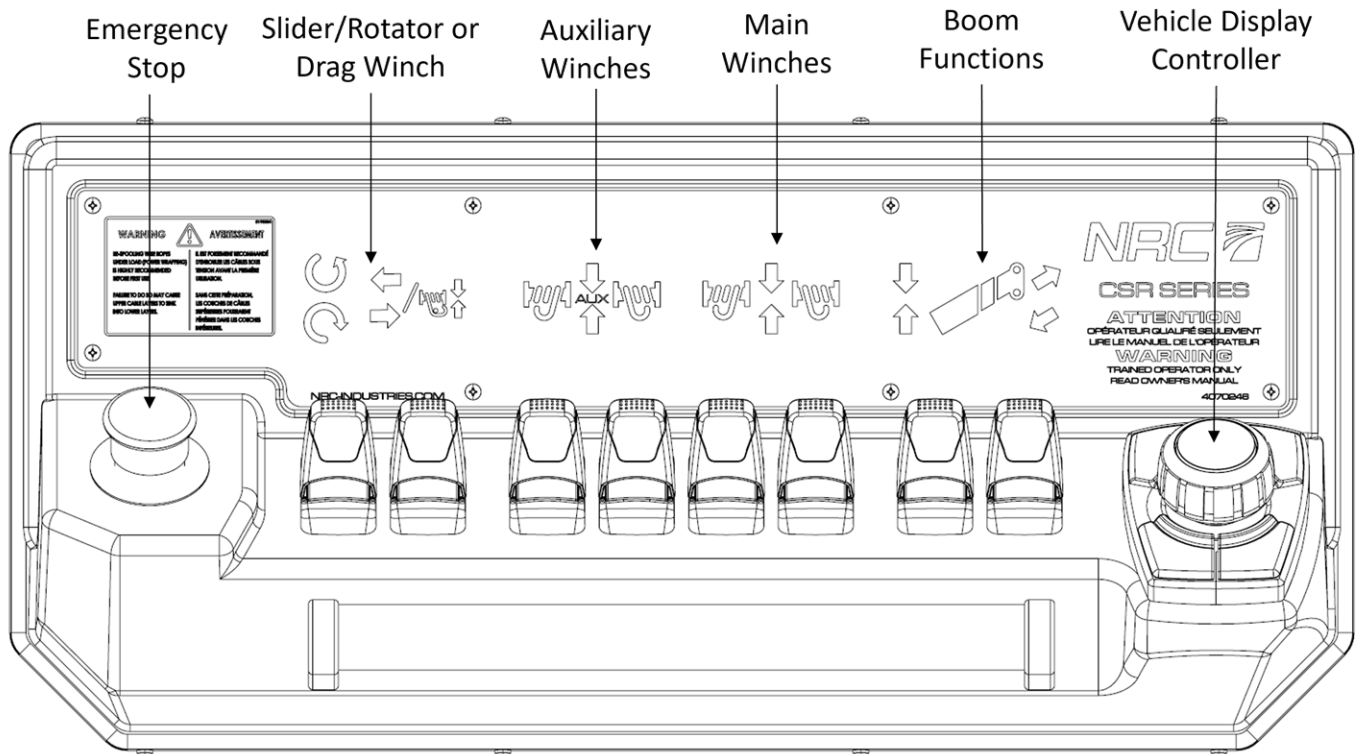

FIGURE 5 – CONTROL PANEL (LEFT-HAND SIDE) (EXAMPLE)

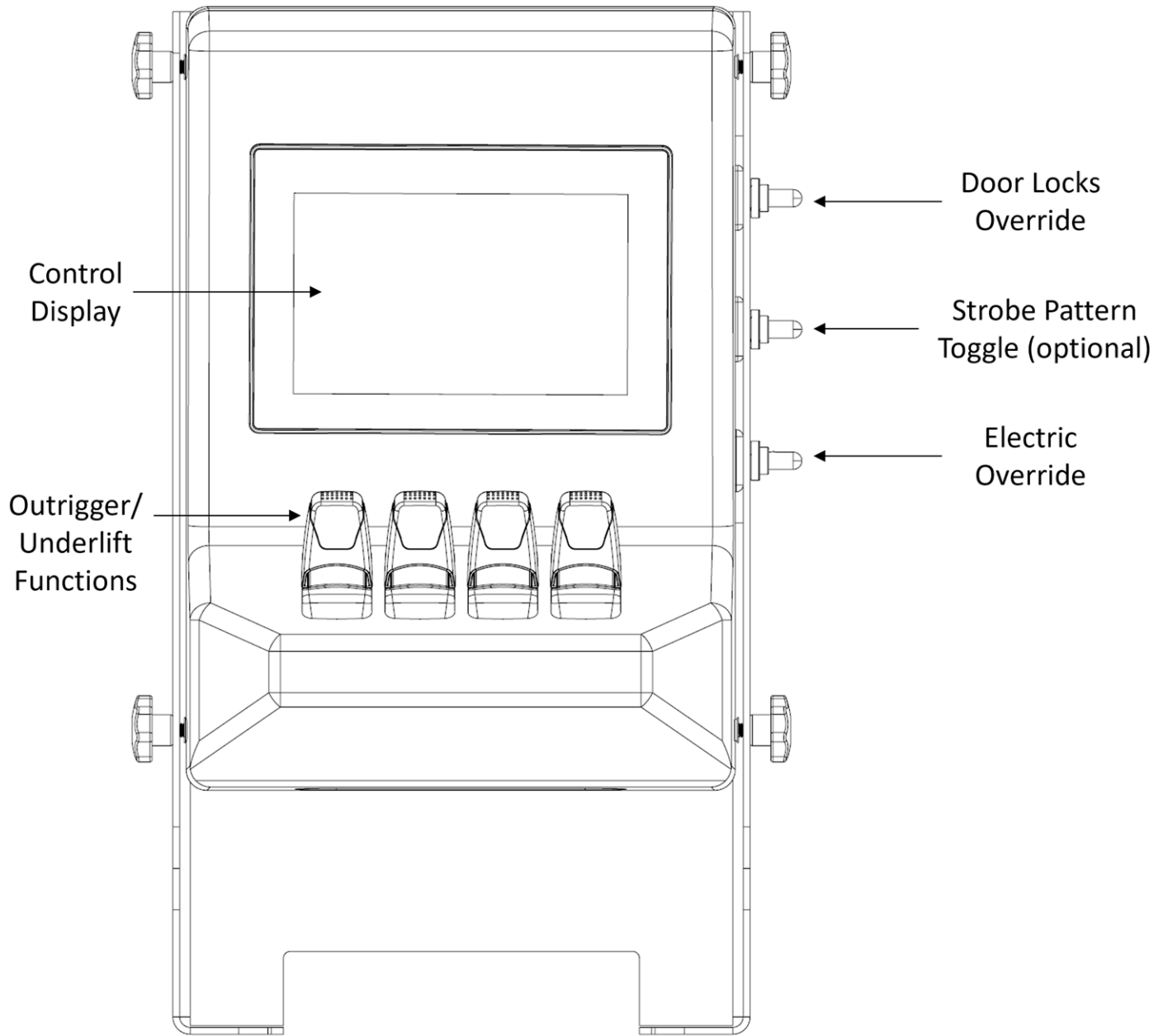
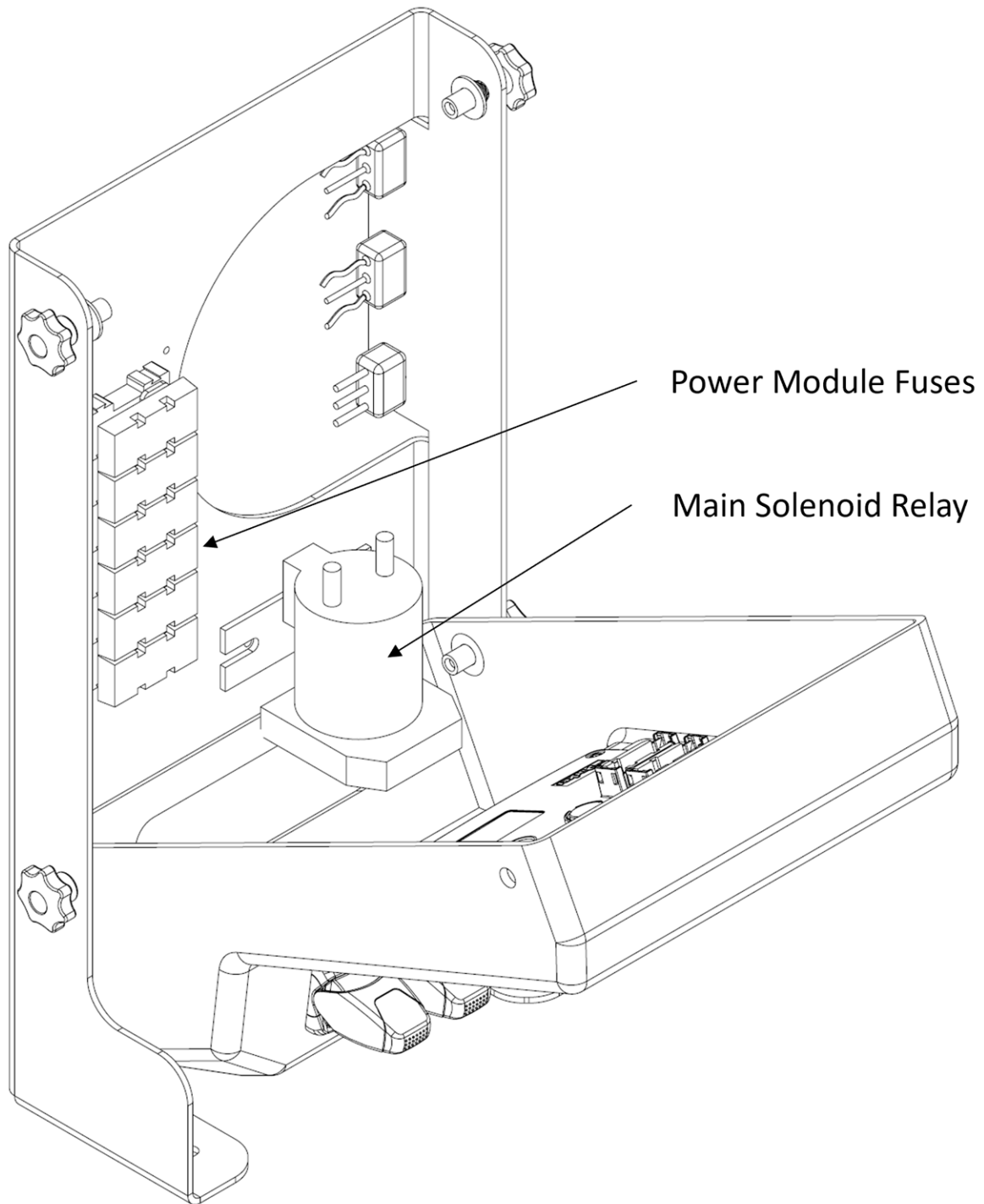
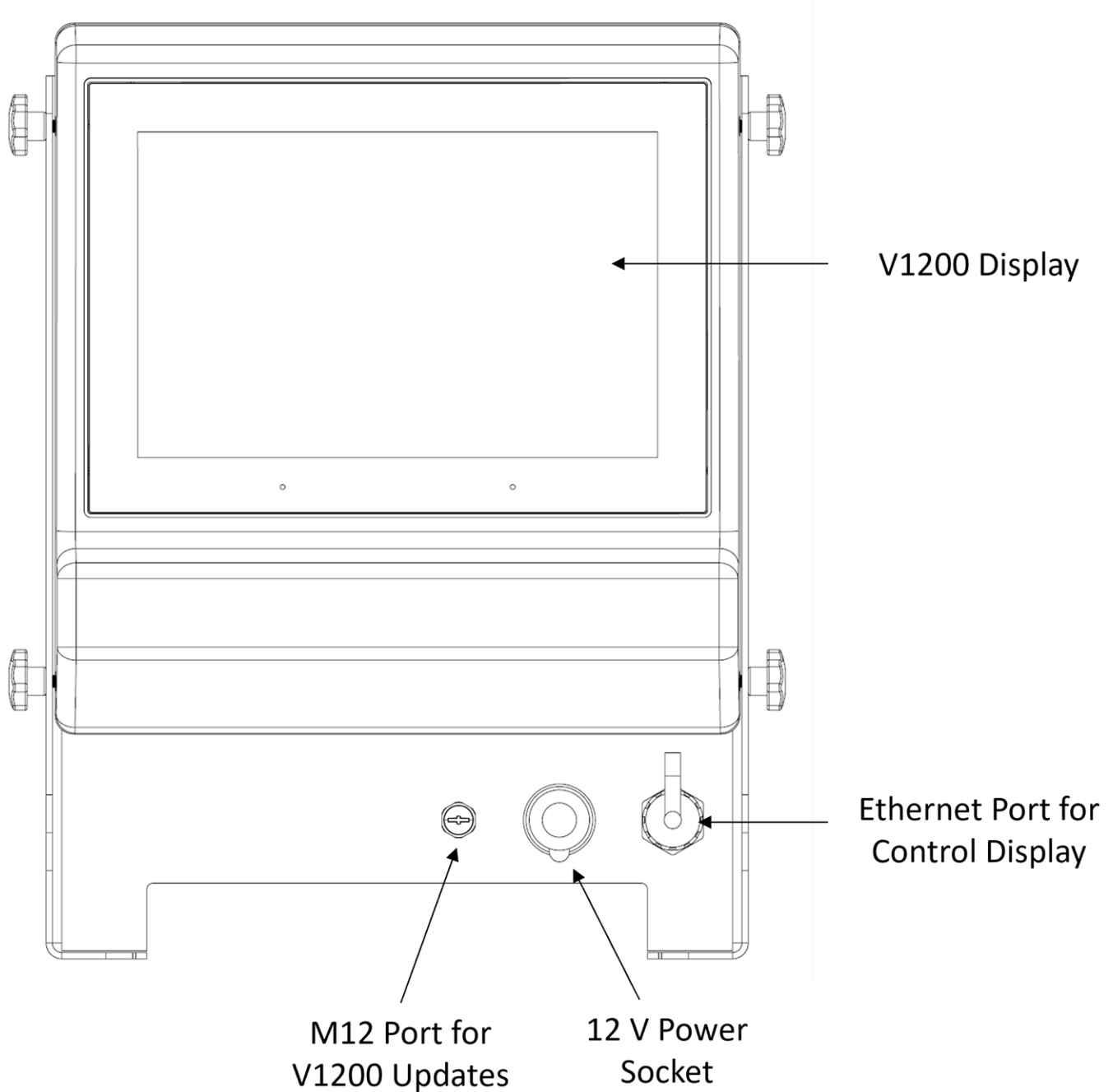

FIGURE 6 – DISPLAY PANEL, CLOSED (LEFT-HAND SIDE) (EXAMPLE)



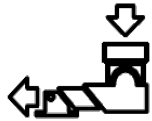





**FIGURE 7 – DISPLAY PANEL, OPEN (LEFT-HAND SIDE) (EXAMPLE)**



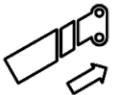



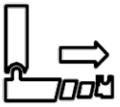
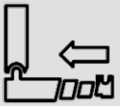

Figure 8 shows the V1200 display. See the V1200 manual for a description of the touchscreen and how to operate your wrecker using the touchscreen interface.



**FIGURE 8 – V1200 DISPLAY (EXAMPLE)**

TABLE 1 – CONTROL PANEL LEVERS

Element	Description
Outriggers (to operate the outriggers, see Section 3.7)	
	<p>Retracts the left outrigger when the direction switch is set to horizontal.                      Raises the left outrigger when the direction switch is set to vertical.</p>
	<p>Extends the left outrigger when the direction switch is set to horizontal.                      Lowers the left outrigger when the direction switch is set to vertical.</p>
	<p>Retracts the right outrigger when the direction switch is set to horizontal.                      Raises the right outrigger when the direction switch is set to vertical.</p>
	<p>Extends the right outrigger when the direction switch is set to horizontal.                      Lowers the right outrigger when the direction switch is set to vertical.</p>
Boom (to operate the boom, see Section 3.9)	
	<p>Rotates the boom counter-clockwise (when the boom rotation is unlocked).</p>
	<p>Rotates the boom clockwise (when the boom rotation is unlocked).</p>
	<p>Moves the boom toward the front of the wrecker (when the slider is unlocked).</p>
	<p>Moves the boom toward the rear of the wrecker (when the slider is unlocked).</p>

Element	Description
	Lowers the boom.
	Raises the boom.
	Extends the boom.
	Retracts the boom.
Winches (to operate the winches, see Section 3.10)	
	Unwinds the winch cables.
	Winds the winch cables.
Underlift (to operate the underlift, see Section 3.8)	
	Extends the underlift.
	Retracts the underlift.
	Unfolds the underlift stinger.
	Folds the underlift stinger.

### 1.1.7 Remote control

Your wrecker may be equipped with a remote control. The remote control features most of the functions that are available on the main control panels of the wrecker.

Figure 9 shows a remote control, and Table 2 explains the pictograms that are unique to the remote control. Table 1 explains the remaining pictograms, which are also used on the control panels.

These brief descriptions are not operating instructions; to learn how to operate the components, see the procedures in the relevant sections of this manual.

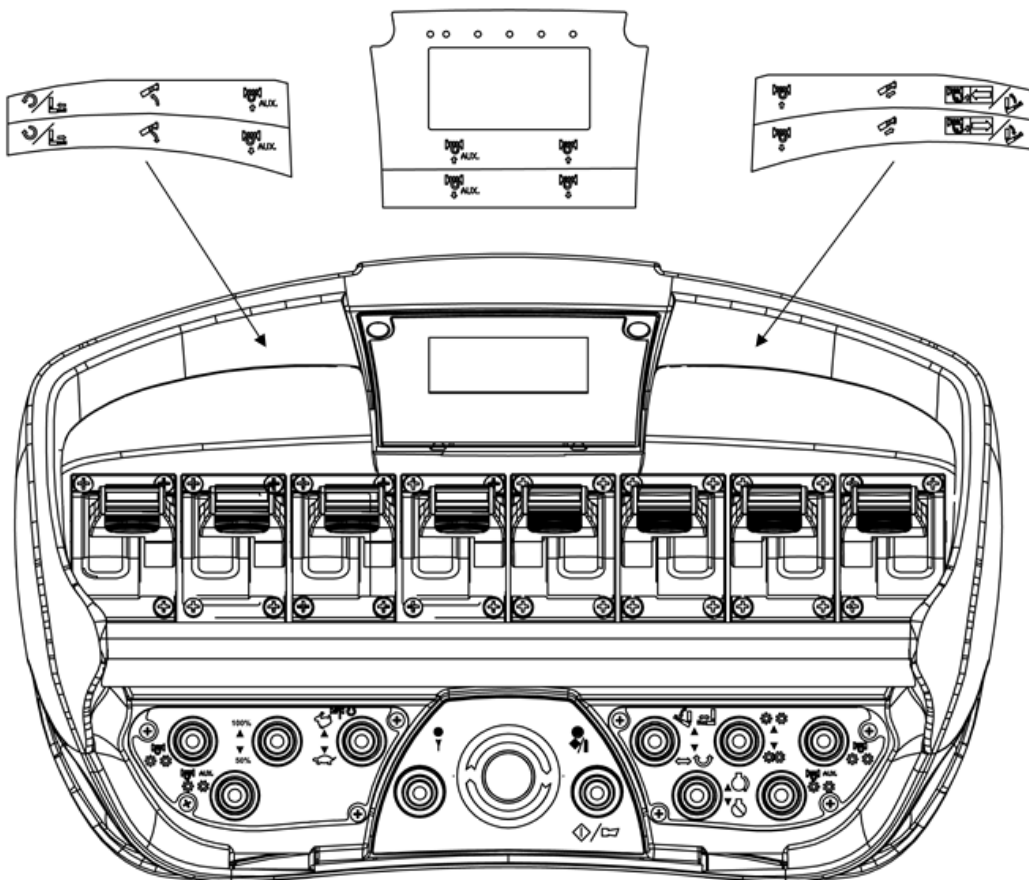



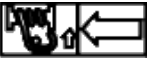



FIGURE 9 – REMOTE CONTROL (EXAMPLE)

TABLE 2 – REMOTE CONTROL SWITCHES, BUTTONS AND LEVERS

Element	Description
	Starts and stops the engine.
	Sounds the horn.
	Turns the remote control ON or OFF.
50% / 100%	Activates half-speed or full-speed operation. This switch only controls the remote control functions (it has no effect on the control panel functions).
	Determines whether the remote control will operate the drag winch or the slider (If your wrecker has this option, you can select one of these settings on the wrecker's control panel).
	Toggles between control of the boom rotation and slider and control of the underlift.

For more information, see Section 1.1.6 Control panels.

### 1.1.8 Hydraulic and pneumatic system

The CSR50, CSR65 and CSR85 models feature an electro-hydraulic system that supplies and distributes hydraulic power to the boom, underlift, etc.

### 1.1.9 Electrical system

The CSR50, CSR65 and CSR85 models feature an electrical system that supplies the electrical power for operating the wrecker’s electrical components. The electrical system includes a main electrical panel with breakers and relays that distributes the electricity to the valve banks, electronic control modules, sensors and lights.

## 1.2 Technical specifications

The following sections list the technical specifications for the components of the CSR50, CSR65 and CSR85 wrecker models.

### 1.2.1 General specifications

TABLE 3 – GENERAL SPECIFICATIONS (IN METRIC [IMPERIAL])

Element	CSR50	CSR65	CSR85
Boom capacity	445 kN [50 tons]	578 kN [65 tons]	756 kN [85 tons]
Test lifting capacity	445 kN [50 tons]	578 kN [65 tons]	756 kN [85 tons]
Boom capacity: fully retracted	445 kN [100,000 lb.]	578 kN [130,000 lb.]	756 kN [170,000 lb.]
Boom capacity: fully extended	89 kN [20,000 lbf]	125 kN [28,000 lbf]	103 kN [23,100 lbf]
Effective reach with 3-stage boom	7,620 mm [300"]	9,474 mm [373"]	12,065 mm [475"]
Maximum working height with 3-stage boom	11.2 m [440"]	13.4 m [530"]	16.8 m [663"]
Boom lifting range	0–64°	0–70°	0–70°
Approximate wrecker weight: excluding chassis	16,750 kg [37,000 lb.]	21,300 kg [47,000 lb.]	28,100 kg [62,000 lb.]
Approximate wrecker weight: including carrier truck	27,000 kg [59,500 lb.]	32,650 kg [72,000 lb.]	40,350 kg [89,000 lb.]
Body width	2,590 mm [102"]	2,590 mm [102"]	2,590 mm [102"]
Distance from back of cab to centre of rearmost axle	5,025 mm + [198" +]	6,250 mm + [246" +]	7,135 mm + [281" +]

## 1.2.2 Chassis

TABLE 4 – CHASSIS SPECIFICATIONS (IN METRIC [IMPERIAL])

Element	CSR50	CSR65	CSR85
Front axle (minimum)	8 tonnes [18,000 lb.]	9 tonnes [20,000 lb.]	18 tonnes [40,000 lb.]
Rear axle (minimum)	21 tonnes [46,000 lb.]	30 tonnes [66,000 lb.]	30 tonnes [66,000 lb.]
Chassis resisting bending moment (RBM) (minimum)	508 kN-m [4,500,000 lb.-in.]	508 kN-m [4,500,000 lb.-in.]	621 kN-m [5,500,000 lb.-in.]

### 1.2.3 Dimensions

Figure 10 to Figure 14 and Table 5 to Table 8 present the dimensions of the wrecker models and their components.

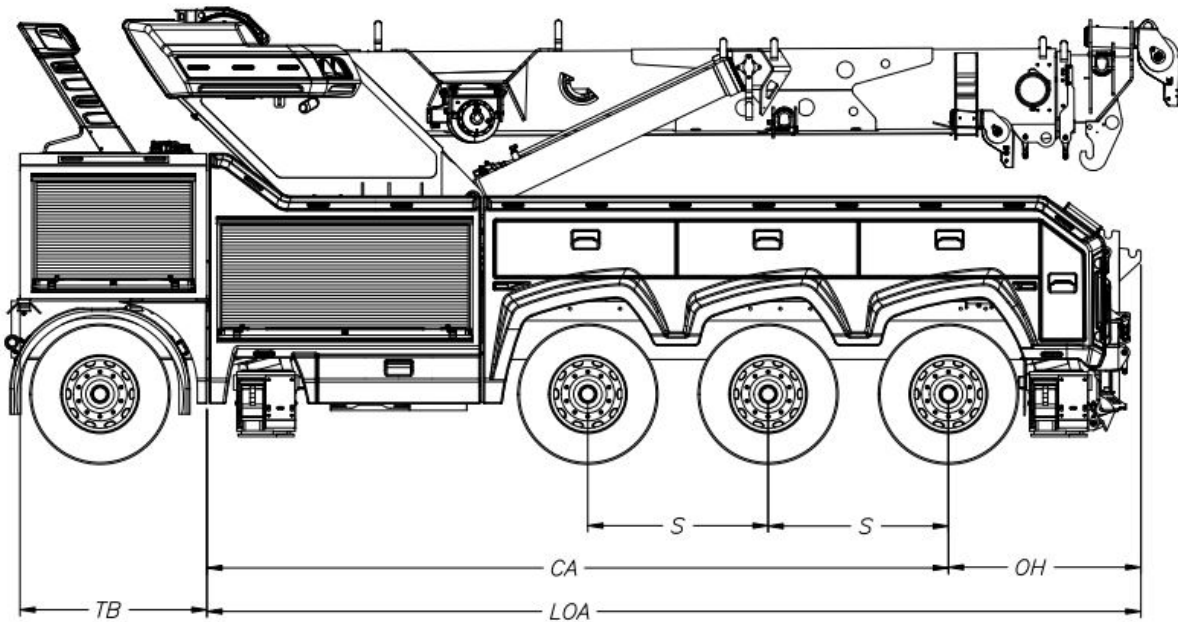

FIGURE 10 - CHASSIS DIMENSIONS - SIDE VIEW (CSR85 SHOWN)

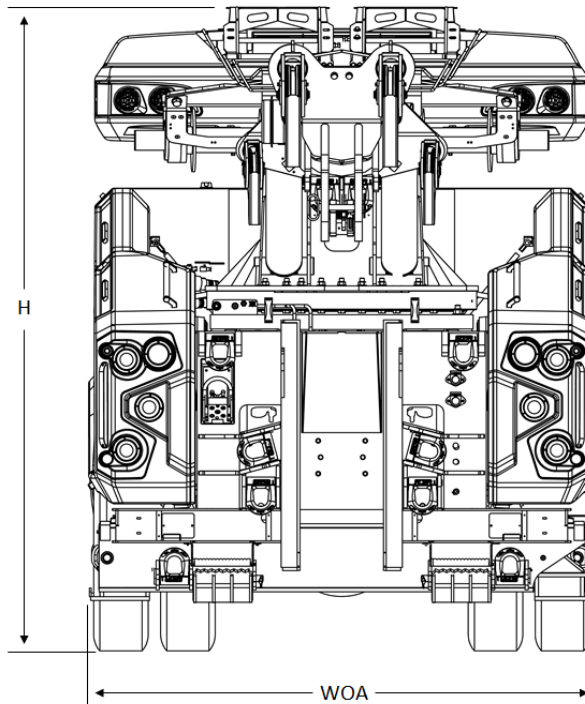

FIGURE 11 – CHASSIS DIMENSIONS - TOP VIEW (EXAMPLE)

TABLE 5 - CHASSIS DIMENSIONS (IN METRIC [IMPERIAL])

Dimension	CSR50	CSR65	CSR85
S	1,372 mm [54"]	1,372 mm [54"]	1,372 mm [54"]
CA (min)	5,029 mm [198"]	6,248 mm [246"]	7,137 mm [281"]
WOA	2,590 mm [102"]	2,590 mm [102"]	2,590 mm [102"]
LOA	6,325 mm [249"]	7,518 mm [296"]	7,087 mm [279"]
OH	1,397 mm [55"]	1,397 mm [55"]	1,473 mm [58"]
TB	711–1,830 mm [28–72"]	1,016–1,830 mm [40–72"]	1,422–1,830 mm [56"-72"]
H	3,150 mm [124"] *	3,277 mm [129"] *	3,454 mm [136"]*

\* For a 43-in. truck frame height

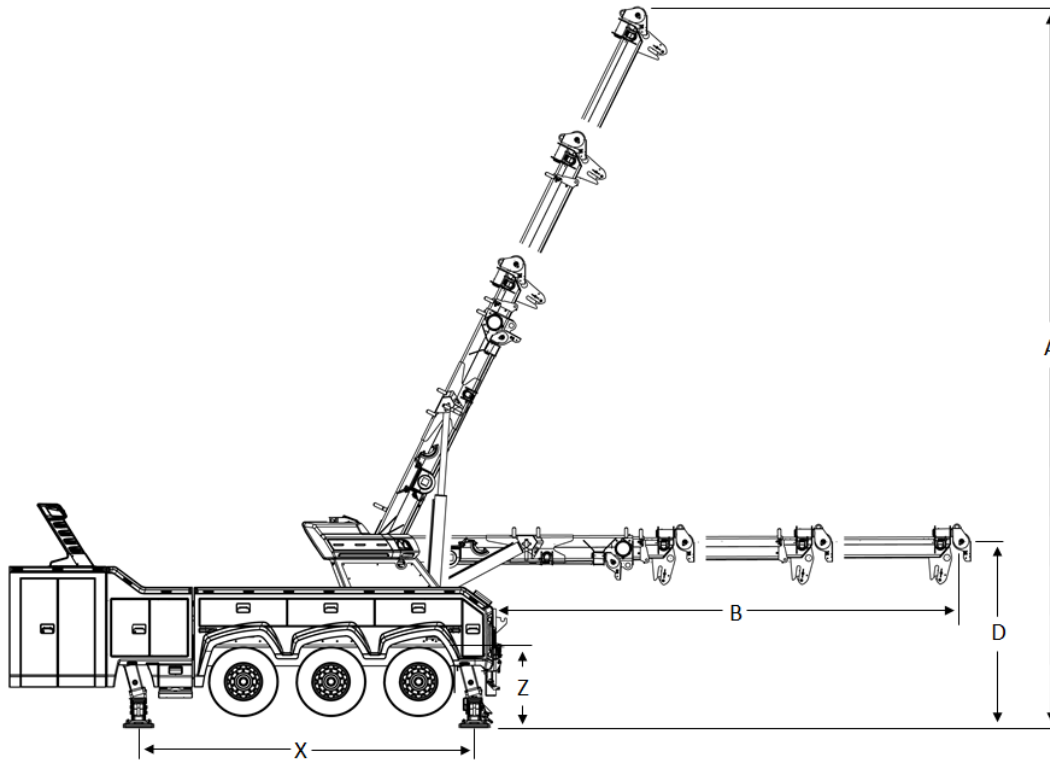

FIGURE 12 - BOOM AND OUTRIGGER DIMENSIONS - SIDE VIEW (EXAMPLE)

TABLE 6 - BOOM AND OUTRIGGER DIMENSIONS - SIDE VIEW (IN METRIC [IMPERIAL])

Dimension	CSR50 3-STAGE	CSR65 3-STAGE	CSR85
A	11.17 m [36' 8"]	13.48 m [44' 3"]	16.84 m [55' 3"]
B	7.42 m [24' 4"]	9.32 m [30' 7"]	11.86 m [38' 11"]
D	2.90 m [9' 6"]	3.15 m [10' 4"]	3.40 m [11' 2"]
X	5.28 m [17' 4"]	5.28 m [17' 4"]	5.99 m [19' 8"]
Z	1.41 m [55"]	1.41 m [55"]	1.42 m [56"]

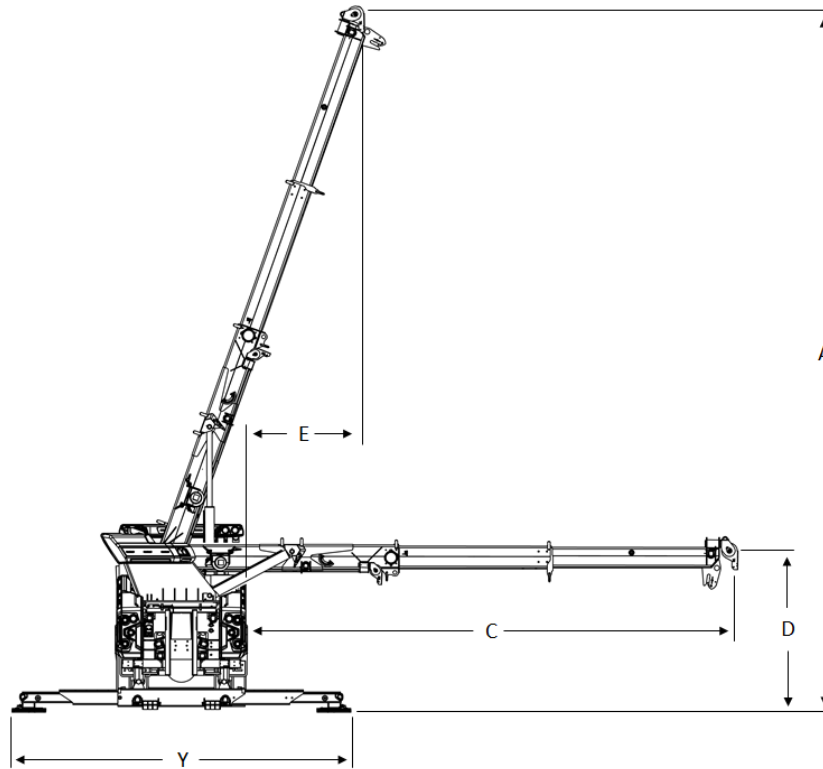

FIGURE 13 - BOOM AND OUTRIGGER DIMENSIONS - REAR VIEW (EXAMPLE)

TABLE 7 – BOOM AND OUTRIGGER DIMENSIONS - REAR VIEW (IN METRIC [IMPERIAL])

Dimension	CSR50 3-STAGE	CSR65 3-STAGE	CSR85 3-STAGE
A	11.17 m [36' 8"]	13.48 m [44' 3"]	16.84 m [55' 3"]
C	7.72 m [25' 4"]	9.60 m [31' 6"]	12.57 m [41' 3"]
E	2.62 m [8' 7"]	2.29 m [7' 6"]	3.05 m [10']
Y	5.39 m [17' 8"]	6.63 m [21' 9"]	7.11 m [23' 4"]

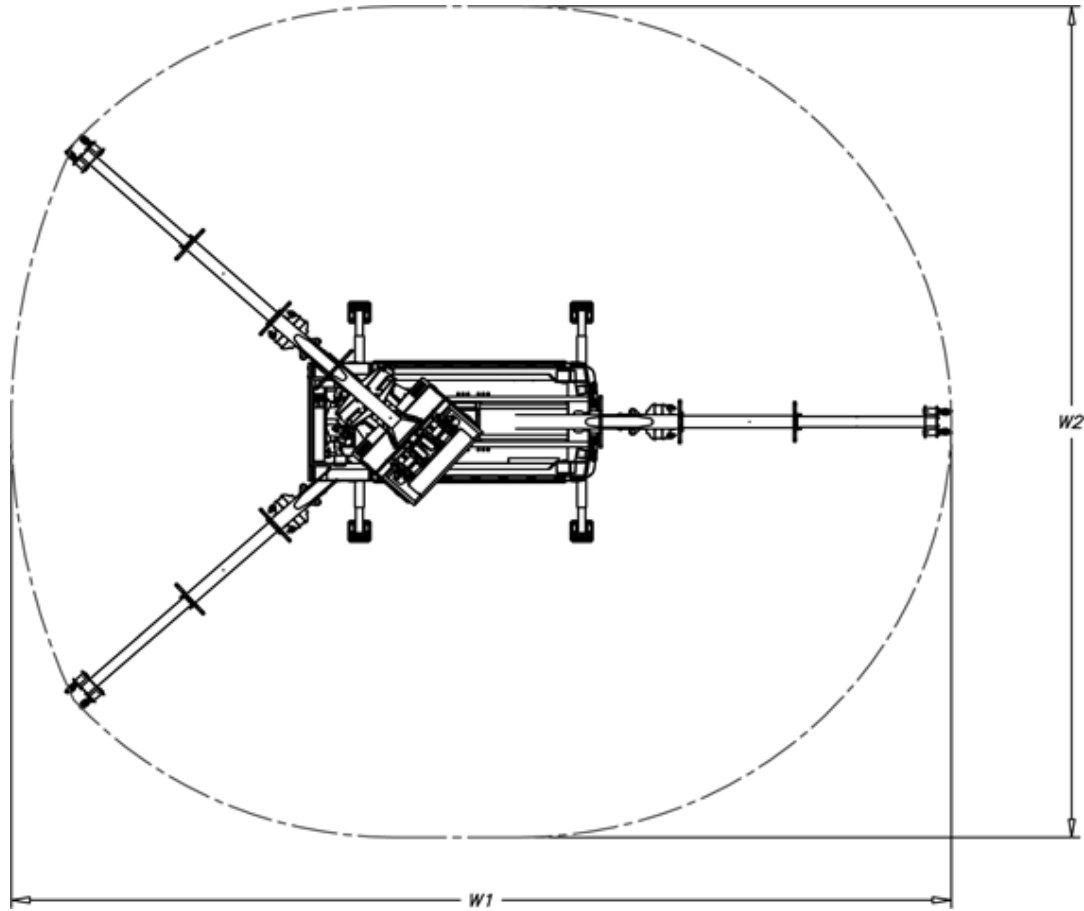

FIGURE 14 - WORKING AREA DIMENSIONS - TOP VIEW (EXAMPLE)

TABLE 8 - WORKING AREA DIMENSIONS - TOP VIEW (IN METRIC [IMPERIAL])

Dimension	CSR50 3-STAGE	CSR65 3-STAGE	CSR85 3-STAGE
W1	14.63 m [48']	21.67 m [71' 1"]	31.24 m [102' 6"]
W2	16.97 m [55' 8"]	20.82 m [68' 4"]	27.73 m [91' 0"]

**1.2.4 Hydraulic system**

**TABLE 9 - HYDRAULIC SYSTEM SPECIFICATIONS (IN METRIC [IMPERIAL])**

Element	CSR50	CSR65	CSR85
Hydraulic pump	Dual piston pump	Dual piston pump	Single pump with load-sensing
Working hydraulic pressure	207 bar [3,000 psi]	241.3 bar [3,500 psi]	260 bar [3,770 psi]
Slide cylinder stroke	2,794 mm [110"]	3,225 mm [127"]	3,530 mm [139"]
Boom lift cylinder	Dual Ø 165 mm [6 ½"]	Dual Ø 178 mm [7"]	Dual Ø 203 mm [8"]

## 1.2.5 Winches

The following tables list the various winches and cables available for each wrecker model, as well as their specifications.

**IMPORTANT:** NRC equipment uses winches of various brands and models. Always refer to the winch manufacturer manual for information specific to your winch.

### CAUTION

The rated line pulls shown are for the winch only. See the wire rope manufacturer for the wire rope specifications.

As recommended in SAE J959, the strength factor for live or running ropes that wind on drums or pass over sheaves shall be not less than 3.55.

As recommended in EN 14492-1 (ref. 5.15.6), the working coefficient for the first rope layer shall be at least 2.

The winch performance in high speed yields line speeds 2x those charted below, and yields line pulls 1/2x those charted below.

Always be sure that at least 5 full turns of steel winch cable, or 8 full turns of synthetic winch cable (black section of the cable) are wrapped around the winch drum. The friction provided by the wrapped cable allows the drum to pull on the winch cable and move the load.

TABLE 10 – WINCHES AVAILABLE FOR EACH WRECKER MODEL

	Main Winches			Auxiliary Winches			Drag Winch
Capacity kg [lb.]	18,143 [40,000]	22,679 [50,000]	27,215 [60,000]	6,803 [15,000]	9,071 [20,000]	11,339 [25,000]	22,679 [50,000]
Type	2-speed planetary			Planetary			
	Wire rope						
Length m [ft.]	61 [200]						91 [300]
Diameter mm [in.]	19 [.787]	22 [7/8]		14 [9/16]	16 [5/8]		19 [3/4]
	Winches available for each wrecker model						
CSR50	S	-	-	O	O	-	O
CSR65	-	S	-	-	O	-	O
CSR85	-	-	S	-	-	O	O
<i>S = standard, O = optional, - = not available</i>							

**TABLE 11 - WINCH SPECIFICATIONS OF THE CSR50 - 40,000 LB (IN METRIC [IMPERIAL])**

Element		Specification				
Winch capacity		177.9 kN [40,000 lb.]				
Wire rope						
Recommended		19 mm x 61 m [0.787" x 200'] EIPS cable				
Working load limit		7,512 kg [16,563 lb]				
Breaking load limit		26,308 kg [58,800 lb]				
Wire rope - EN 14492-1:2006						
Max rope diameter		20 mm				
Minimum rope breaking strength		355.8 kN [80,000 lb.]				
Layer of cable		1	2	3	4	5
Rated line pull per layer Low speed	kg lb.	18,100 [40,000]	15,100 [33,500]	13,000 [28,800]	11,400 [25,300]	10,200 [22,500]
Cable capacity	m ft.	7 [25]	16 [55]	28 [95]	41 [135]	56 [185]
Line speed (at 17 gpm/64.3 Lpm) Low speed	MPM FPM	4.8 [16]	5.6 [18.7]	6.3 [21]	7.2 [24]	8.2 [27]

**TABLE 12 - WINCH SPECIFICATIONS OF THE CSR65 - 50,000 LB. (IN METRIC [IMPERIAL])**

Element		Specification				
Winch capacity		222 kN [50,000 lb.]				
Wire rope - North America						
Recommended		22 mm x 61 m [7/8" x 200'] EIPS 1960 IWRC				
Working load limit		10,170 kg [22,420 lb.]				
Breaking load limit		36,105 kg [79,600 lb.]				
Wire rope - EN 14492-1:2006						
Max rope diameter		22 mm				
Minimum rope breaking strength		445 kN [100,000 lb.]				
Layer of cable		1	2	3	4	5
Rated line pull per layer Low speed <sup>1</sup>	kg lb	18,100 [50,000]	15,100 [41,400]	13,000 [35,300]	11,400 [30,700]	10,200 [27,200]
Cable capacity <sup>1</sup>	m ft	7 [25]	16 [55]	28 [95]	41 [135]	56 [185]
Line speed (at 17 GPM) Low speed <sup>1</sup>	MPM FPM	4.8 [16]	5.6 [18.7]	6.3 [21]	7.2 [24]	8.2 [27]

Note 1: Based on 22 mm [7/8"] wire rope.

**TABLE 13 - WINCH SPECIFICATIONS OF THE CSR85 - 60,000 LB. (IN METRIC [IMPERIAL])**

Element		Specification				
Winch capacity		266.8 kN [60,000 lb.] or 256.6 kN for EN 14492-1				
Wire rope						
Recommended		21 mm x 61 m [7/8" x 200'] EIPS 1960 IWRC				
Working load limit		10,170 kg [22,420 lb.]				
Breaking load limit		36,106 kg [79,600 lb.]				
Wire rope - EN 14492-1:2006						
Max rope diameter		23 mm				
Minimum rope breaking strength		513.2 kN [115,000 lb.]				
Layer of cable		1	2	3	4	5
Rated line pull per layer Low speed	kg lb	27,215 [60,000]	23,450 [51,700]	20,593 [45,400]	18,370 [40,500]	16,556 [36,500]
Cable capacity	m ft	10 [33]	21 [71]	35 [115]	50 [164]	66 [218]
Line speed (at 17 GPM) Low speed	MPM FPM	4.8 [16]	5.6 [18.7]	6.3 [21]	7.2 [24]	8.2 [27]

### 1.2.6 Underlift dimensions and capacity

NOTE: Underlift specifications are based on the static structural rating.

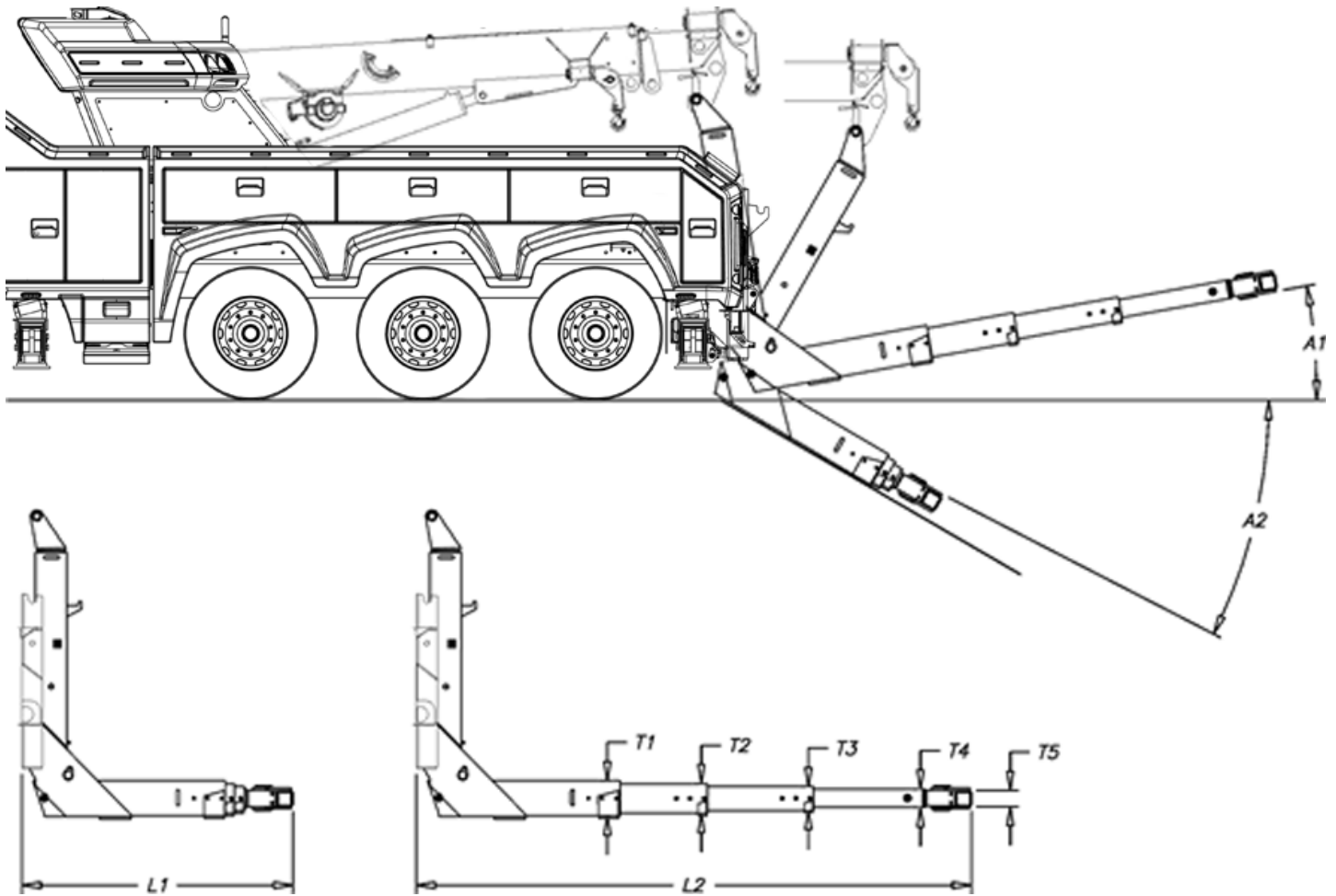

FIGURE 15 - UNDERLIFT DIMENSIONS (EXAMPLE)

TABLE 14 - UNDERLIFT DIMENSIONS AND CAPACITY (IN METRIC [IMPERIAL])

Dimension	HD-3	HDE-3	SHD-3	LSHDE-3	XSHDE-3	SSHD-4	LSHD-4
A1	8°	8°	9°	8°	8°	9°	9°
A2	14°	17°	11°	17°	17°	14°	14°
L1	1,784 mm [70.3"]	1,895 mm [74.6"]	2,089 mm [82.3"]	2,040 mm [80.3"]	2,222 mm [87.5"]	1,829 mm [72"]	2,100 mm [82.7"]
L2	2,759 mm [108.6"]	3,670 mm [144.5"]	3,340 mm [131.5"]	3,648 mm [143.6"]	4,210 mm [165.8"]	3,679 mm [144.8"]	4,323 mm [170.2"]
Reach (L2-L1)	975 mm [38.3"]	1,775 mm [69.9"]	1,251 mm [49.2"]	1,608 mm [63.3"]	1,988 mm [78.3"]	1,850 mm [72.8"]	2,223 mm [87.5"]
T1	203 mm [8"]	210 mm [8.3"]	254 mm [10"]	235 mm [9.3"]	235 mm [9.3"]	281 mm [11.1"]	281 mm [11.1"]
T2	153 mm [6"]	170 mm [6.7"]	203 mm [8"]	189 mm [7.4"]	189 mm [7.4"]	235 mm [9.3"]	235 mm [9.3"]
T3	127 mm [5"]	133 mm [5.3"]	152 mm [6"]	146 mm [5.8"]	146 mm [5.8"]	189 mm [7.4"]	189 mm [7.4"]
T4	N/A	N/A	N/A	N/A	N/A	146 [5.8"]	146 [5.8"]
T5	195 mm [7.7"]	135 mm [5.3"]	195 mm [7.7"]	135 mm [5.3"]	135 mm [5.3"]	195 mm [7.7"]	195 mm [7.7"]
Towing capacity	356 kN [80,000 lb]	356 kN [80,000 lb]	400 kN [90,000 lb]	400 kN [90,000 lb]	400 kN [90,000 lb]	356 kN [80,000 lb]	356 kN [80,000 lb]
Lifting capacity when extended	67 kN [15,000 lb]	71 kN [16,000 lb]	89 kN [20,000 lb]	89 kN [20,000 lb]	89 kN [20,000 lb]	102 kN [23,000 lb]	89 kN [20,000 lb]

Dimension	HD-3	HDE-3	SHD-3	LSHDE-3	XSHDE-3	SSHD-4	LSHD-4
Lifting capacity when retracted	156 kN [35,000 lb]	156 kN [35,000 lb]	222 kN [50,000 lb]	222 kN [50,000 lb]	222 kN [50,000 lb]	311 kN [70,000 lb]	267 kN [60,000 lb]

### 1.2.7 Lifting capacity

To understand your model's lifting capacities, see the charts that were delivered with your wrecker or the Job Planner and Operation sections in the V1200.

## 2 SAFETY

### 2.1 General

#### **⚠ DANGER**

**Safety must be your top priority when operating and maintaining this equipment. Improper use of this equipment is dangerous. Failure to comply with the safety guidelines in this manual can cause accidents that may result in material damage, injury or even death.**

Should you find that this manual contains insufficient or unclear information about equipment operation and maintenance, please contact your nearest NRC distributor for more details (see the Authorized distributors and service providers section).

### 2.2 Safety labels

Ensure that all DANGER, WARNING, CAUTION and other labels and lifting capacity charts are legible and properly placed. Clean and replace them as needed.

### 2.3 Intended use

NRC Industries equipment is intended for use only by trained and qualified operators who have carefully read and understood the contents of this manual.

This product was designed to recover and tow vehicles that do not exceed its lift or tow ratings.

This manual explains how to properly use the towing equipment. However, you should also refer to the towing recommendations from the vehicle manufacturer or a certified towing manual to learn about recovery procedures for the vehicle to be towed.

#### **⚠ DANGER**

**This equipment was not designed for lifting persons and must never be used for that purpose.**

## 2.4 NRC responsibilities

**IMPORTANT:** NRC Industries Inc. rejects any claim that may result from the incorrect or unlawful application of its equipment.

NRC recommends that the wrecker mounting plates be inspected every three months by an authorized NRC distributor. Should a visual inspection identify any cracks or structural damage, immediately discontinue use until the equipment is deemed safe.

NRC recommends that the hydraulic system of the wrecker be checked at least once a year, **ONLY** by an authorized NRC distributor.

Wreckers must not be modified without prior authorization from NRC Industries. Any unauthorized modifications may void the warranty.

## 2.5 Supervisory responsibilities

A full understanding of this manual is essential to safely operate and maintain this equipment. Ensure that all operators carefully read and understand this manual before allowing them to operate or maintain the equipment or any of its parts. Once operators have read and understood the manual, have them sign the Operator record at the end of this manual.

A PIN code issued by NRC Industries is needed to access certain factory settings in the electronic control system. Give the PIN code for unlocking the console **ONLY** to trained personnel who understand the importance of not modifying the settings, since they can affect equipment operation.

Equipment manufactured by NRC Industries is intended for use by towing and recovery professionals, and not unqualified or untrained individuals. The equipment should not be loaned or rented to anyone lacking the required skills.

NRC recommends fitting **ALL** tow trucks with beacons or other lights to signal their presence and comply with local regulations.

## 2.6 Operator responsibilities

Read and understand this manual before attempting to operate or maintain your equipment. Read all the warning labels and exercise good judgment and common sense while using the equipment.

Never operate this equipment under the influence of drugs or alcohol.

**EMERGENCIES:** Use the emergency stop to immediately stop the machine.

### 2.6.1 Wear protective clothing

Always wear protective gloves.

Wear a hard hat and safety footwear when walking on the wrecker deck.

Wear long sleeves, bright-coloured clothing with reflective strips, work gloves, and safety boots.

Wear safety goggles.



### 2.6.2 Follow safety rules

Before driving the vehicle, check that the power take-off (PTO) is disengaged:

- The control levers should no longer be functional.
- The warning light in the cab should be off.

Never tow a vehicle that has people inside.

Never exceed equipment or chassis ratings. This could cause injury and/or damage the equipment.

Always use safety chains when towing and lifting.

Only suspend loads from the boom/winch cables. Applying a load to the vehicle by another means is strictly prohibited. Any lateral or vertical force applied to the boom may damage the vehicle and injure the operator.

If the equipment controls are too near traffic or a potential hazard, use the remote control and keep your distance.

When operating the vehicle on the roadside or in any dangerous area, select the controls situated away from the danger or traffic to ensure maximum safety.

When the vehicle is not in use, ensure that the PTO is disengaged.

Inspect the cables regularly and replace any worn or damaged ones.

### 2.6.3 Avoid danger zones

The area underneath the rotating lifting device is a DANGER ZONE and must never be entered.

To avoid getting wrapped or tangled, keep away from the places where:

- The winch cables pass through the fairlead at the end of the boom.
- The winch cables wind onto the boom.

Always keep clear of winches and cables. Although the relatively low speed of the winches will keep any risks to a minimum, stay away from cables at all times — regardless of whether they are moving or stationary, taut or loose. Never step over a cable or chain, whether it is taut or not.

### 2.6.4 Set up a safety perimeter

Always set up a safety perimeter at least 45 m (150') in diameter around the equipment and any load or vehicle. Do not allow anyone to enter this danger zone when you are using the equipment.

In addition, do not allow anyone within 75 m (250') of a winch cable.

## 2.7 Conditions for use

### 2.7.1 Risk of electric shock

The wrecker is not insulated and offers no protection against electric currents.

- Never operate the wrecker in places where power lines, underground cables or other energy sources may exist unless the power company has turned off the power. If working in the dark, use adequate lighting to look for power lines.
- Always check for power lines before using the boom and ensure that it does not come into contact with power lines.
- Keep a safe distance away from the power lines.
- Do not touch or get out of an energized vehicle.
- Avoid raising the boom during a thunderstorm, since it could attract lightning.

- Maintain at least 3 m (10') of clearance between all wrecker parts and power lines or devices with more than 50,000 volts. See the minimum approach distances in the table and add an additional 30 cm (1') for every 30,000 volts or portion thereof.

Minimum approach distance (M.A.D.)	
Voltage range (phases to phase) (kV)	Minimum approach distance
0-50	10 ft [3 m]
>50-200	15 ft [5 m]
>200-350	20 ft [6 m]
>350-500	25 ft [8 m]
>500-750	35 ft [11 m]
>750-1,000	45 ft [14 m]

**NOTE:** This requirement shall apply except where employer, local or government regulations are more stringent.

- The minimum approach distance can be reduced if insulating barriers are installed and are rated for the power line in question. These barriers must not be part of (or attached to) the wrecker. The minimum approach distance must be reduced based on the dimensions provided by the insulating barrier design. The reduced distance must be calculated by a qualified individual in compliance with employer, local, regional or national requirements for work near electrical equipment.

## **⚠ DANGER**

**All persons and wrecker parts must remain at the minimum approach distance from energized power lines or equipment. When in doubt, always assume that the power line or equipment is energized.**

### **2.7.2 Hazardous winds**

Never do any lifting when winds put personnel, the public or property at risk. Evaluate the size and shape of the load to determine whether the wind could cause problems. For example, even though the load weight may be within capacity, heavy winds and gusts can catch any large surfaces and cause them to twist or become out of control during lifting. Swinging and spinning loads pose a risk to the rigging and may potentially overload the lifting equipment.

### **2.7.3 Slipping and tipping hazards**

Place the wrecker on a stable and level surface.

If the ground is not level, level the truck.

Use extra caution when operating the wrecker on icy surfaces. Use the outriggers and spades to prevent the wrecker from slipping.

### **2.7.4 Obstacle clearance distance**

Keep all loads a safe distance away from surrounding obstacles.



## 3 OPERATION

This chapter describes how to operate your wrecker, which involves using many functions and components simultaneously. To take advantage of all the capabilities of your wrecker, you must first understand the general operating principles.

### 3.1 Operating principles

#### **! DANGER**

**Your wrecker is a powerful machine. Always think about what you are about to do before operating the equipment and ensure that you apply general vehicle equilibrium and stability principles as described in this section. For lifting capacities, see 1.2.7 Lifting capacity. Lifting a load that exceeds the specified lifting capacities can damage the equipment or cause it to tip over.**

**FAILURE TO FOLLOW THESE INSTRUCTIONS CAN RESULT IN THE EQUIPMENT TIPPING OVER, WHICH CAN CAUSE PROPERTY DAMAGE, INJURIES OR EVEN DEATH.**

The general principles to understand before operating the machine are as follows:

1. The more you extend the boom, the less weight you will be able to lift with it.
2. You can lift more weight from the rear of the wrecker than from the side.
3. Lifting from the side of the wrecker works best over the front outriggers.

#### 3.1.1 Distributing the wrecker weight

The distribution of the wrecker weight over the front and rear outriggers can be adjusted by lowering/raising the front outriggers. The shape of the steer tires can be used to estimate the load carried by the front outriggers.

- If the front wheels are barely off the ground and the sidewall shows evidence of a loaded tire, there will be less ground pressure on the front outriggers and more on the rear outriggers. This situation is optimal for lifting in the rear area.

- If the front wheels are completely lifted off the ground, more load will be shifted from the rear to the front outriggers. There will be more ground pressure on the front outriggers and less on the rear outriggers. This situation is ideal for lifting off the side in the midship area of the vehicle.

Any configuration between the two mentioned above will provide intermediate stability characteristics.

For most situations, NRC recommends that the steer tires are left on the ground with moderate ground pressure.

## **! DANGER**

**Ensure that ONLY the outrigger feet touch the ground. If any other outrigger parts touch the ground, the wrecker will become unstable.**

**Ensure that you are constantly monitoring the outriggers and that they all stay in contact with the ground at all times.**

**Should any of the outriggers start to leave the ground, or show an imminent risk of floating, immediately stop all lifting or winching operations to avoid any risk of tipping over. Any suspended load should be lowered by retracting the boom or winching down. DO NOT LOWER THE BOOM as it would move the load away from the vehicle, increasing the overturning moment and the risk of tipping over.**

**Before beginning lifting or winching operations again, the operator must ensure that:**

- **The ground and blocking are sound and show no risk of sinking or collapsing.**
- **The load has been reduced or re-rigged to reduce overturning moment.**
- **The outriggers system has been reconfigured to optimize load distribution on the outrigger system: more ground pressure is needed on the previously floating outrigger pad.**

**FAILURE TO FOLLOW THESE INSTRUCTIONS CAN RESULT IN THE WRECKER TIPPING OVER, WHICH CAN CAUSE PROPERTY DAMAGE, INJURIES OR EVEN DEATH.**

### 3.1.2 Lifting from the rear of the wrecker

The best point for lifting is from the rear of the wrecker, as you will benefit from the full counterweight effect. The weight of the wrecker will be spread over the full length of the chassis, sometimes over 11 m (35').

### 3.1.3 Lifting from the side of the wrecker

You will not be able to lift as much from the side of the wrecker, since the counterweight is calculated from the centre of gravity to the ends of the outriggers. Understanding the counterweight effect is very important, since it can be adjusted and used to your advantage.

Because the front outriggers are normally located very close to the vehicle's centre of gravity, that is where you will be able to pick up the most weight from the side. To lift a load from the side, it is best to slide the crane above the front outriggers, putting the maximum possible weight on the front outriggers. First, lift the rear axles completely off the ground, and then lift the front axle just enough to get it off the ground.

**IMPORTANT:** If you do not put the maximum possible weight on the front outriggers, you will **not** be able to lift the maximum load in this position.

If all the weight is on the front outriggers and you want to slide and rotate the load, the rear outriggers may start to leave the ground when the crane is level with the rear outriggers (its weakest point). If this happens:

- Carefully put down the load.
- Redistribute the vehicle weight by transferring some to the rear by lowering the front axle of the vehicle to the ground.

### 3.1.4 Using the wrecker for the first time

When using the wrecker for the first time, we recommend that you lower the outriggers until the rear axles are completely off-loaded and slightly above the ground, and the front axles are mostly off-loaded but still on the ground. This setup should provide good all-around performance for various lifting scenarios. Do this until you are comfortable with the counterweight effect.

### 3.1.5 Maximizing the pulling capacity of the winch

**IMPORTANT:** Make sure to keep at least 5 turns of cable on the winch drum for steel cable, or 8 turns for synthetic cable.

**NOTE:** See Section 1.2.5 Winches or the manual provided by the winch manufacturer for information about pulling force versus the number of layers of cable remaining on the drum.

### 3.1.6 Increasing winch capacity with pulleys

If you need to pull a load that exceeds the safe working limit of the wire or synthetic rope, you can reduce line tension and increase pulling capacity using blocks. Use a running block tackle and an anchor to pull the load as shown in Figure 16 to double the pulling force. You need to factor in veer angle and friction loss in the blocks, which can be up to 10% for poorly-maintained/lubricated blocks.

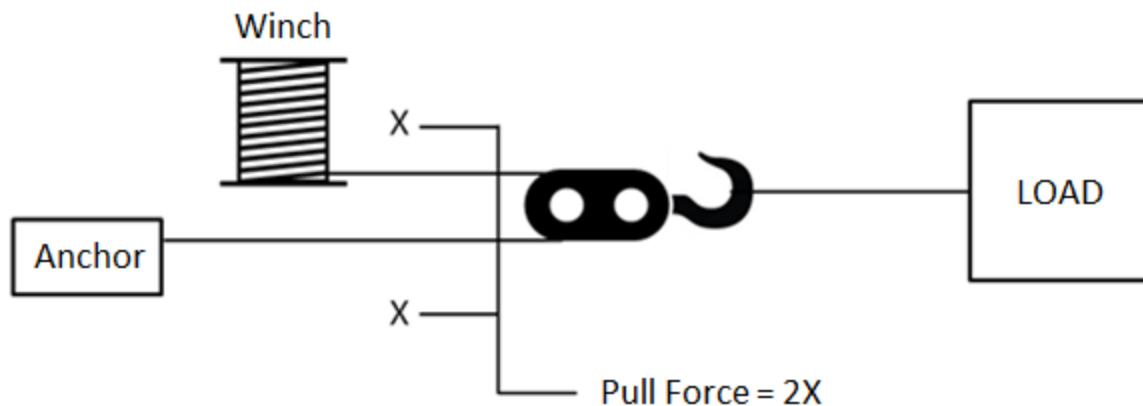

FIGURE 16 – CALCULATING INCREASED WINCH CAPACITY

You can calculate the total winch-pulley-anchor capacity using this formula:

Winch-pulley-anchor pull force = 90% of  $(2 \times X)$

Where X = winch capacity

For X = 20,000 lb.

Total pull force = 90% of  $(2 \times 20,000 \text{ lb.}) = 36,000 \text{ lb.}$

## 3.2 Preparing the wrecker for optimal performance

Position the wrecker on a flat, solid surface with the rear as close as possible to the load. Ensure that you have sufficient reach and lifting capacity to safely proceed (see Section 1.2.7 Lifting capacity).

If the load weight is close to the capacity of your wrecker, you can move the load and wrecker closer by removing the underlift from the wrecker chassis (see Section 3.8.5 Removing the underlift from the wrecker). Moving the wrecker closer to the load increases the boom's lifting capacity.

Lifting a heavy load places significant weight on each outrigger. Ensure that the ground is solid enough to prevent the outriggers from sinking.

### DANGER

**Risk of tipping the wrecker. Ensure that ONLY the outrigger feet touch the ground. If any other outrigger parts touch the ground, the wrecker will be unstable.**

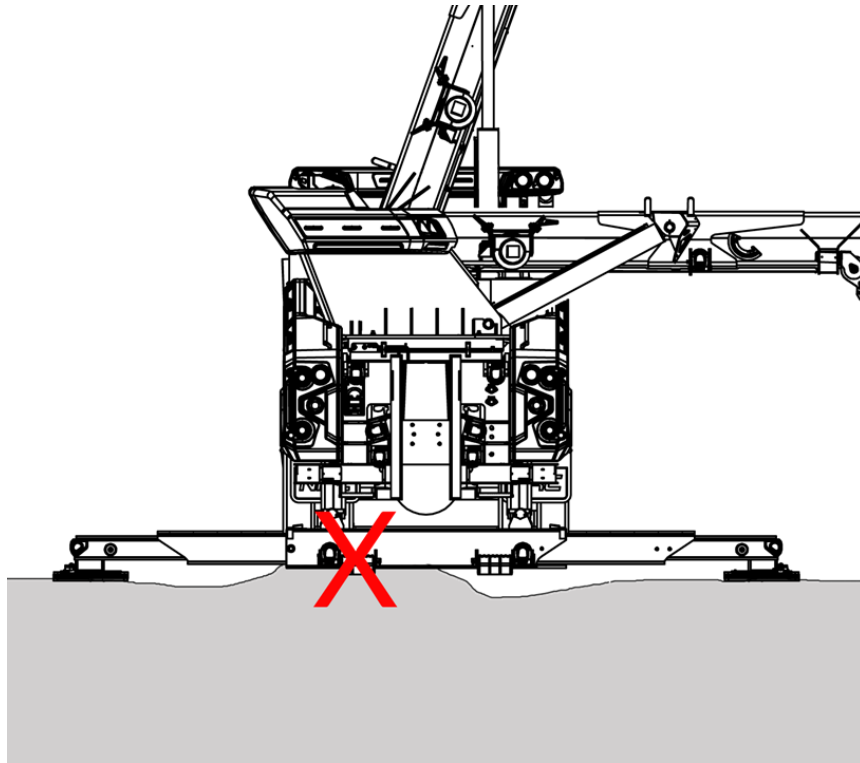

FIGURE 17 – OUTRIGGERS TOUCHING THE GROUND (EXAMPLE)

Decide whether to keep the underlift in place or remove it from the wrecker chassis and put it on the ground. The boom has a limited field of movement when the underlift is attached. The boom's hydraulic lift cylinders may come into contact with the top of the underlift stinger when it is lowered and slid to the rear of the chassis. To learn how to remove the underlift, see Section 3.8.4 Attaching the underlift to the boom.

## NOTICE

**Exercise caution when using the wrecker with the underlift, since any contact between the boom and underlift can damage the equipment.**

### 3.3 Safety guidelines

Before operating the underlift, boom or winches, ensure that:

- You fully understand all the safety rules in Chapter 2 Safety.
- You are familiar with the wrecker and you have positioned it for optimal and safe operation (see Section 3.4 Familiarizing yourself with the equipment).
- The truck is properly levelled and stabilized (see Sections 3.7.1 Stabilizing the wrecker using the outriggers and 3.7.2 Levelling the wrecker).

After levelling and stabilizing the truck and before operating the underlift, boom or winches, always ensure that:

- The auto-levelling system is deactivated.
- The anti-twist system is deactivated.

If the anti-twist system wrecker-twisted indicator lights up, indicating that the wrecker is twisted, immediately stop working. Examine the vehicle body to find out why it is twisted. To correct the issue, you may have to put the load down temporarily to move the truck into a more level and stable position.

Supervise the wrecker at all times during operation to ensure that it remains stable.

If you ever need to immediately stop all operations, press the emergency stop button. One is located on each control panel.

**NOTE:** Before restarting the engine, pull the emergency stop button.

## 3.4 Familiarizing yourself with the equipment

Before using the equipment, open the control panels and examine the controls and their layout. The controls are proportional, which means that the further the control levers are moved, the more the control speed increases. Proportional controls allow you to use very slow speeds for greater precision and maximum control of the load.

After familiarizing yourself with the equipment, we recommend running the engine at low speed (600–850 rpm).

### 3.5 Emergency hydraulic bypass

If you have trouble with the control panel on the left-hand side, you can use the manual override control panel in the centre toolbox on the left-hand side. To use the hydraulic levers, remove the protective cover over the levers. Another manual override control panel is inside the sliding rotator base for the boom and winch levers.

The PTO must be engaged in order to use the emergency hydraulic bypass.

**IMPORTANT:** Never store any tools or other items inside the protective cover. The hydraulic levers move when their corresponding electronic levers are activated, and any tools or other items inside could restrict the movement of the levers.

## NOTICE

**With the emergency hydraulic bypass, the boom can be rotated over the cab without any limitations or electronic surveillance. Ensure that the boom and load always remain at a safe distance from the cab, as nothing will prevent them from hitting the cab.**

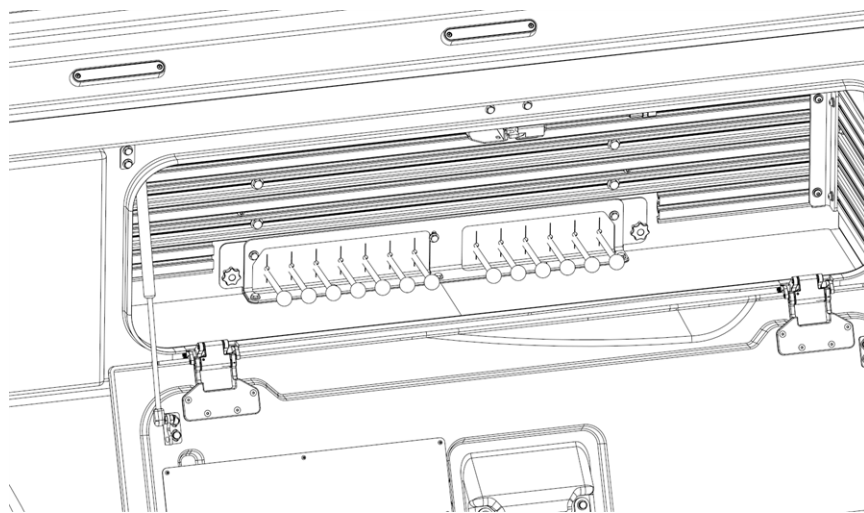

**FIGURE 18 – EMERGENCY HYDRAULIC BYPASS CONTROL PANEL**

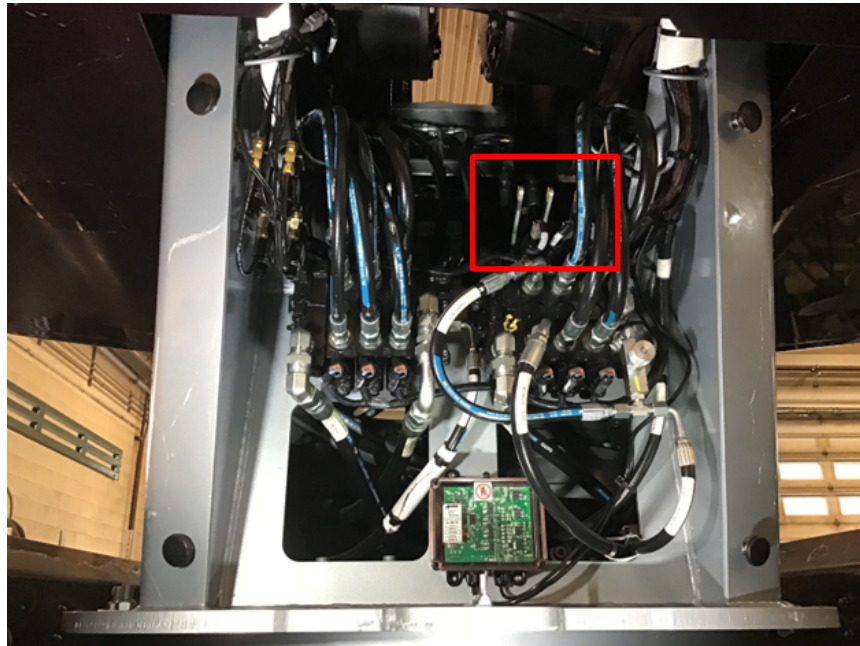

**FIGURE 19 – EMERGENCY HYDRAULIC BYPASS IN THE SLIDING ROTATOR BASE**

## 3.6 Common operating procedures

This section explains procedures for starting the engine, arriving at the job site, and leaving the job site.

### 3.6.1 Engaging the power take-off

Engaging the power take-off (PTO) activates the hydraulic pump, which supplies power to the controls. When the PTO is engaged, a warning light in the cab warns you that driving the vehicle may result in damage. Before driving the wrecker, ensure that the warning light is off and the PTO is disengaged.

The following is a general procedure for a manual transmission. An automated transmission or fully automatic transmission might require a different sequence to engage properly. Refer to the transmission and PTO operation manuals specific to your vehicle.

## WARNING

Turn off the wrecker engine and disengage the PTO when the wrecker is not in use.

## DANGER

The area under the lifting unit is **DANGEROUS**. Stay as far away as possible from the danger zone while the machine is operating.

To engage the PTO:

1. Check that none of the emergency stop buttons have been pressed and pull them, if necessary.
2. Ensure that the PTO is disengaged.
3. Start the truck engine.
4. Ensure that air pressure is above 70 psi before engaging the PTO.
5. Press the clutch, engage the PTO and release the clutch to start the hydraulic system. The hydraulic system supplies power to the boom, underlift, winch, etc.

The control panels automatically turn ON when you engage the PTO.

### 3.6.2 Upon arrival at the job site

Before operating the wrecker on a job site:

1. Position the wrecker for optimal and safe operation (see Section 3.2 Preparing the wrecker for optimal performance).
2. Stabilize the wrecker (see Section 3.7.1 Stabilizing the wrecker using the outriggers).
3. Level the wrecker (see Section 3.7.2 Levelling the wrecker).
4. Unhook the underlift from the boom (see Section 3.8.3 Unhooking the underlift from the boom) or remove the underlift from the wrecker body (see Section 3.8.5 Removing the underlift from the wrecker).

### 3.6.3 Before leaving the job site

After the job is finished, store the boom and underlift and prepare the wrecker for safe travel:

- Attach the underlift to the boom (see Section 3.8.4 Attaching the underlift to the boom).
- Lock the boom in storage position (see Section 3.9.4 Locking the boom in storage position).
- Lock the winches in storage position (see Section 3.10.4 Locking the winches in storage position).

## 3.7 Using the outriggers

The following sections explain how to use the outriggers to stabilize the wrecker, how to level the wrecker, and how to store the outriggers after the job is finished.

### 3.7.1 Stabilizing the wrecker using the outriggers

Following the principle of vehicle equilibrium described in Section 3.1 Operating principles, use the following principles and steps to stabilize and level the wrecker.

#### **⚠ CAUTION**

To avoid hitting a person or object, make sure you can see the outriggers when extending or lowering them.

#### **⚠ DANGER**

Ensure that **ONLY** the outrigger feet touch the ground. If any other outrigger parts touch the ground, the wrecker will be unstable. If this occurs, move the vehicle to more level ground and try again.

The general principles to understand before stabilizing the wrecker using the outriggers are as follows:

1. Always use controls located of the same side as the outrigger being operated. Extend each outrigger using proper control station. If this is not possible, ask help from a signaler or flagperson.
2. Inspect surface for each outrigger before lowering it and make sure the surface will be stable.

Following the principles above, stabilize the wrecker as follows:

1. Put a wood pad under each of the four outriggers. Lock them in place using a locking pin.

**NOTE:** The wood pads are stored in the toolboxes on each side of the wrecker. Hold the wood pad by its pin to install it more easily.

2. Using the proper control levers on the same side of the outrigger being moved, extend each front outrigger and lower it until the wrecker is light but not off the ground.

## **⚠ CAUTION**

**To avoid hitting a person or object, make sure you can see the outriggers when extending or lowering them.**

3. Using the proper control levers on the same side of the outrigger being moved, extend each rear outrigger and lower it just enough so that both rear axle wheels are off the ground.

### **3.7.2 Levelling the wrecker**

1. Level the wrecker along the front-rear axis using the outrigger control levers and a level.
2. Use the touchscreen interface to activate the anti-twist system.

## **NOTICE**

**This step is very important, as it untwists and significantly reduces the risk of damaging the body.**

3. Use the touchscreen interface to activate the auto-levelling system. This enables the wrecker to level itself. While this happens, the emergency hydraulic bypass control levers move automatically.
4. When the auto-levelling and the anti-twist systems are done, use the touchscreen interface to deactivate both systems.

### 3.7.3 Storing the outriggers

Once the job is complete, you need to store the outriggers in their storage position.

1. Use the touchscreen interface to set the outriggers to move vertically.
2. Using the levers on the left-hand side, fully raise all four outriggers simultaneously.
3. Remove the locking pins that hold the wood pads on each outrigger. Remove the wood pads and put the locking pins back in place. Store the wood pads in the toolboxes on each side of the wrecker.
4. Use the touchscreen interface to set the outriggers to move horizontally.
5. Using the levers on the left-hand side, fully retract all four outriggers simultaneously.

## 3.8 Using the underlift

The underlift is used to tow another vehicle.

For safety purposes, the underlift must be hooked to the boom for transportation.

The following sections describe all underlift operations.

### CAUTION

**Do not drive the wrecker while the underlift is in the storage position (resting on the storage pin).**

### 3.8.1 Understanding the underlift movements

The underlift is attached to and supported from above by the boom. The underlift also has two attached rollers, one on each side, that roll inside the rails of the wrecker. The rollers act as the underlift's fulcrum. Move the underlift and stinger by moving the boom as follows:

- Extend the boom to tilt the underlift stinger toward the ground. This will position the stinger under the vehicle to be towed.
- Retract the boom to tilt the underlift stinger away from the ground. This will lift the vehicle to be towed.
- Raise the boom to raise the whole underlift. This will raise the vehicle that you are towing.
- Lower the boom to lower the whole underlift. This will lower the vehicle that you are towing.

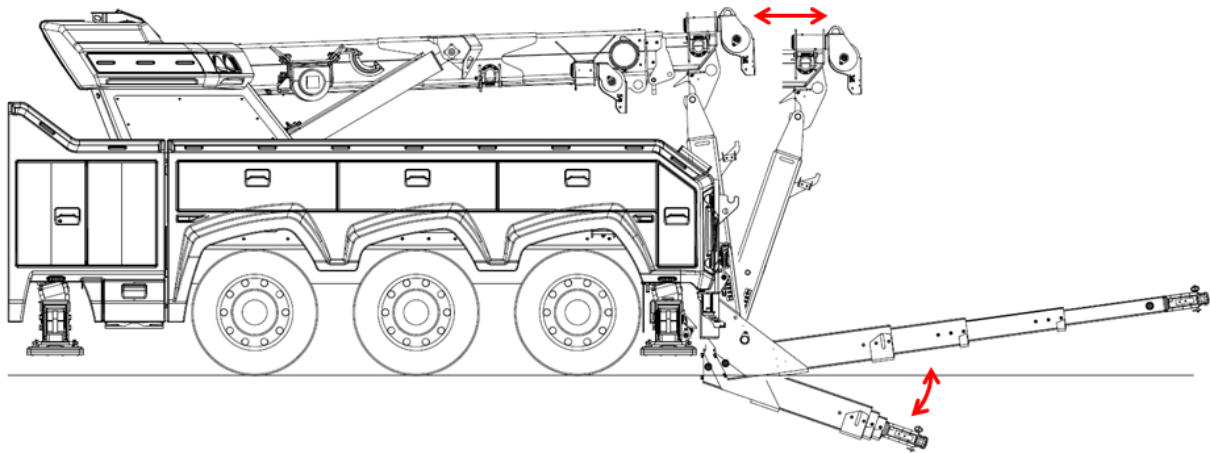

FIGURE 20 – UNDERLIFT MOVEMENTS

### 3.8.2 Towing another vehicle

## ⚠ CAUTION

If using the NRC Heavy duty tire lifts (bus brackets), use caution when installing them onto the T-bar to prevent injury. Position yourself correctly while lifting heavy objects.

1. Attach the underlift to the boom (see Section 3.8.4 Attaching the underlift to the boom).

## NOTICE

**Never use the underlift while it is in the storage position (resting on the storage pin).**

2. Disengage all winches (see Section 3.10.2 Disengaging and engaging the winches).

## NOTICE

**This prevents damage to the winches and cables when extending the boom.**

3. Extend the underlift stinger a few inches to allow it to clear its retaining clamp.
4. Unfold the underlift stinger completely using the corresponding lever on the control panel.
5. Lower the underlift, adjust the angle and extend the stinger using the corresponding controls to position the underlift beneath the vehicle to be towed.

**NOTE:** The boom is attached to the underlift, so they move together.

6. Choose a lifting point on the vehicle to be towed. It must be both strong enough and have enough clearance for the underlift stinger to move.

## DANGER

**Using a poor lifting point can cause severe damage to the towed vehicle and the wrecker, or even result in a serious accident.**

7. If needed, back up the wrecker closer to the vehicle to be towed to enable the underlift stinger to reach the chosen lifting point.

**NOTE:** If your wrecker is equipped with a remote control, you can use it to operate the underlift stinger. Alternatively, use the control panel levers.

8. Select the towing accessories or tools compatible with the chosen lifting point and position them on the T-bar.
9. Position the towing accessories under the lifting points using the underlift extension control.

## **! DANGER**

**Always use safety wheel stands when working under a towed vehicle. This will reduce the risk of a towed vehicle falling if the underlift system or its ancillary equipment fail. Failure to do so may lead to serious injury or even death.**

10. Attach and secure the vehicle to be towed to the towing accessories.
11. Lift the vehicle to be towed. For clearance and a height that is safe and complies with regulations, adjust the underlift stinger to the desired height.
12. Fully retract the underlift stinger, leaving enough clearance for a 70-degree turn. The more you retract the stinger, the less weight is transferred from the front axle to the rear axle, increasing vehicle control and manoeuvrability.

## **NOTICE**

**Always leave enough clearance for a 70-degree turn. Failure to leave enough space may result in severe damage to the towed vehicle and the wrecker.**

13. Disengage the winches (see Section 3.10.2 Disengaging and engaging the winches) and attach the cables to a suitable point on the underlift. Engage the winches and tighten the cable to prevent movement. Overtightening the cables can damage the cables, winches, boom or underlift.

14. Install the safety chains in the chain boxes on the rear bumper of the wrecker. Attach them to a solid anchor point on the vehicle to be towed to connect it to the T-bar and wrecker.
15. Prepare the vehicle to be towed.
  - a. Install the tow lights.
  - b. Connect the air supply and brake control. Test the brake.
  - c. Remove and secure the drive shaft(s) of any drive axles on the ground as per the recommendations from the towed vehicle manufacturer.

**NOTE:** For more detailed information on recovery and towing procedures for the vehicle to be towed, see the owner's manual of the vehicle to be towed.

The wrecker is now ready to tow the vehicle using the underlift. See Section 3.6.3 Before leaving the job site.

### 3.8.3 Unhooking the underlift from the boom

1. Disengage all winches (see Section 3.10.2 Disengaging and engaging the winches).

## NOTICE

**This will prevent damage to the winch cables.**

2. Slowly lift the underlift with the boom, just enough for the storage pin to slide into the pin hole in the underlift (see Figure 21).

**NOTE:** Storage pins are normally located in the rear toolboxes.



**FIGURE 21 – INSERTING THE UNDERLIFT STORAGE PIN (EXAMPLE)**

3. Slide the storage pin into the pin hole.

4. If your wrecker is equipped with the **manual safety attachment**:
  - a. Unlock the underlift safety attachment on the boom.

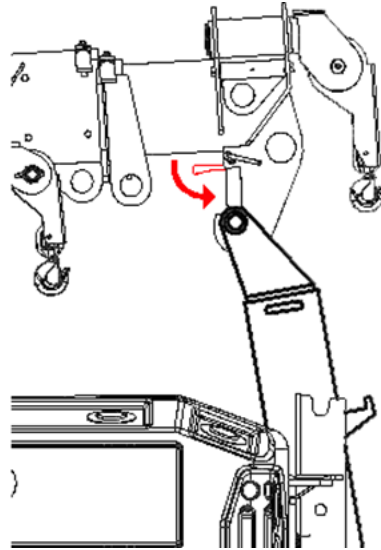

FIGURE 22 – UNLOCKING THE SAFETY ATTACHMENT (EXAMPLE)

- b. Slowly lower the boom so that the weight of the underlift is supported by the storage pin.

## NOTICE

**Ensure that the safety attachment is unlocked before lowering the boom. This prevents potential damage to the boom and underlift.**

- c. Lower the boom just enough to allow the boom head hooks to pass under the hinge pin at the top of the underlift.
    - d. Extend the boom so that the underlift is completely detached and supported by the storage pin.

5. **Or**, If your wrecker is equipped with the **automatic safety attachment**:
  - a. Remove the underlift safety pin from the boom.

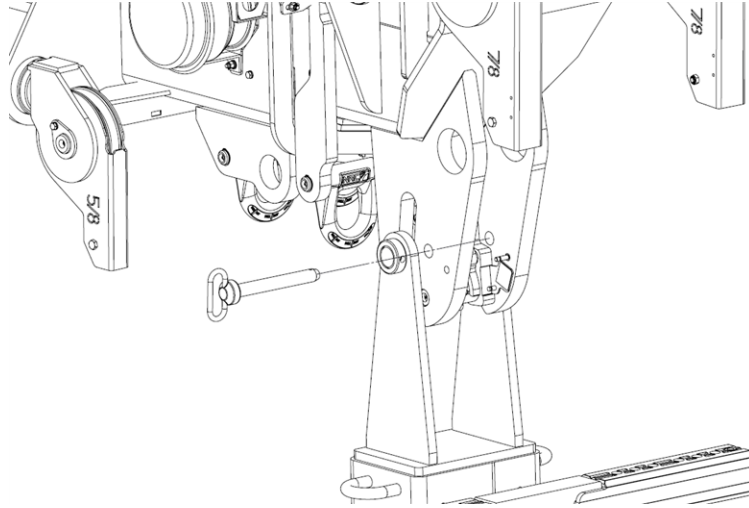

**FIGURE 23 – REMOVING THE SAFETY PIN**

- b. Slowly lower the boom until the automatic locking system unlocks (almost at the bottom of the underlift's slot).
- c. Raise the boom.

The underlift is now unhooked and the boom is ready for use.

### 3.8.4 Attaching the underlift to the boom

1. If the boom base is not entirely in front of the wrecker, slide it all the way forward so that it is in the slider lock.
2. If the boom has been rotated, rotate it back into its rotating lock position. If the boom has been extended, retract it until you can attach the underlift.
3. If your wrecker is equipped with the manual safety attachment, when the boom head hook is just below the storage pin in the top of the underlift, retract the boom until the safety attachment locks the boom to the underlift. If your wrecker is equipped with the automatic safety attachment, slowly lower the boom head hook onto the underlift until you hear the automatic safety attachment click. Install the safety pin.
4. Using the boom, slowly lift the underlift, just enough to allow the storage pin to slide out

of the hole.

5. Slide the storage pin out and store it in the toolbox.

The underlift is now hooked to the boom.

### 3.8.5 Removing the underlift from the wrecker

1. Unhook the underlift from the boom (see Section 3.8.3 Unhooking the underlift from the boom).
2. Disconnect the MultiFaster hydraulic coupler that connects the underlift to the body and place it in the docking bracket on the side of the underlift.



**FIGURE 24 – PUT THE HYDRAULIC LINES IN THE DOCKING BRACKET (EXAMPLE)**

3. Lift and align the boom so that there are a few feet of space between it and the top of the underlift.

4. Gently unwind the main winch cables and attach the cables to the eyes near the top of the underlift.

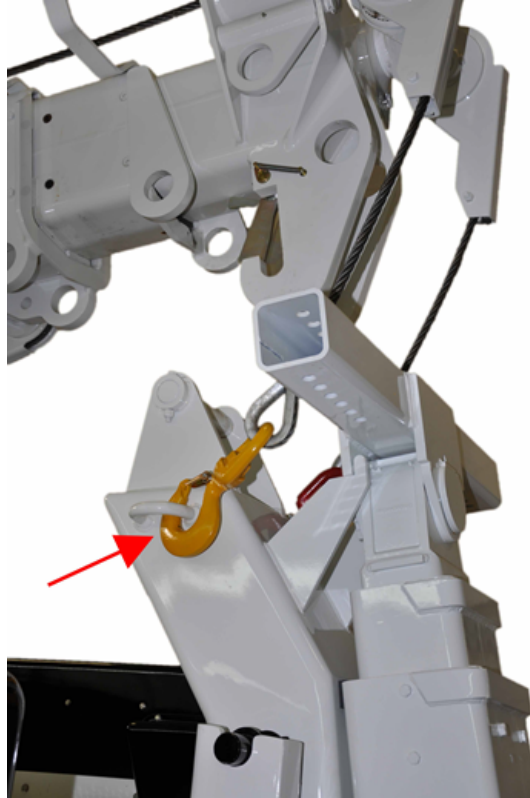

FIGURE 25 – ATTACHING THE CABLES TO THE EYES (EXAMPLE)

5. With the winches set to free spool, lift and extend the boom over the underlift. Position the boom so that there is enough clearance to fully lift the underlift and the wire ropes run straight up and down from the hook points.
6. Engage the winches and start lifting the underlift. Continue lifting until you start to see the underlift rollers.

## **⚠ WARNING**

**Stop lifting the underlift before the rollers leave their rails.**

7. Position the centre of gravity of the underlift by extending or retracting the boom until pressure is no longer exerted on the two roller guides in the underlift rails. Depending on your wrecker model, this pressure is generally relieved when the underlift forms a 25–30° vertical angle and the rollers are not touching the rails at the points indicated by arrows in the figure below.

## NOTICE

To prevent the underlift from swinging when it is lifted out of the rails, find its centre of gravity. If the underlift swings too much, it could hit the vehicle.

## ⚠ DANGER

Never allow anyone near the wrecker when removing the underlift. The underlift may swing and hit someone when it is removed, resulting in serious injury or death.

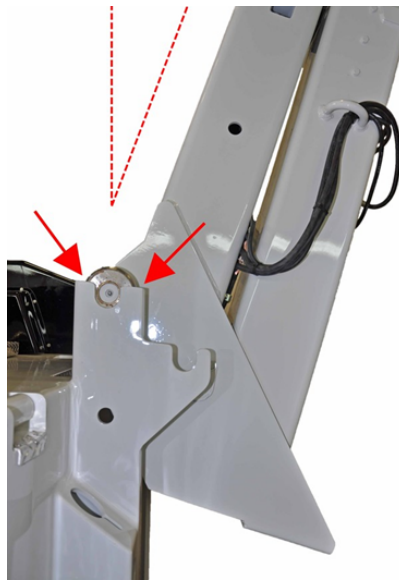

FIGURE 26 – POSITIONING THE UNDERLIFT IN THE RAILS (EXAMPLE)

8. Raise the boom until the underlift clears the rails.

9. Move the boom to put the underlift down on a firm surface. It is recommended that you lay the underlift flat behind the truck. When you first put the underlift down vertically, leave enough space behind the truck to lay the underlift flat. By unwinding the winch cables and possibly retracting the boom, you can bring the underlift down completely. This is shown in the figure below.

**⚠ DANGER**

**Never rest the underlift in a vertical position when it is not supported by the cables attached to the boom. An underlift is heavy and may fall. Always lay it flat on the ground.**

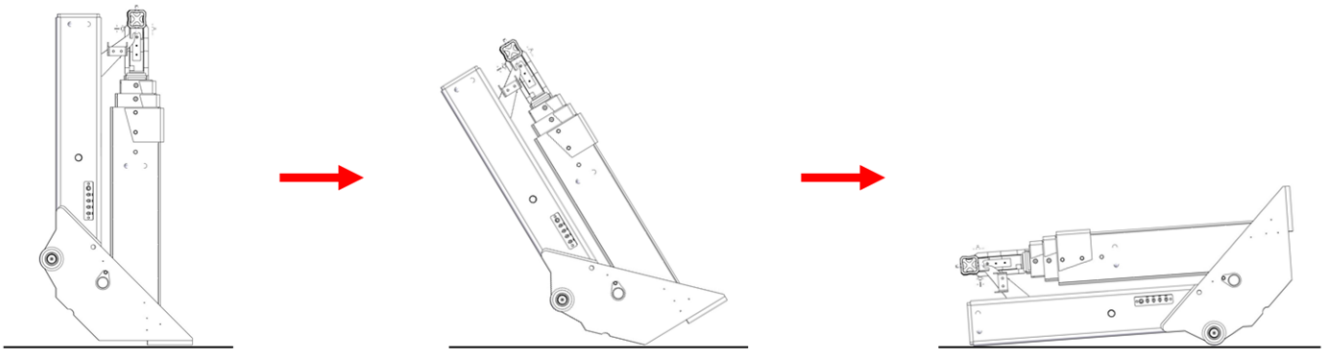

**FIGURE 27 – PLACING THE UNDERLIFT ON A FLAT SURFACE (EXAMPLE)**

10. Disconnect the two winch cables.

The boom is now ready for use.

### 3.8.6 Removing the tag axle from the wrecker

You can remove the tag axle from the wrecker in two ways:

- Remove the tag axle and the attached underlift at the same time. This is useful if you want to remove the tag axle and underlift from your wrecker and do not need the underlift.
- Remove the underlift from the tag axle, then remove the tag axle from the wrecker. This is useful if you need to reattach the underlift to the wrecker for jobs to be done with the underlift.

## Removing the tag axle and the attached underlift at the same time

To remove the tag axle and the attached underlift at the same time:

1. Stop the hydraulic pumps by turning off the truck engine or disengaging the PTO.
2. Ensure that the underlift is resting on its storage pin.
3. Secure the underlift to the tag axle with its two locking pins.

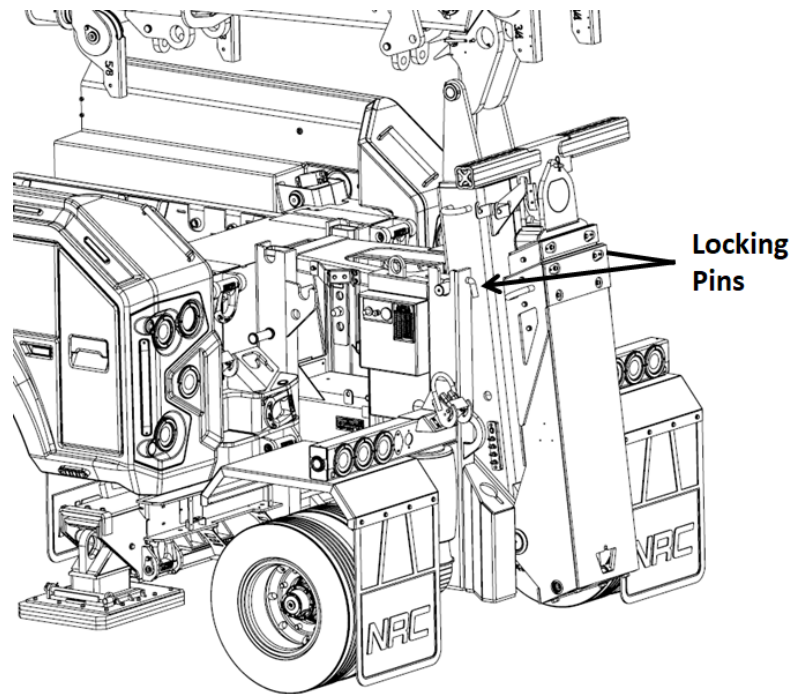

FIGURE 28 – SECURING THE UNDERLIFT TO THE TAG AXLE

4. Disconnect the MultiFaster hydraulic coupler that connects the underlift to the tag axle and place it in the docking bracket on the side of the underlift. Additionally, disconnect the electrical cable and three air hoses.



**FIGURE 29 – PLACING THE CABLES AND HOSES IN THE DOCKING BRACKET (EXAMPLE)**

5. Restart the engine or engage the PTO.
6. Slightly raise the boom to relieve the pressure on the pins securing the tag axle assembly to the wrecker tag axle rails. Remove the pins and store them.
7. Slightly extend or retract the boom so the tag axle's centre of gravity allows the tag axle to slide freely in the rails. Using the boom, lift the tag axle close to the end of the rails and ensure that it is still centred in the rails by slightly extending or retracting the boom.
8. Using the boom, slowly lift the tag axle out of the rails.

9. Once the tag axle is out of the rails, move the boom to put the tag axle down on a firm surface. Properly chock the tag axle's wheels to prevent the tag axle from moving. Place blocks under the tag axle and underlift so that the assembly stands securely upright and will not fall.

## **! DANGER**

**Never leave the tag axle on the ground without chocks in front of and behind the wheels to prevent it from moving. Also, make sure to securely stabilize the assembly with blocks. The tag axle is heavy and may fall if not properly secured with blocks, which could cause serious injury or even death.**

10. Unhook the underlift from the boom (see Section 3.8.3 Unhooking the underlift from the boom).

### **Removing the underlift from the tag axle, and then removing the tag axle from the wrecker**

To remove the underlift from the tag axle, and then remove the tag axle from the wrecker:

1. Remove the underlift from the tag axle (see Section 3.8.5 Removing the underlift from the wrecker), but instead of disconnecting the underlift's MultiFaster hydraulic coupler from the body, disconnect it from the tag axle.
2. Disconnect the MultiFaster hydraulic coupler that connects the tag axle to the body and place it in the docking bracket on the side of the tag axle.
3. Restart the engine or engage the PTO.
4. Lift and align the boom so that there are a few feet of space between it and the top of the tag axle.
5. Gently unwind the main winch cables and attach the cables to the eyes near the top of the tag axle.
6. Slightly raise the boom to relieve the pressure on the pins securing the tag axle to the wrecker tag axle rails. Remove the pins and store them.
7. Slightly extend or retract the boom so the tag axle's centre of gravity allows the tag axle to slide freely in the rails. Using the boom, lift the tag axle close to the end of the rails and ensure that it is still centred in the rails by slightly extending or retracting the boom.
8. Using the boom, slowly lift the tag axle out of the rails.

9. Once the tag axle is out of the rails, move the boom to put the tag axle down on a firm surface. Properly chock the wheels of the tag axle to keep the tag axle from moving. Place blocks under the tag axle so that the tag axle stands securely upright and will not fall.

## **! DANGER**

**Never leave the tag axle on the ground without chocks in front of and behind the wheels to prevent it from moving. Also, make sure to securely stabilize the tag axle with blocks. The tag axle is heavy and may fall if not properly secured with blocks, which could cause serious injury or even death.**

10. Disconnect the two winch cables.

### **3.8.7 Attaching the underlift to the wrecker**

When the underlift has been removed, you must put it back on the wrecker before leaving the site.

1. Position the boom and the winch cable hooks so that you can attach the winch cable to the underlift.
2. Connect the two winch cables to the eyes near the top of the horizontal part of the underlift stinger.
3. Wind in the winch cables and, if needed, extend the boom to lift the underlift.
4. Raise the boom so the underlift is high enough to clear the underlift rails.
5. Lower the boom and align the underlift rollers with the rails. Continue lowering and possibly retracting the boom so the underlift goes into its rails.
6. Insert the storage pin in the pin hole in the underlift. Continue moving the underlift into its rails and stop when the underlift is supported on the storage pin.
7. Reconnect the MultiFaster hydraulic coupler that connects the underlift to the wrecker (on the multi-coupler).
8. Hook the underlift to the boom (see Section 3.8.4 Attaching the underlift to the boom).

## 3.9 Using the boom

The boom is normally used to lift a load or another vehicle for towing. The boom can be rotated and slid toward the front or rear of the vehicle, allowing you to lift a load from anywhere around the wrecker. The position and weight of the load will determine which procedures in this section you will need to use.

Before operating the boom, unhook it from the underlift. You can also completely remove the underlift to move the wrecker closer to the load.

### **! DANGER**

**Before operating the boom, make sure you understand the principles of operation (see Section 3.1 Operating principles) and follow the safety guidelines (see Section 3.3 Safety guidelines). Perform all the preliminary steps to ensure that the wrecker is stable and level (see Sections 3.4 Familiarizing yourself with the equipment, 3.7.1 Stabilizing the wrecker using the outriggers and 3.7.2 Levelling the wrecker).**

### 3.9.1 Preparing the slider and rotator

To allow the boom to move, you first need to unlock the slider and rotator using the touchscreen interface.

To unlock the slider, you may have to move the slider forward to relieve any pressure on the locks.

To unlock the rotator, you may have to move the rotation control lever back and forth to relieve any pressure on the locks.

To move the boom forward or backward:

1. Ensure that both rails are well lubricated. If your wrecker is equipped with the automatic grease pump and is set to automatic mode on the touchscreen interface, ensure that the grease tank has enough grease and that the system is working properly.

**NOTE:** Use Teflon grease to lubricate the rails (see Section 4.2.1 General wrecker maintenance).

2. Slide the boom base back and forth a few times over the entire stroke of the slider to spread the grease evenly.

### 3.9.2 Rotating the boom

1. Ensure that the boom rotation is unlocked on the touchscreen interface.
2. Push the boom rotation lever up or down to rotate the boom in either direction.

**NOTE:** You can increase the boom rotation speed by activating the high-speed function on the touchscreen interface. This function also controls the winding and unwinding speed for the two main winch cables. Adjust the speed control function to operate at low speed when working under load.

The boom can rotate continuously over the cab. When the boom approaches the cab, an electronic safety stop will activate and prevent the boom from continuing to rotate. To rotate the boom over the cab, you will need to acknowledge the warning message on the touchscreen interface (see the manual for your touchscreen model).

## NOTICE

**Once you acknowledge the warning message, you can rotate the boom over the cab without any limitations, as long as the boom stay within the cab's safety zone. The safety system will reactivate when the boom exits the cab's safety zone. Ensure that the boom and load always remain at a safe distance from the cab.**

### 3.9.3 Sliding the boom

1. Ensure that the slider is unlocked on the touchscreen interface.
2. Push the boom slider lever up or down to slide the boom forward or backward.

### 3.9.4 Locking the boom in storage position

Once you have completed a job, lock the boom in its storage position.

1. On the left-hand side control panel, use the boom rotation lever to centre the boom.
2. Use the boom slider lever to slide the boom all the way forward.
3. On the touchscreen interface, check that the boom is centred.
4. Use the touchscreen interface to lock the boom rotation and check that it is locked. Push the rotation lever up and down to ensure that the locks are activated (the boom does not rotate) and the boom is securely in its storage position.
5. Use the touchscreen interface to lock the slide and check that it is locked. Push the slider lever up and down to ensure that the locks are activated (the boom does not slide forward or backward) and the boom is safely stored.

## 3.10 Using the winches

The wrecker has up to five winches, which can be used for winching or for lifting a load or another vehicle.

You can operate the winches using the controls on either control panel or on the remote control. Use the controls that will provide the best visibility and enable you to work safely.

To operate the wrecker, you will need to engage one or more winches, depending on the load size and weight. You may also need to disengage the winches for operations such as extending the boom.

### **! DANGER**

**Before extending the boom, make sure the winch cables or synthetic ropes can move freely or are disengaged. Do not extend the boom if the hook is attached to the wrecker body. This could damage the cables, winches and sheave heads, and cause injury or even death.**

**IMPORTANT:** This section provides general information on how to use the winches. NRC equipment uses winches of various brands and models. Always refer to the winch manufacturer manual for information specific to your winch.

### 3.10.1 Recommended break-in procedure

The winch cables installed on your new wrecker are ready to use and do not require any break-in procedures. When installing a new cable on the winch, make sure to follow any break-in procedures as instructed by the cable manufacturer.

### 3.10.2 Disengaging and engaging the winches

Each winch has its own lever on the control panels and on the remote control.

Use the touchscreen interface or remote control button to disengage or engage a winch. Push the corresponding winch lever up and down several times to release the pressure on the clutch and fully disengage the winch.

**NOTE:** After engaging the winch, wait at least five seconds before using it to ensure that the air clutch is properly engaged.

## DANGER

**Never disengage a winch that is under load.**

### 3.10.3 Winding and unwinding the winch cable

Once a winch is properly engaged, push its control lever up or down to wind or unwind the cable.

You can increase the winding and unwinding speed of the main winch cable by activating the high-speed function on the touchscreen interface. This function also controls the boom rotation speed. Adjust the speed control function to operate at low speed when working under load.

## CAUTION

**For safer operation, it is recommended to never leave the equipment on the high speed option. Always put it back on low speed after each operation.**

### 3.10.4 Locking the winches in storage position

1. Engage each winch.
2. Wind the winch cable in fully.

## NOTICE

**Do not over-wind the cable and cause the hook to exert tension on the pulley. This could result in severe damage.**

## 3.11 Using the remote control

Your wrecker may be equipped with a remote control that has control levers. The remote control is used to control the wrecker from afar, where you can remain at a safe distance from the load and more easily see what you are doing while operating the controls.

### 3.11.1 Preparing to use the remote control

To prepare for using the remote control:

1. Put the remote control somewhere comfortable, such as on a belt around your waist or neck. Wearing it on your waist will allow you to move the remote control to your back, which will protect it while you perform various tasks.
2. Turn the remote control on. If it is turned off when the option to control the wrecker with the remote control is selected, the truck will turn off.
3. On the touchscreen interface, select the option to control the wrecker with the remote control.

### 3.11.2 Operating the wrecker with the remote control

To operate the wrecker using the remote control:

- To turn the wrecker engine on or off, use the appropriate switch on the remote control (see Table 2).
- To disengage a winch, push and hold the corresponding winch button. Release the button to engage the winch.
- To rotate the boom and wind and unwind the winch cable at high speed, toggle the speed switch to the high position. Toggle the speed switch to the low position to return to slow speed.
- You can perform all other functions using the remote control levers as you would with the control panel.
- In the event of an emergency, use the emergency stop button to turn off the truck and the remote control.

After you are done controlling the wrecker using the remote control, use the touchscreen to deactivate remote control operation.

## 3.12 Using the touchscreen interface

The touchscreen interface has been designed to help you troubleshoot, adjust and diagnose the wrecker. It can be used to perform many actions, such as viewing the hours of operation, calibrating the system, viewing the system information, modules and logs, and setting your preferences.

Your wrecker is equipped with the MD4-7 model. See the manual for your touchscreen model.



## 4 MAINTENANCE

Regular maintenance can prevent problems and damage to equipment. This chapter contains safety guidelines, maintenance procedures and the recommended maintenance schedule for your wrecker.

**NOTE:** See the winch manufacturer manual for more details about winch maintenance.

### 4.1 Safety guidelines

When performing maintenance on your wrecker, underlift, boom or winches, always:

- Ensure that you fully understand all the safety rules described in Chapter 2 Safety.
- Wear protective clothing (goggles, gloves, footwear, etc.)
- Watch out for moving parts.
- Watch out for hot components.
- When working under the vehicle, apply the parking brake and use wheel chocks.
- When lifting the vehicle, use approved and certified equipment that is in good condition.

For winch safety guidelines, see the winch manufacturer manual.

## 4.2 General maintenance

NOTE: Remember that regular maintenance will keep your wrecker in good condition, extend its lifespan and reduce the risk of damage and breakage.

### 4.2.1 General wrecker maintenance

Description	After		Every					
	1st use	1 mth	1 day	2 wks	1 mth	3 mths	6 mths	1 yr
Adjust the hydraulic pressure. See Section 4.4.1 Adjusting the hydraulic pressure (main relief).						X		
Check the cable tensioner for all winches. See Section 4.2.4 Winch cable tensioner. Check the dial on the right side of the wrecker. The dial should indicate a pressure of approximately 75 to 90 psi (5.2 to 6.2 bar) to maintain the correct cable pressure.						X		
Inspect the bolts on the chassis mounting plates for damage and make sure they are tight. Have an NRC-authorized distributor inspect the chassis mounting plates for cracks or structural damage. See Section 4.2.2 Mounting plates maintenance.	X				X			
Visually inspect the bolts for the rotator bearing. See Section 4.4.								X

Description	After		Every					
	1st use	1 mth	1 day	2 wks	1 mth	3 mths	6 mths	1 yr
Replace all the oil filters (pressure and return filters). Clean the inlet filters and test the hydraulic fluid.		X						X
Inspect the equipment to ensure that it is in good condition for the next job.			X					
Lubricate the two bolts that hold the emergency hydraulic bypass cover in place.							X	
Lubricate the two pins on the MultiFaster.					X			
Visually inspect the cable(s) to ensure that they are in good condition, lubricated and properly wound. See Section 4.2.5 Steel cable maintenance.			X					
Check that no cylinders or hoses are leaking.			X					
Inspect all anchors, eyes and pulleys for cracks and structural damage.			X					
Check the condition of the high-pressure oil filter and that all the high-pressure indicators are green. If the indicators are red, replace the filter. The indicators are located directly on the filter.				X				

Description	After		Every					
	1st use	1 mth	1 day	2 wks	1 mth	3 mths	6 mths	1 yr
Visually inspect the wear pads to ensure that they are in good condition. If they are in poor condition, replace them. See Section 4.2.6 Wear pads maintenance.				X				
Clean and lubricate the lever arms on the main control valve. Remove the cover from the manual override control panel to access the main control valve.						X		
Clean the levers on the manual override control panel.						X		
Have an NRC-authorized distributor check the hydraulic system. See Section Authorized distributors and service providers.								X

## 4.2.2 Mounting plates maintenance

NRC recommends that wrecker mounting plates be inspected **every month** by trained and qualified personnel, and annually by an authorized NRC distributor. Should a visual inspection identify any cracks or structural damage, immediately discontinue use until the equipment is deemed safe.

**After the first use and every month**, inspect the bolts on the chassis mounting plates for damage and make sure they are tight.

## 4.2.3 Winch maintenance

See the winch manufacturer manual.

## 4.2.4 Winch cable tensioner

Check all the indicators for the cable tensioner for all winches. There is one pressure gauge between the main winches, and one pressure gauge between the auxiliary winches (for models with auxiliary winches). To maintain adequate tension on the cable, it should read approximately 80 psi. Adjust the pneumatic pressure using the integrated regulator when necessary.

## 4.2.5 Steel cable maintenance

Steel cables must be regularly inspected to ensure safe operation. When a cable is degraded, deformed or bent, you must replace it. See the ISO 4309:2017 standard for the criteria for inspection, maintenance and disposal of steel cables.

The cable dimensions vary based on the winch model. Figure 30 below shows the locations of winches equipped with steel cables on each wrecker model. For equipment sold in North America, the table below shows the cables used for each winch model.

**IMPORTANT:** NRC only supplies steel cables for equipment sold in North America (NRC does not supply steel cables where Standard 14492 is applicable). When NRC does not supply the winch cable, the client or distributor must select the appropriate cable for their winch model in accordance with applicable standards and regulations.

**TABLE 15 – STEEL CABLES FOR THE DIFFERENT WINCH MODELS (NORTH AMERICA ONLY)**

Description	Wrecker Model	Winch Location	Length (ft.)	Cable Specification
Steel cable for Ramsey HD-P 40000 winch	CSR50	Main	200	19 mm (3/4”) 6x36 (WS) EIPS 1960 IWRC
Steel cable for the Ramsey RPH 15 000 winch	CSR50	Auxiliary	200	14 mm (9/16”) 6x36 (WS) EIPS 1960 IWRC
Steel cable for DP 50000 winch	CSR65	Main	200	22 mm (7/8”) 6x36 (WS) EIPS 1960 IWRC
Steel cable for DP 20000 winch	CSR50 and CSR65	Auxiliary	200	16 mm (5/8”) 6x36 (WS) EIPS 1960 IWRC
Steel cable for DP 60000 winch	CSR85	Main	200	22 mm (7/8”) 6x36 (WS) EIPS 1960 IWRC
Steel cable for DP 25000 winch	CSR85	Auxiliary	200	16 mm (5/8”) 6x36 (WS) EIPS 1960 IWRC
Steel cable for DP 50000 winch	CSR50, CSR65 and CSR85	Drag	360	19 mm (3/4”) 6x36 (WS) EIPS 1960 IWRC

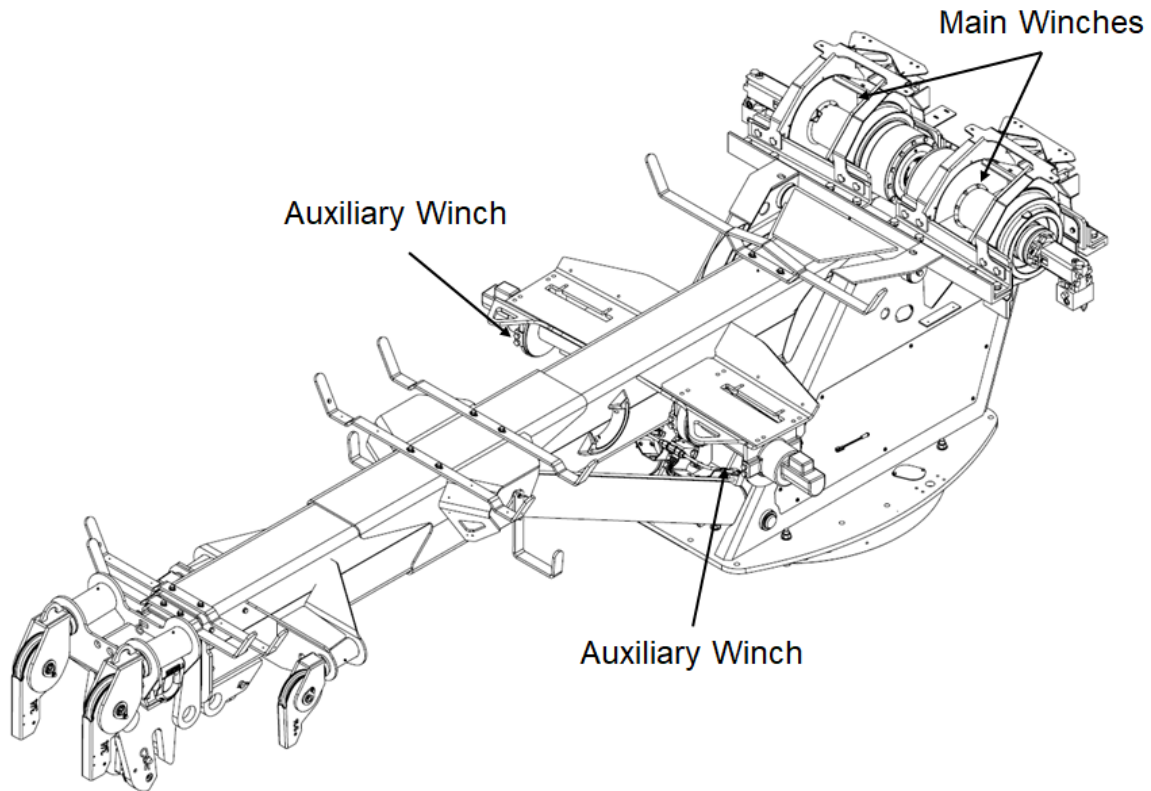

FIGURE 30 – WINCH LOCATIONS

#### 4.2.6 Wear pads maintenance

Wear pads must be replaced according to the replacement frequency and other information shown in Table 16. Make sure to recycle or dispose of the worn wear pads in accordance with local legislation.

TABLE 16 – WEAR PADS

Description	Quantity	Replacement Frequency	Location
Underlift wear pads	3-section underlift: 4 3-section underlift Euro: 8 4-section underlift: 12	Before the thickness of the nylatron reaches the fixing bolt	On the tube of the different sections. See Figure 31.
Boom wear pads	6	When the thickness of the nylatron reaches the fixing bolt or anchor	On the tube of the different sections. See Figure 32.
Outrigger wear pads	Front outriggers: 16 Rear outriggers: 16	When the thickness of the nylatron reaches the fixing bolt or anchor	On the tube of the different sections. See Figure 33 and Section 4.4.7 Disassembling the outriggers.
Slider wear pads	12	When the thickness of the nylatron reaches the anchor of the wear pads	On the lower part of the slider. See Figure 34.

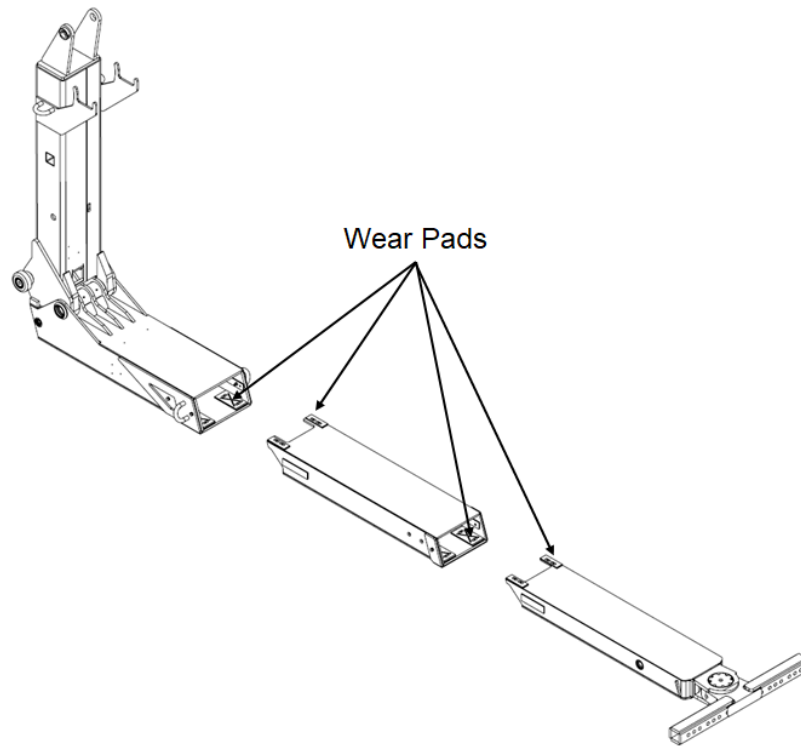

FIGURE 31 – WEAR PADS - UNDERLIFT

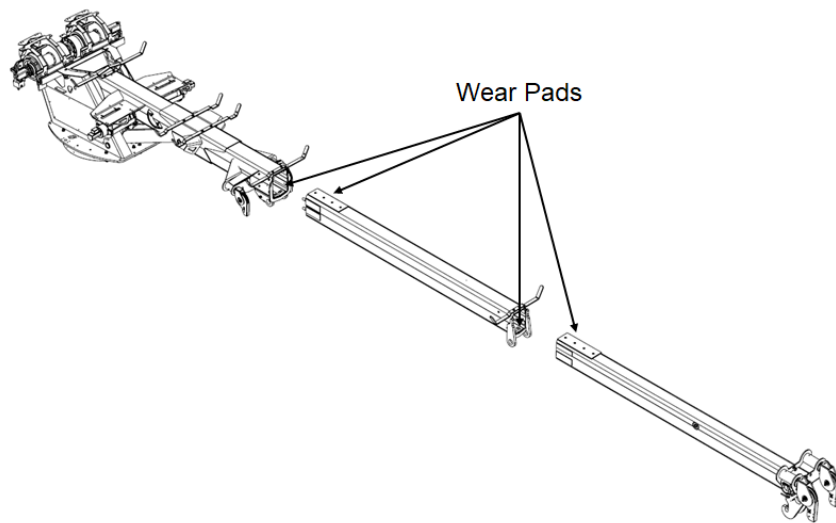

FIGURE 32 – WEAR PADS - BOOM

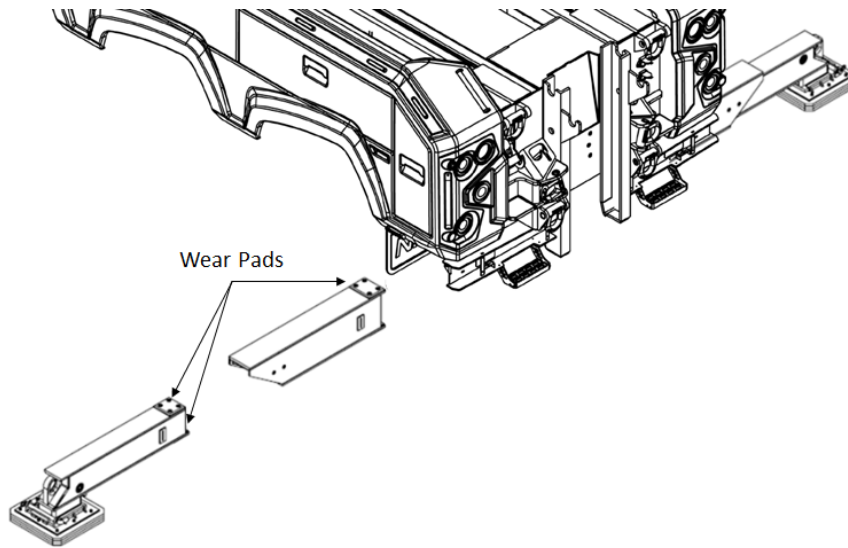

FIGURE 33 – WEAR PADS - OUTRIGGERS

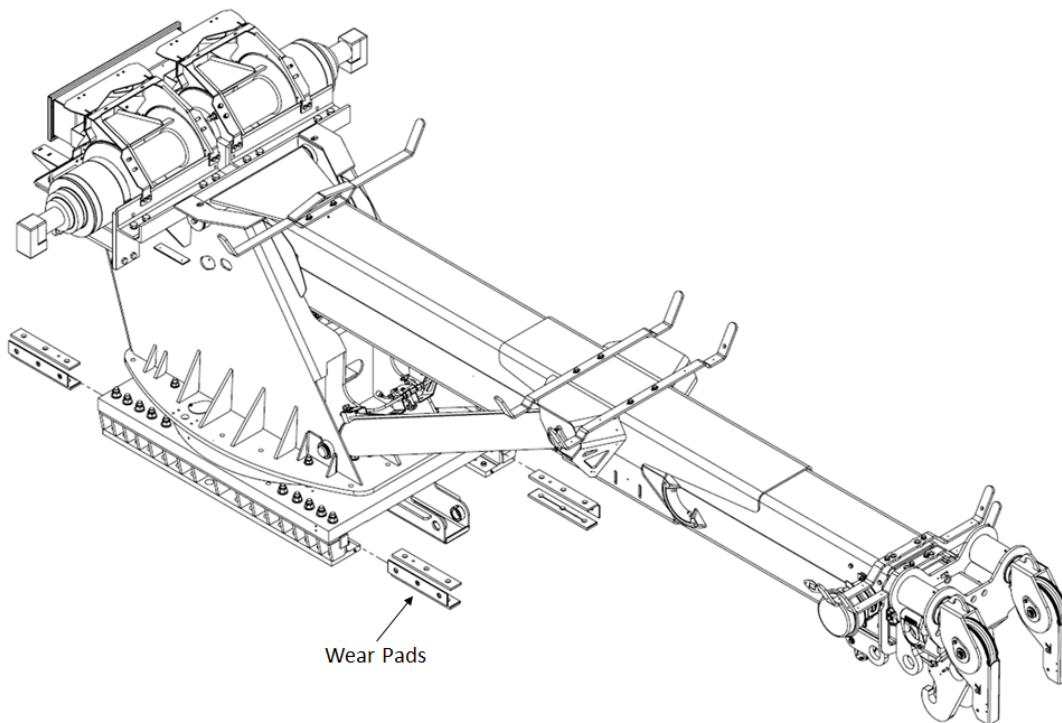

FIGURE 34 – WEAR PADS - SLIDERS

## 4.3 Lubrication

This section details the lubrication points and schedule for the various parts of your wrecker. Make sure to use the oil recommended by the manufacturer of each component.

### 4.3.1 Oil

**IMPORTANT:** NRC wreckers use oil for the hydraulic system, winches and swing drive. When changing the oil, take care not to spill any. Collect the oil in a leak-proof can or container and bring it to your nearest collection point for recycling.

**NOTE:** Oil types for other equipment included with NRC equipment (e.g. winch) are provided for reference only. See the manufacturer's manual (e.g. winch manufacturer's manual) for the appropriate oil type and frequency for your application and model.

**TABLE 17 – OIL TYPES AND LOCATIONS**

Description	Quantity	Oil Type or Commercial Name	Frequency	Location
Hydraulic oil	Fill up to 3 in. from the top of the tank	Hydrex MV 32 (T-22 or T-32 or AW-32)	Every week. Add oil if needed.	Oil tank located at the front of the equipment. See Figure 35.

Description	Quantity	Oil Type or Commercial Name	Frequency	Location
Oil for the Ramsey HD-P 40000 winch	Fill to the level indicated on the winch	SAE 75W-90. See the winch manufacturer's manual	Every week. Add oil if needed. Replace oil at least every year or more frequently depending on usage.	Winch oil tank. See Section 4.2.5 Steel cable maintenance for the location of the winch.
Oil for the Ramsey RPH 15000 winch*	N/A	N/A	N/A	N/A
Oil for the DP 20000, DP 25000, DP 50000 and DP 60000 winches	Fill to the level indicated on the winch	80W90 or 85W140 depending on the operating temperature. See the winch manufacturer's manual	After the first 10 hours of operation. Then annually or at every 250 hours of operation.	Winch oil tank. See Section 4.2.5 Steel cable maintenance for the location of the winch.
Oil for the winch cables	Along the full length of the cables, as required by the cable manufacturer	Lubricant for steel cables	4 to 6 months	All winch cables
Oil for the swing drive	Fill to the level indicated on the swing drive	OMALA 220	After the first 150 hours of operation. Then at least every 2 years or more frequently depending on usage	Swing drive. Raise the boom to access the swing drive. See Figure 36.

\*The RPH 15000 winch does not need additional oil.

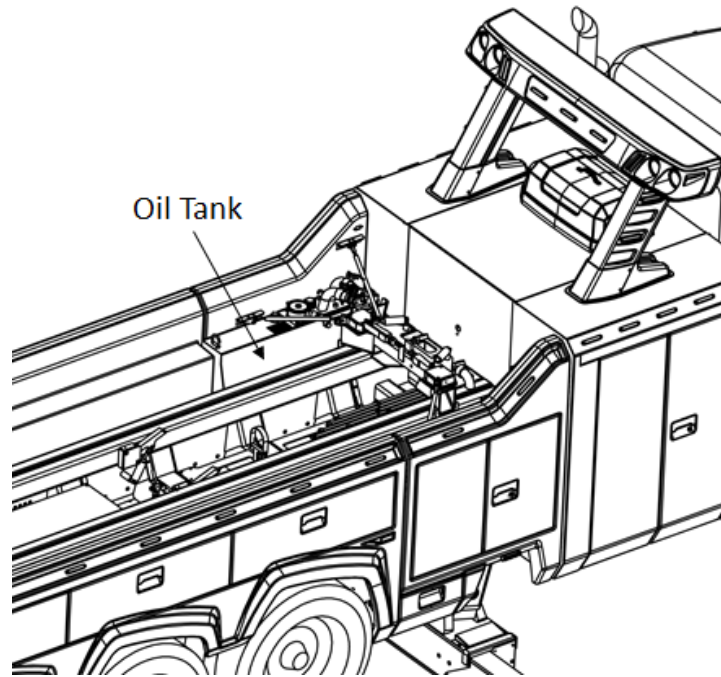

FIGURE 35 – OIL TANK - CSR50 AND CSR65

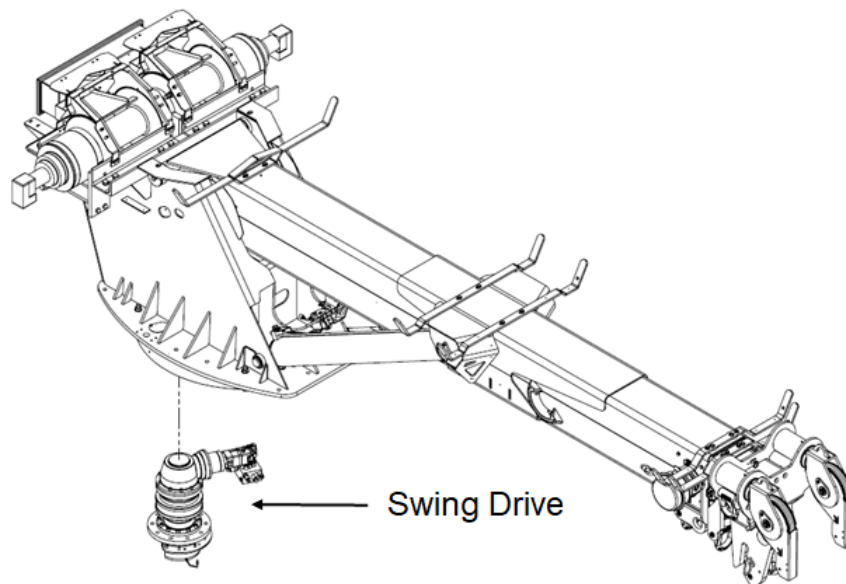

FIGURE 36 – SWING DRIVE LOCATION

### 4.3.2 Oil filter cartridges

NRC wreckers include high-pressure filters and return filters. The cartridges for these filters must be replaced according to the schedule shown in the tables below. The cartridge model and locations depend on the wrecker model. Contact your NRC distributor for the cartridge model number that applies to your wrecker model.

**TABLE 18 – FILTERS FOR THE CSR50**

Description	Quantity	Commercial Name	Replacement Frequency	Location
High-pressure filter	2	Hydac high-pressure filter with visual indicator	Every year	To access the high-pressure filter, move the boom back. See Figure 37.
Return filter	1	MP Filtri MPF return filter	After the first 6 months. Then every year.	On the oil tank. See Figure 37.

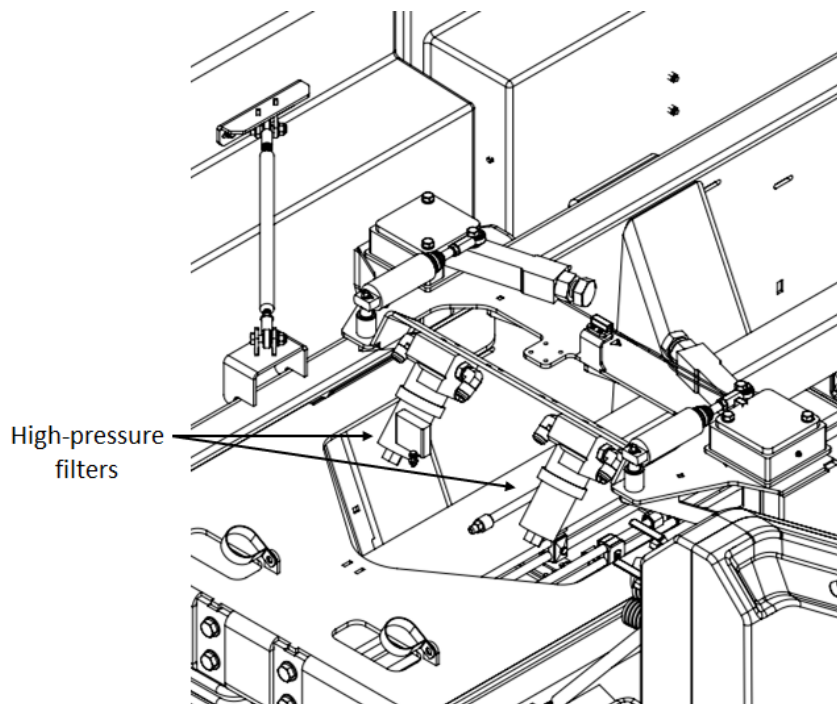

**FIGURE 37 – HIGH-PRESSURE FILTERS – CSR50**

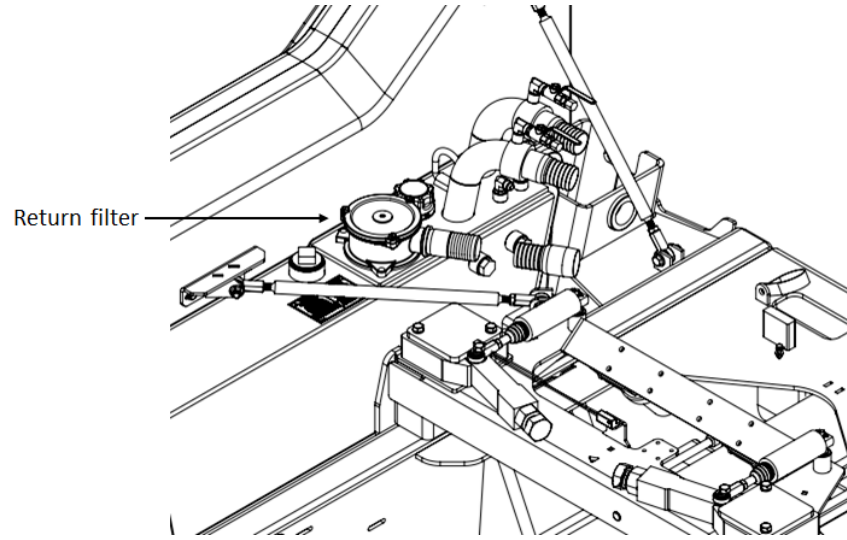

**FIGURE 38 – RETURN FILTER – CSR50**

TABLE 19 – FILTERS FOR THE CSR65

Description	Quantity	Commercial Name	Replacement Frequency	Location
High-pressure filter	2	Hydac high-pressure filter with visual indicator	Every year	The high-pressure filters are located inside the tunnel toolbox. Open the small doors in the toolbox to access the filters. See Figure 39.
Return filter	1	MP Filtri MPF return filter	After the first 6 months. Then every year.	On the oil tank. See Figure 39.

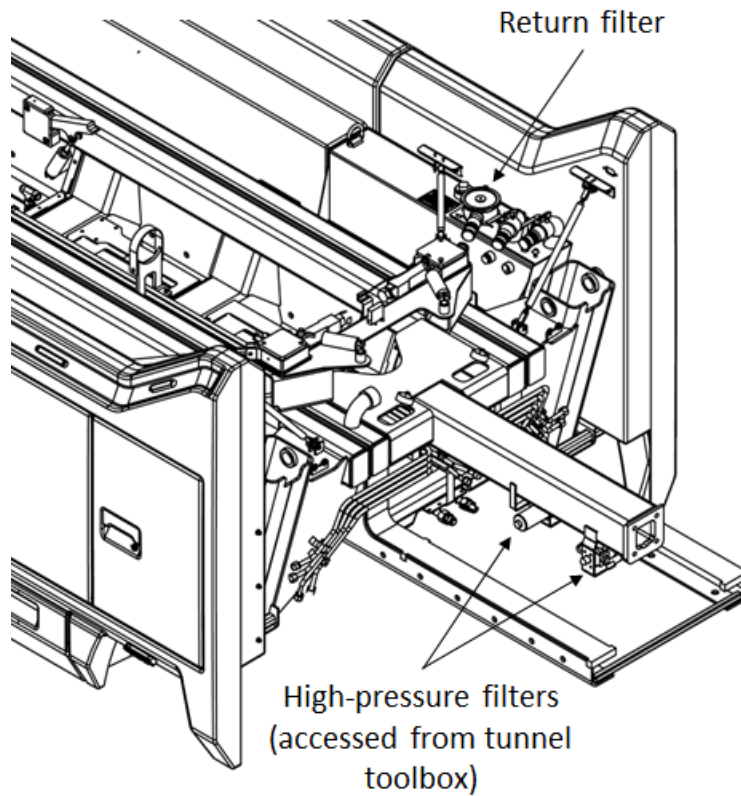

FIGURE 39 – FILTERS - CSR65

TABLE 20 – FILTERS FOR THE CSR85

Description	Quantity	Commercial Name	Replacement Frequency	Location
High-pressure filter	1	Hydac high-pressure filter with visual indicator	Every year	To access the high-pressure filter, move the boom back. See Figure 40.
Return filter	1	MP Filtri MPF return filter	After the first 6 months. Then every year.	On the oil tank. See Figure 40.

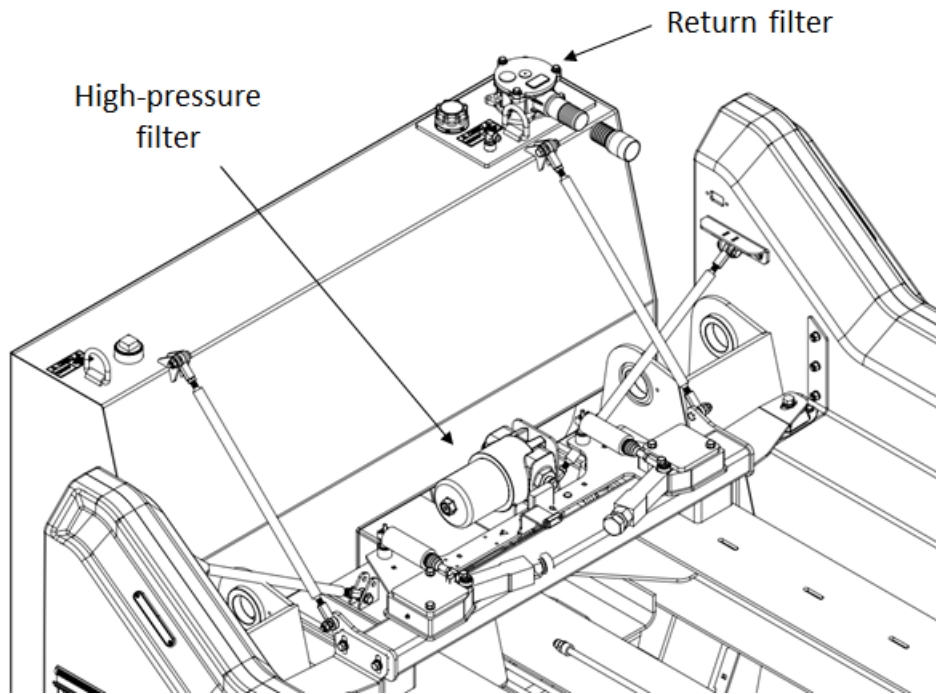

FIGURE 40 – FILTERS - CSR85

### 4.3.3 Grease

See Table 21 for the lubricant type and frequency of each component. See Table 22 to Table 30 for the lubrication point locations of each component.

**NOTE:** The number of grease fittings may vary depending on the models of the components you have on your wrecker. The figures below show the left side, right side, or front or rear component. The same lubrication points are also present on the other side (left, right) and front and rear if the same components are present. For example, if your wrecker has 4 outriggers, make sure to grease all grease fittings, even if the outrigger shown below is for the left outrigger.

**TABLE 21 – GREASE SCHEDULE**

Description	Lubricant Type	After	Every		
		6 mths	1 mth	3 mths	1 yr
Underlift surfaces and grease fittings	Waterproof grease		X		
Outrigger surface	Waterproof grease		X		
Boom and winches	Waterproof grease	X			X
Mast surfaces	Waterproof grease			X	
All valves (must be coated in grease)	Antifreeze white grease				X
Sliding base	Waterproof grease			X	

**TABLE 22 – LUBRICATION POINTS - UNDERLIFT**

**NOTE:** The number of grease fittings may vary depending on your underlift model.

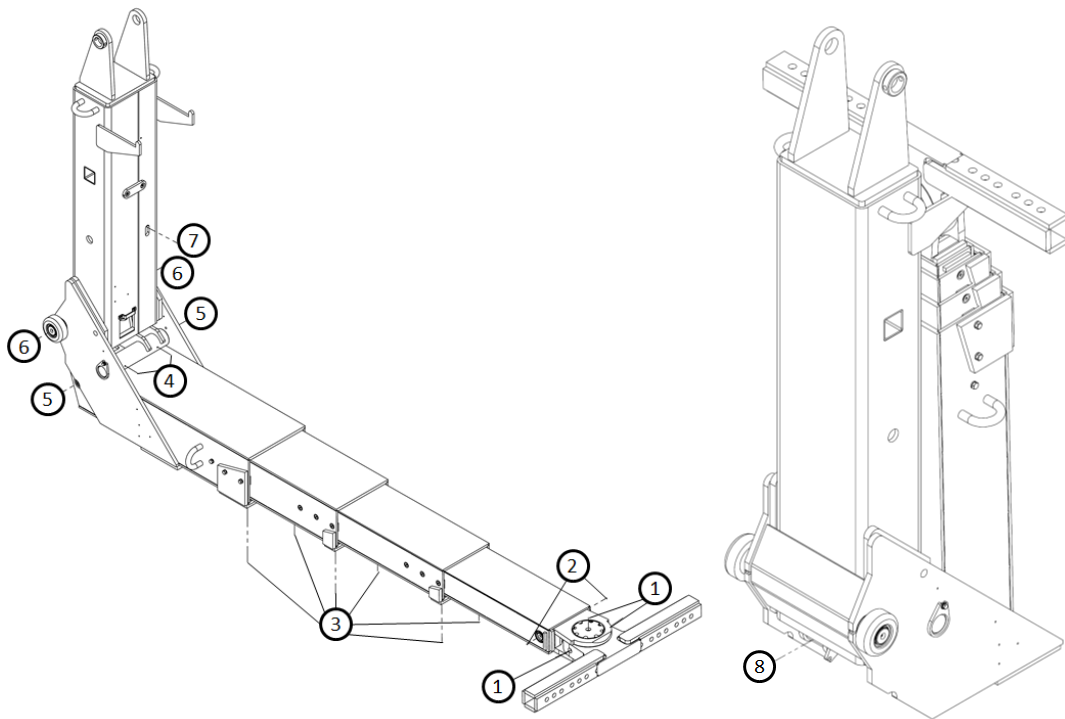

#	Lubrication point	Type
1	T-bar pivot	Grease fitting
2	Extension cylinder anchor point	Grease fitting
3	Sliding surfaces of each extension (Note 1)	Surface
4	Fold pivot	Grease fitting
5	Extension cylinder anchor point	Grease fitting
6	Underlift roller	Grease fitting
7	Fold cylinder anchor point	Grease fitting
8	Fold cylinder anchor point (Note 2)	Grease fitting

Note 1: Fully extend the underlift to access all sliding surfaces.

Note 2: Completely fold the underlift to access the grease fitting.

TABLE 23 – LUBRICATION POINTS - OUTRIGGERS

NOTE: The number of grease fittings may vary depending on your outrigger model. The figure below shows the left side of the outrigger. The same lubrication points are also present on the right side, on the front and rear outriggers.

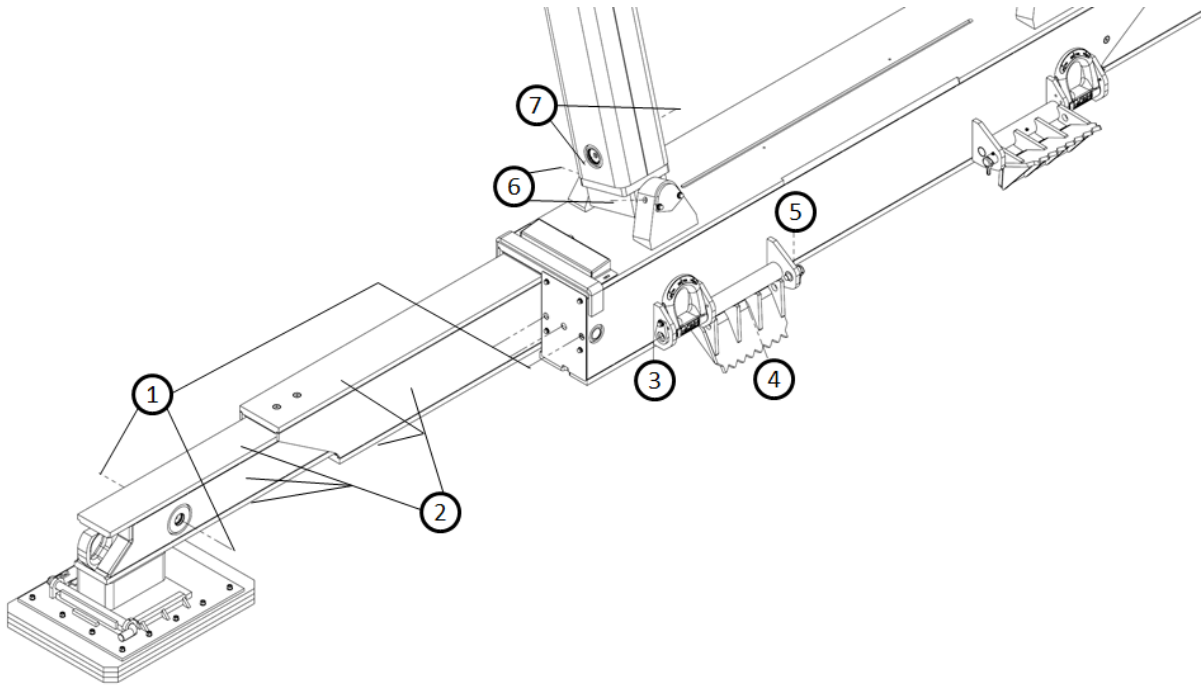

#	Lubrication point	Type
1	Extension cylinder anchor point	Grease fitting
2	Sliding surfaces of each extension (Note 1)	Surface
3	D-ring	Grease fitting
4	Recovery spade	Grease fitting
5	Recovery spade plunger lock	Grease fitting
6	Outrigger leg anchor point	Grease fitting
7	Outrigger elevation cylinder anchor point	Grease fitting

Note 1: Fully extend the outriggers. Lubricate the surface (top, sides, bottom) of every extension. Move the outriggers in and out several times to spread the grease evenly on all surfaces. Regularly and thoroughly grease the outriggers so their surfaces are always lubricated and protected against corrosion.

TABLE 24 – LUBRICATION POINTS - OUTRIGGERS - TOP ANCHOR POINTS

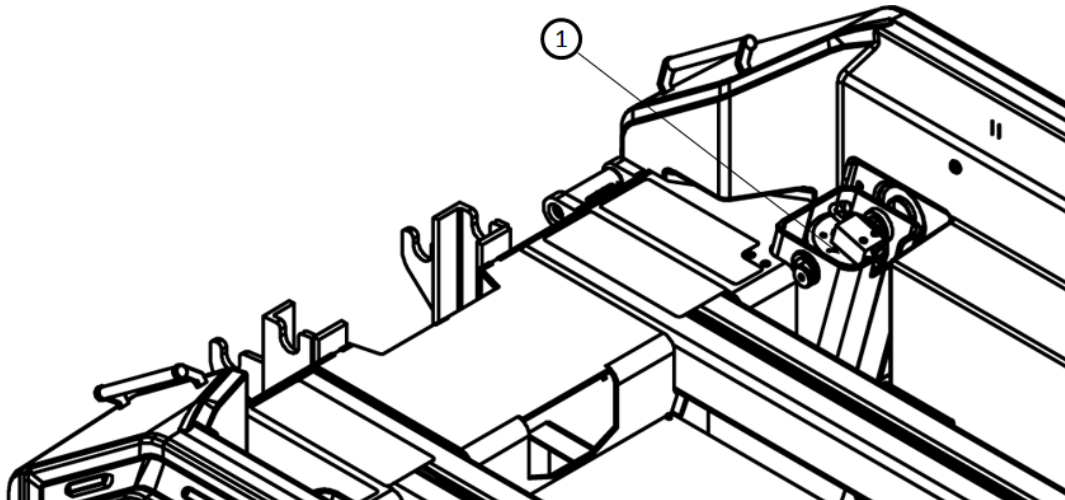

#	Lubrication point	Type
1	Outrigger elevation cylinder anchor	Grease fitting

TABLE 25 – LUBRICATION POINTS - REAR D-RINGS

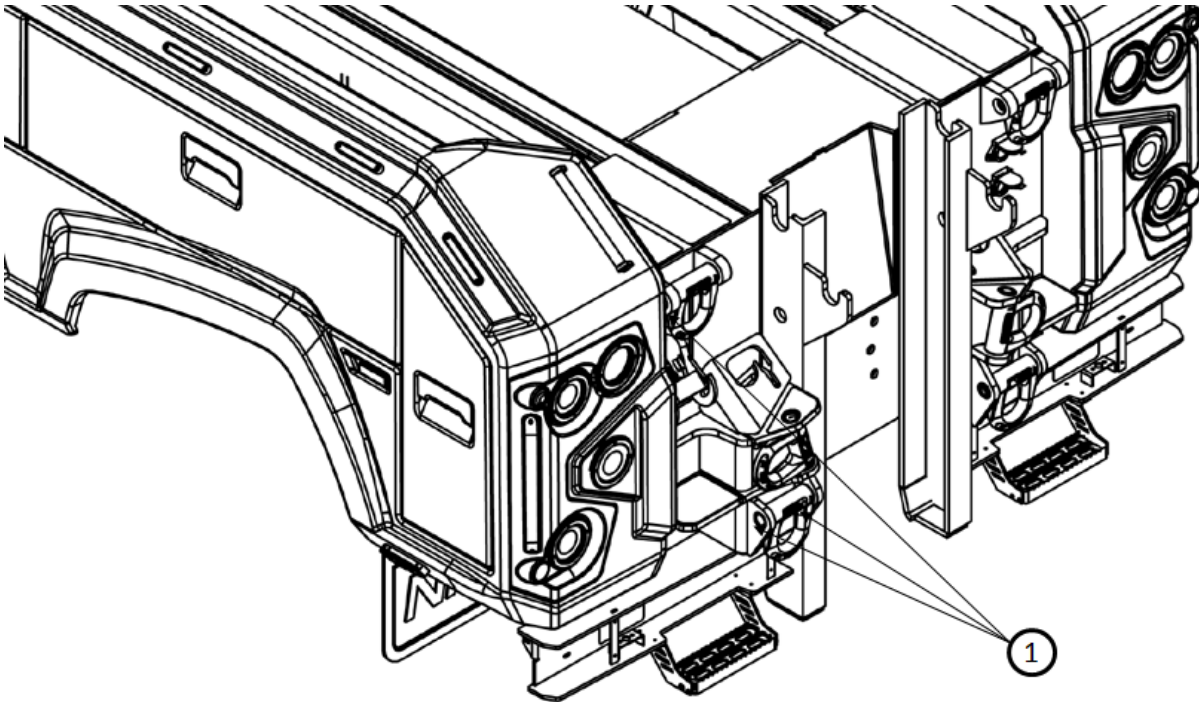

#	Lubrication point	Type
1	D-Ring	Grease fitting

TABLE 26 – LUBRICATION POINTS - WINCHES

NOTE: See the manufacturer's manual for the appropriate grease type and frequency for your application and model.

TABLE 27 – LUBRICATION POINTS - BOOM EXTENSION CYLINDERS

NOTE: The number of grease fittings may vary depending on your boom model.

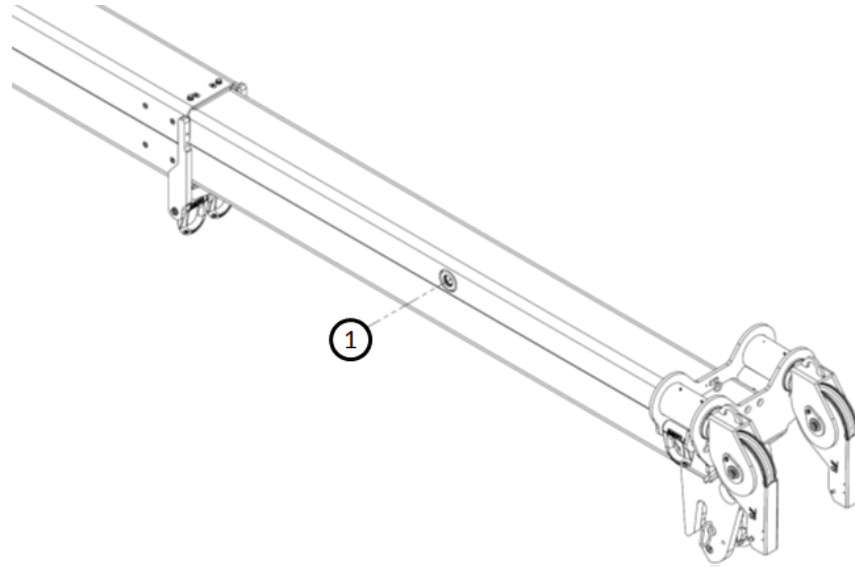

#	Lubrication point	Type
1	Boom extension cylinder anchor point (2 per extension) (Note 1)	Grease fitting

Note 1: Extend the boom to access the fittings.

**TABLE 28 – LUBRICATION POINTS - BOOM**

**NOTE:** The number of grease fittings may vary depending on your boom model.

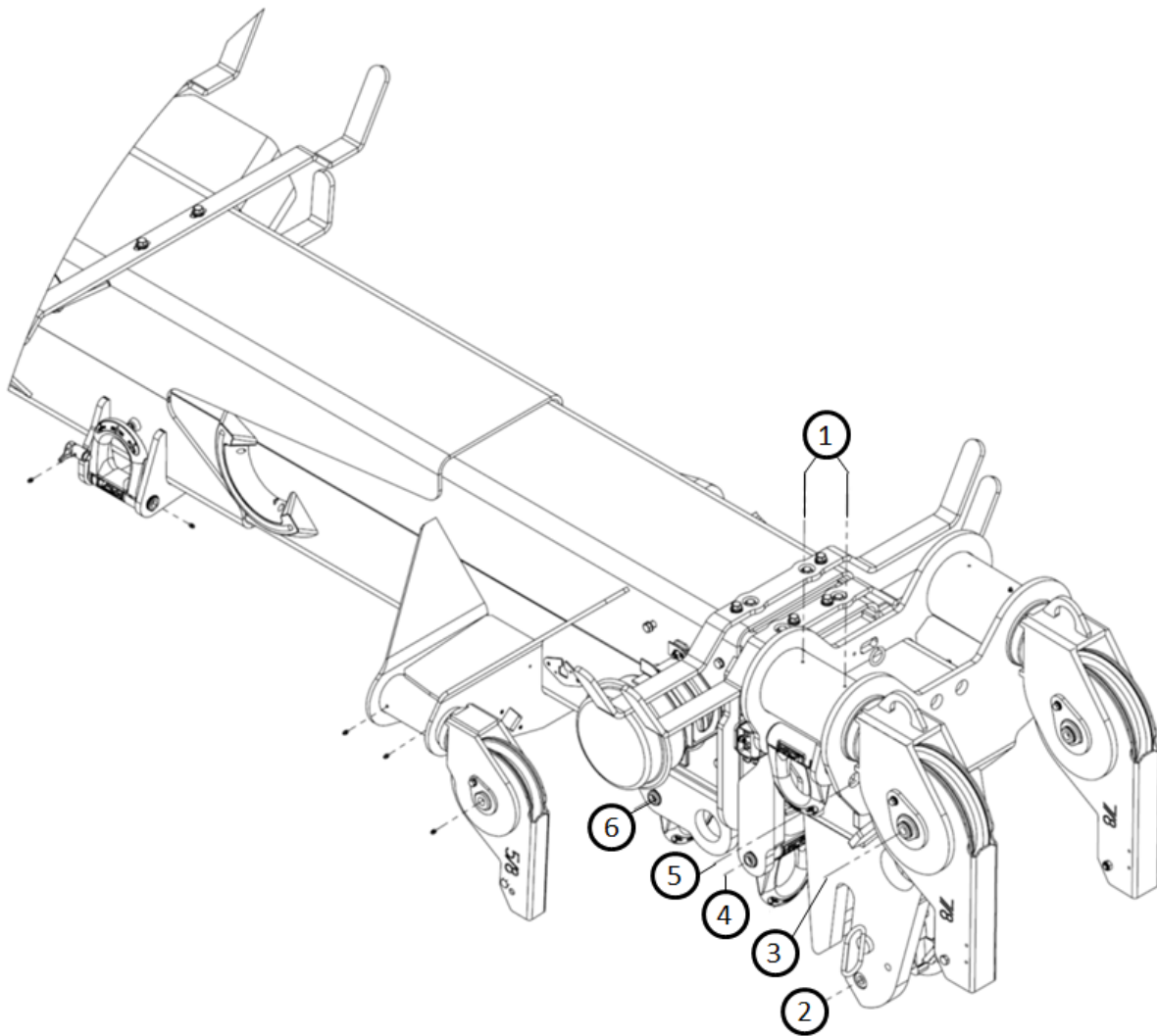

#	Lubrication point	Type
1	Pulley bushing	Grease fitting
2	Underlift locking system	Grease fitting
3	Main winch rotation	Grease fitting
4	D-ring	Grease fitting
5	D-ring	Grease fitting

#	Lubrication point	Type
6	D-ring	Grease fitting

**TABLE 29 – LUBRICATION POINTS - BOOM AND SLIDER BASE**

NOTE: The number of grease fittings may vary depending on your wrecker model.

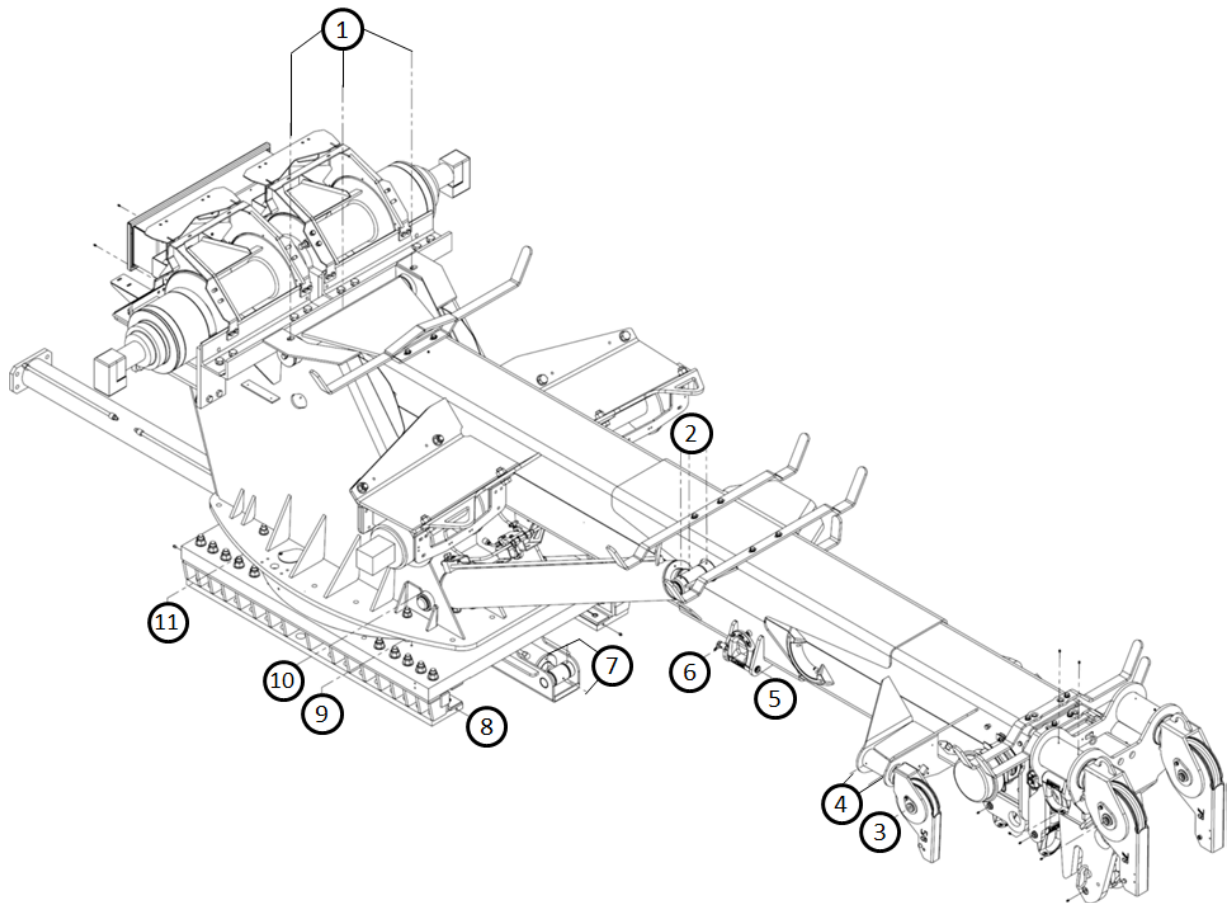

#	Lubrication point	Type
1	Rotation axis of the boom	Grease fitting
2	Lift cylinder anchor point (top)	Grease fitting

#	Lubrication point	Type
3	Auxiliary winch rotation	Grease fitting
4	Pulley bushing	Grease fitting
5	D-ring	Grease fitting
6	D-ring lock	Grease fitting
7	Slider cylinder anchor point	Grease fitting
8	Slider bottom pad	Grease fitting
9	Slider top pad	Grease fitting
10	Lift cylinder anchor point (bottom)	Grease fitting
11	Slider top pad	Grease fitting

**TABLE 30 – LUBRICATION POINTS - SLIDER BASE**

**NOTE:** The number of grease fittings may vary depending on your wrecker model.

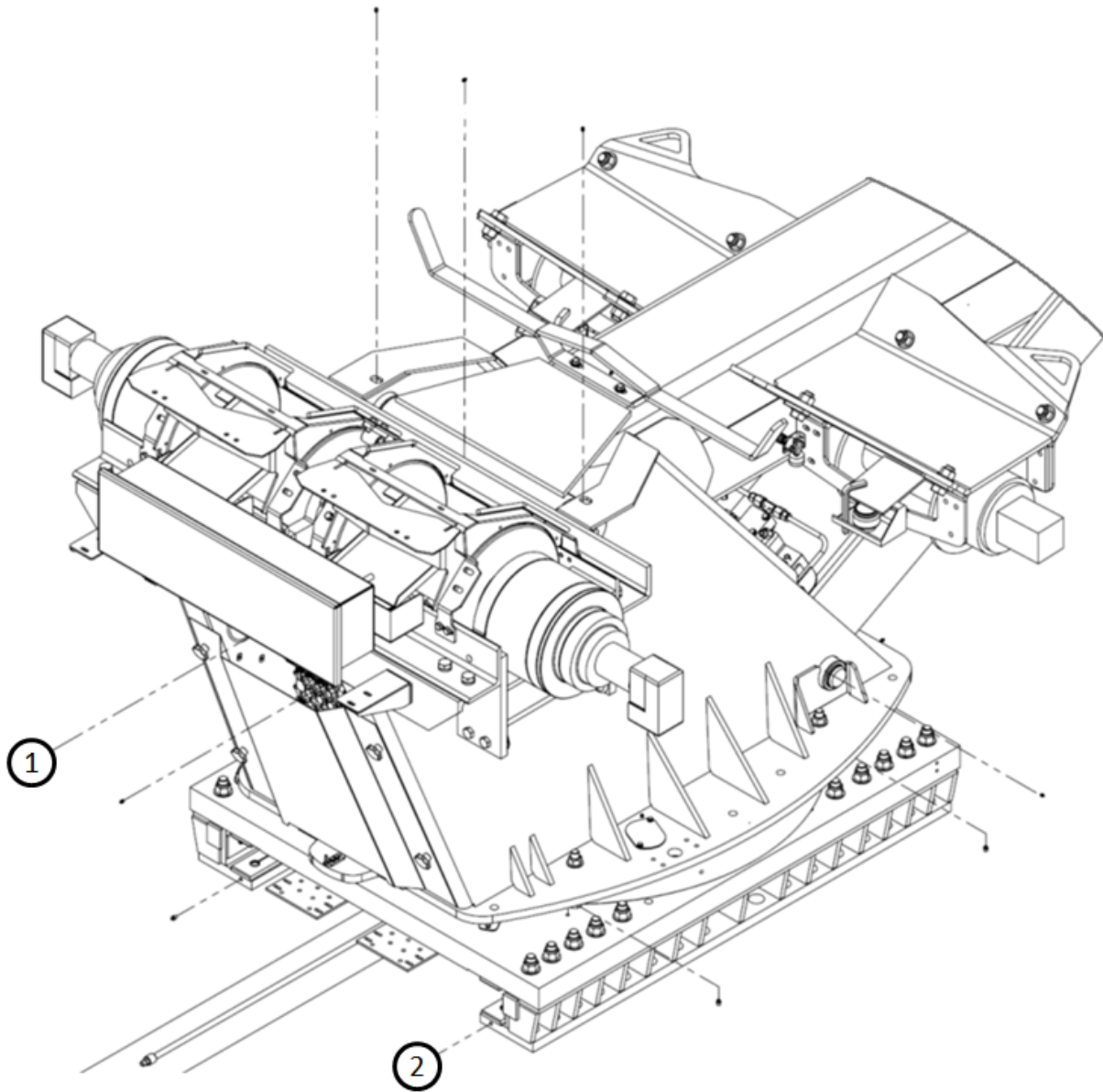

#	Lubrication point	Type
1	Boom extension cylinder anchor point	Grease fitting
2	Slider bottom pad	Grease fitting

## 4.4 Maintenance procedures

This section presents all maintenance procedures.

### 4.4.1 Adjusting the hydraulic pressure (main relief)

#### For the CSR50 and CSR65

The CSR50 and CSR65 have two hydraulic systems: one system for the left side of the wrecker, and one for the right side. Each system has its own hydraulic pump and two hydraulic valves, all inline. As a result, the available hydraulic pressure will be constrained by the element that is providing the least pressure.

For each hydraulic system, the pressure must be adjusted to 3,000 psi (207 bar) for the CSR50, and 3,500 psi (241 bar) for the CSR65. To adjust the pressure of each hydraulic system, you will first need to increase the pressure of each valve to 3,100 psi for the CSR50 or 3,600 psi for the CSR65. If you cannot reach this value by increasing the pressure of the valves, the pump pressure is too low and also needs to be adjusted.

The hydraulic pumps are accessible from under the wrecker.

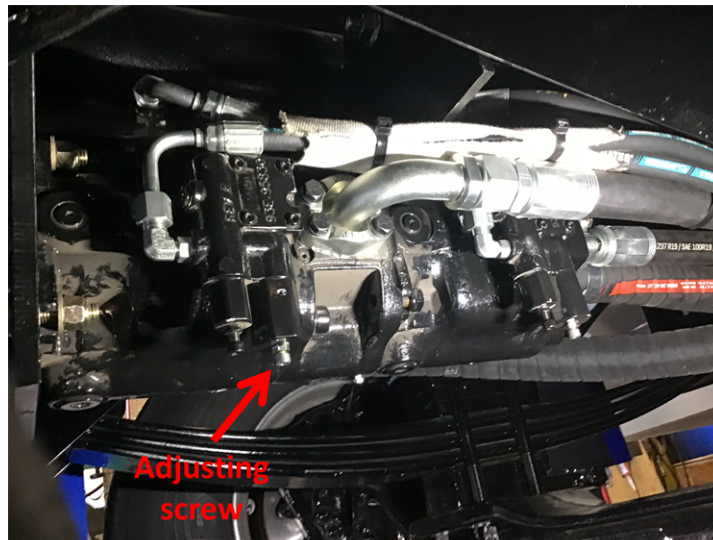

**FIGURE 41 – POSITION OF THE HYDRAULIC PUMP PRESSURE ADJUSTING SCREW (CSR50 AND CSR65)**

There are two valves for each hydraulic system: one in the boom base, behind the steel cover; and one inside the wrecker body, under the wrecker floor.

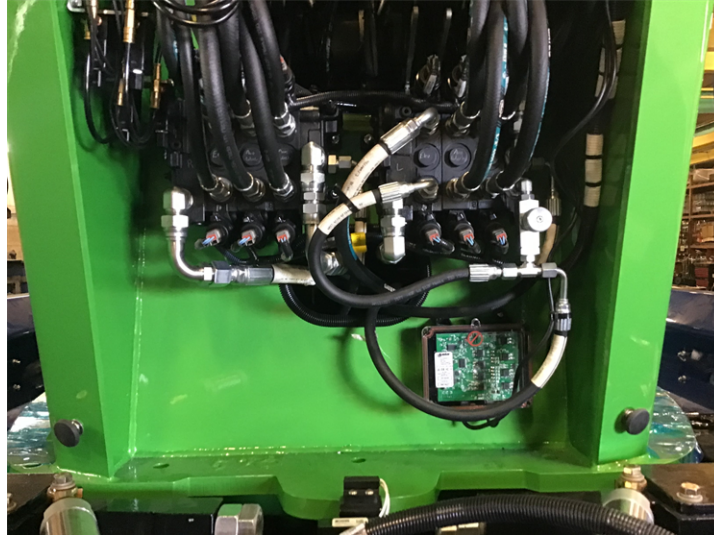

FIGURE 42 – POSITION OF THE VALVES IN THE BOOM BASE (CSR50 AND CSR65)



FIGURE 43 – POSITION OF THE VALVES INSIDE THE WRECKER BODY (CSR50 AND CSR65)

To check the hydraulic pressure of each system:

1. Start the engine and set the engine speed to between 600 and 850 rpm.

NOTE: This is required to obtain an accurate pressure reading.

2. Engage the PTO.
3. Operate the lever that moves the right outrigger up (when the outrigger is already all the way up). On the touchscreen interface, check that the pressure reads 3,000 psi for the CSR50 or 3,500 psi for the CSR65.

NOTE: The pumps are located underneath the truck, near the transmission.

If the pressure is not at the appropriate setting (indicated above) for a hydraulic system, you need to adjust the pressure of both valves in the system as follows:

## NOTICE

**Do not turn the adjusting screw of the relief valve while operating a hydraulic control, as this may permanently damage the valve.**

1. Set the hydraulic pressure to 3,100 psi for the CSR50 or 3,600 psi for the CSR65. To do so :
  - a. slightly loosen the locknut on each valve and turn the adjusting screw on each valve two turns to increase the pressure.
  - b. Re-test the hydraulic pressure as described in step 3 above and check that it reads approximately 3,100 psi for the CSR50 or 3,600 psi for the CSR65. If you cannot reach this value by adjusting the valves, the pump pressure is not high enough. In that case, you need to increase the pump pressure to 3,100 psi for the CSR50 or 3,600 psi for the CSR65 before proceeding with adjusting the valves.

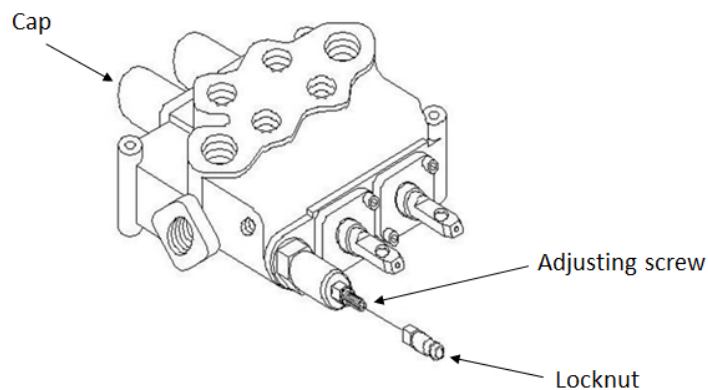

**FIGURE 44 – ADJUSTING THE HYDRAULIC PRESSURE ON THE CSR50 AND CSR65 (MAIN RELIEF)**

2. Unscrew the adjusting screw on each of the valves no more than  $\frac{1}{4}$  turn at a time to decrease the hydraulic pressure until you reach 3,000 psi for the CSR50 or 3,500 psi for the CSR65.
  - a. Re-test the hydraulic pressure after each  $\frac{1}{4}$  turn to ensure that the pressure does not drop below this value. When the pressure reads at 3,000 psi for the CSR50 or 3,500 psi for the CSR65, this means that one of the valves is set to that value, and the other to a value above that.
  - b. On the other valve, Unscrew the adjusting screw no more than  $\frac{1}{4}$  turn at a time to decrease the hydraulic pressure until the pressure drops below the intended value (e.g. 2,900 psi for the CSR50 or 3,400 psi for the CSR65).
  - c. Then screw the adjusting screw back up again until you reach 3,000 psi for the CSR50 or 3,500 psi for the CSR65. At this point, both valves are set to exactly the correct value.
  - d. Tighten both locknuts.

## For the CSR85

The CSR85 has one hydraulic system, which is composed of one hydraulic pump and three hydraulic valves.

To adjust the pressure of the hydraulic system, you first need to adjust the pressure of the pump to 3,970 psi (274 bar). If you cannot reach 3,970 psi, the valves are not adjusted properly, and you should increase their pressure one by one until the pump reaches 3,970 psi.

Next, you need to lower the pressure of each valve, one at a time, below 3,970 psi so that the pump pressure reads 3,800 psi. Then, you need to increase the setting of the valve so that the pump pressure reads 3,970 psi. Lastly, increase the valve pressure over 3,970 psi by turning the adjusting screw  $\frac{1}{2}$  a turn.

When the pump pressure is set to 3,970 psi, the reading for the x-port pressure should be around 3,770 psi. If the reading for the x-port pressure is above 3,770 psi, contact your NRC distributor to correct the problem.

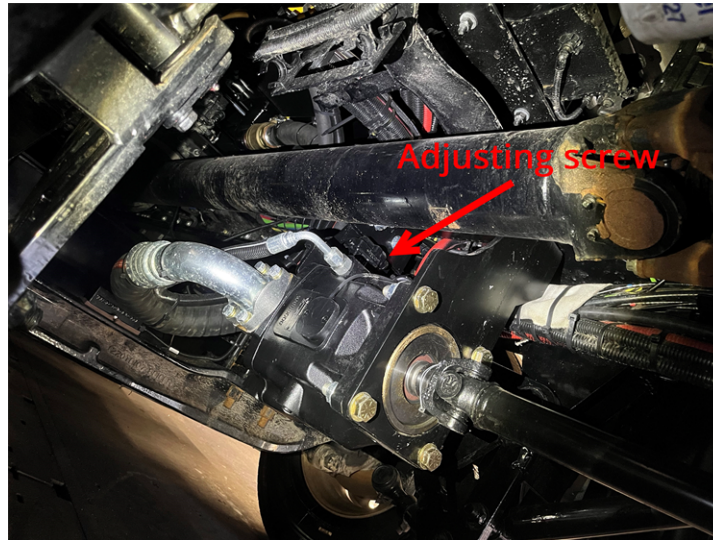

**FIGURE 45 – POSITION OF THE HYDRAULIC PUMP PRESSURE ADJUSTING SCREW (CSR85)**

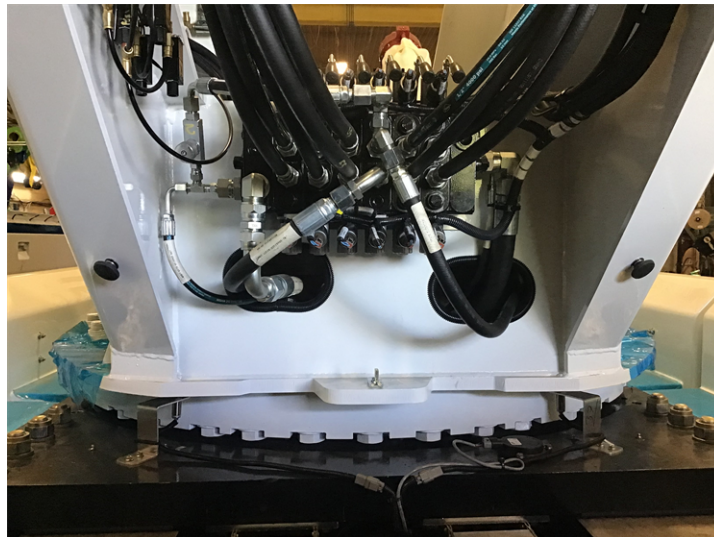

**FIGURE 46 – POSITION OF THE VALVE IN THE BOOM BASE (CSR85)**



**FIGURE 47 – POSITION OF THE VALVES INSIDE THE WRECKER BODY (CSR85)**

To check the hydraulic pressure of each system:

1. Start the engine and set the engine speed to between 600 and 850 rpm.

**NOTE:** This is required to obtain an accurate pressure reading.

2. Engage the PTO.
3. Operate the lever that moves the right outrigger up (when the outrigger is already all the way up). Check that the pump pressure reads 3,970 psi on the touchscreen interface and that the x-port pressure is 3,770 psi.

**NOTE:** The pumps are located underneath the truck, near the transmission.

Then, adjust the pressure of the three valves as follows:

## NOTICE

**Do not turn the adjusting screw of the relief valve while operating a hydraulic control, as this may permanently damage the valve.**

1. For each of the three valves:
  - a. Slightly loosen the locknut on each valve and screw the adjusting screw two turns to increase the pressure.
  - b. Re-test the hydraulic pressure as described in step 3 above and check that it reads above 3,970 psi. If you cannot reach 3,970 psi by adjusting the valves, the pump pressure is not high enough. In that case, you need to increase the pump pressure to 3,970 psi before proceeding with adjusting the valves. To do so, screw the adjusting screw on the pump to increase the pressure.

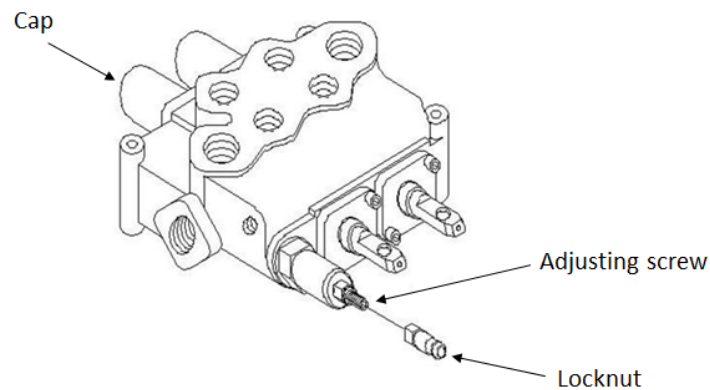

**FIGURE 48 – ADJUSTING THE HYDRAULIC PRESSURE ON THE CSR85 (MAIN RELIEF)**

2. One valve at a time:
  - a. Unscrew the adjusting screw on the valve to decrease the hydraulic pressure until you reach 3,800 psi.
  - b. Re-test the hydraulic pressure after each  $\frac{1}{4}$  turn to ensure that the pressure reaches 3,800 psi.
  - c. Once the pressure reads 3,800 psi, turn the adjusting screw  $\frac{1}{4}$  turn at a time and re-test the pressure until it reaches 3,970 psi.
  - d. Add  $\frac{1}{2}$  turn. Tighten both locknuts. Repeat for the two other valves.

#### 4.4.2 Adjusting the counterbalance valves (CBCG-LJN)

The wrecker has ten counterbalance valves, which are all adjusted with the same adjustment: Completely screw and then unscrew  $3\frac{3}{4}$  turns.

- Two are used to control the pressure of the boom in/out cylinder. They are located inside the boom.
- Two are used to control the pressure of each outrigger's up/down cylinder. They are located above each outrigger up/down cylinder.

(missing or bad snippet)

1. Loosen the jam nut.

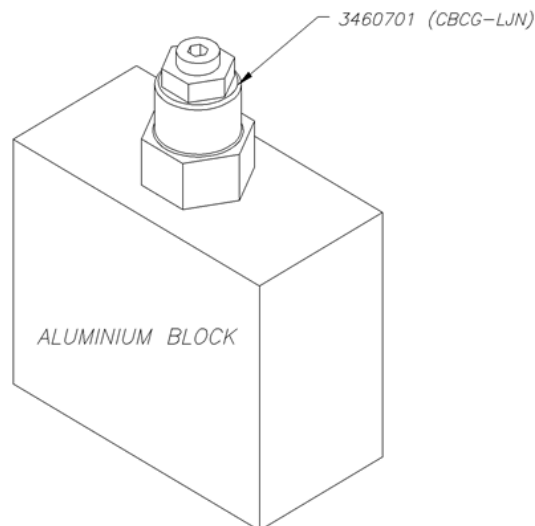

FIGURE 49 – ADJUSTING THE COUNTERBALANCE VALVE (CBCG-LJN)

2. Turn the set screw clockwise until it stops.
3. Turn the set screw counter-clockwise to the appropriate setting (described above) and keep the screw in this position while you tighten the jam nut.

**NOTE:** Position the Allen key so you can easily count how many turns you make when setting the screw.

#### 4.4.3 Adjusting the sequence valve (SCCA-LAN)

The wrecker has one sequence valve, which is located in the boom (shown below). This valve ensures that the medium section of the boom is extended before the smaller section.



**FIGURE 50 – SEQUENCE VALVE POSITION**

Adjustment: Completely unscrew and then screw 4.5 turns.  
(missing or bad snippet)

1. Loosen the jam nut.

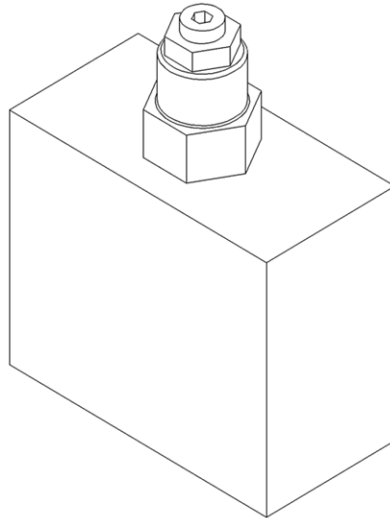

**FIGURE 51 – ADJUSTING THE SEQUENCE VALVE (SCCA-LAN)**

2. Turn the set screw counter-clockwise until it stops.
3. Turn the set screw clockwise to the appropriate setting (described above) and keep the screw in this position while you tighten the jam nut.

**NOTE:** Position the Allen key so you can easily count how many turns you make when setting the screw.

#### **4.4.4 Adjusting the rotation motor relief valves (RV3A)**

The wrecker has two relief valves for the rotation lock: one for the clockwise rotation and another for the counterclockwise rotation. These relief valves protect the swing drive by limiting the pressure. They are located on the swing drive motor.

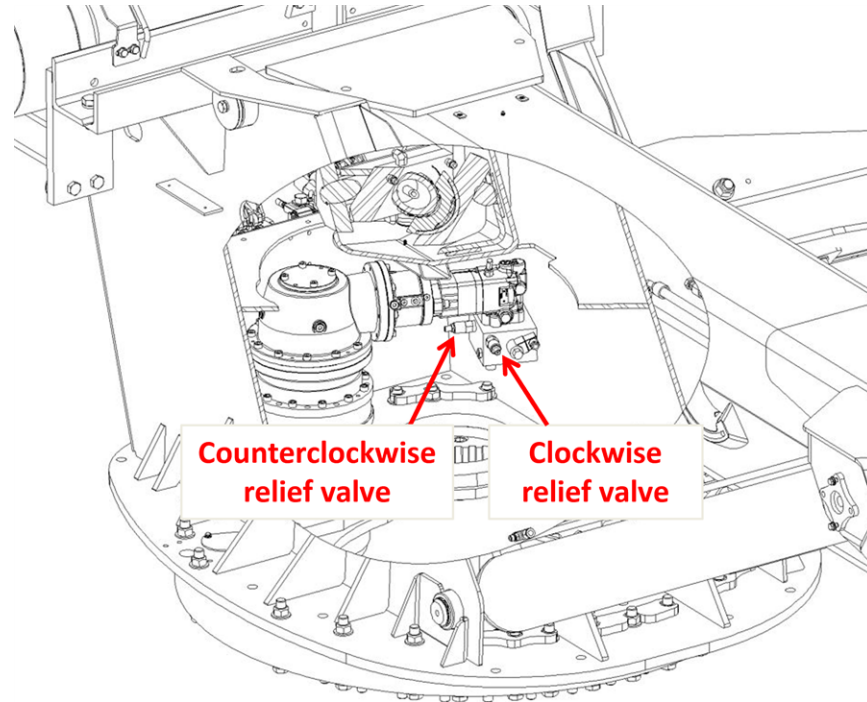

**FIGURE 52 – POSITION OF THE ROTATION MOTOR RELIEF VALVES**

This procedure should only be performed by your NRC distributor.

Adjustment: 2,000 psi (138 bar).

1. Start the engine and set the engine speed to between 600 and 850 rpm.

**NOTE:** This is required to obtain an accurate pressure reading.

2. Engage the PTO.
3. Lock the boom rotation.
4. Operate the rotation control. Read the pressure on the touchscreen interface and check that it is at the appropriate setting (specified above). Release the hydraulic control.

5. If the pressure is not at the appropriate setting (described above), unscrew the valve locknut and turn the adjusting screw no more than  $\frac{1}{4}$  turn at a time. Test the hydraulic pressure and continue making adjustments until it is correct. Tighten the locknut.(missing or bad snippet)

#### 4.4.5 Adjusting the underlift cushioning valve

The underlift cushioning valve is located inside the top rear section of the frame, under the aluminium cover. Should you have problems folding or unfolding the underlift, you may have to adjust the valve. The **B+A** cartridge controls the folding, and the **C+D** cartridge controls the unfolding. Both cartridges need to be set to 2,000 psi (138 bar). Ensure that the hoses are as shown in the following figure.

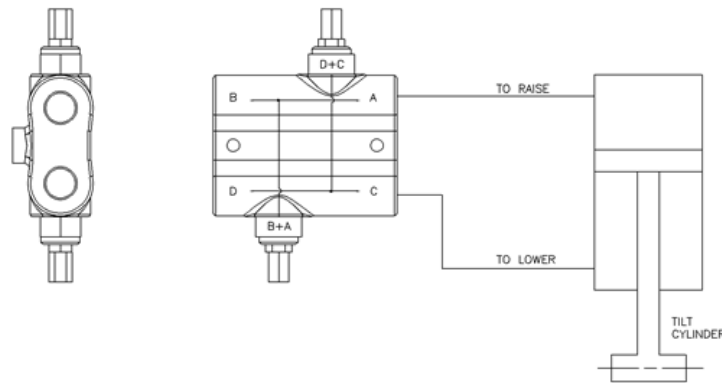

FIGURE 53 – ADJUSTING THE UNDERLIFT CUSHIONING VALVE

1. Completely unfold the underlift.
2. Completely retract the underlift (extension).
3. Try folding the underlift. If it can be folded easily, the cushioning valve is correctly adjusted. If not, continue to the next step.

4. Unscrew the locknut.

NOTE: Make sure to choose the appropriate cushioning valve.

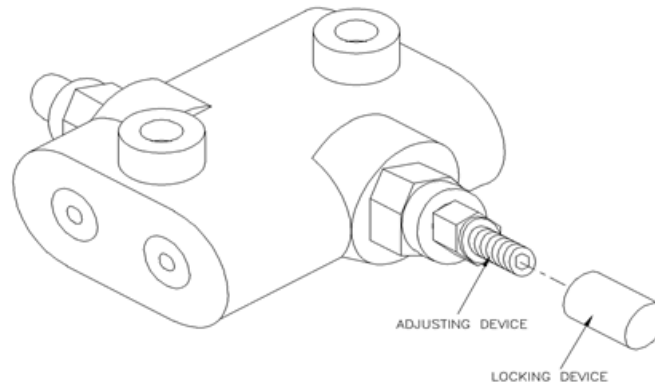

FIGURE 54 – ADJUSTING THE CUSHIONING VALVE

5. Turn the adjusting screw no more than  $\frac{1}{4}$  turn at a time. (missing or bad snippet)
6. Try folding up the underlift. If it still lacks power, repeat Step 5 until the underlift folds correctly. Do not apply excessive pressure; use the minimum required to fold it correctly.
7. Tighten the locknut.

#### 4.4.6 Aligning the boom

IMPORTANT: Lock the sliding rotator before checking the boom alignment.

##### Check the boom alignment

1. Slowly place the boom in the centre of the underlift rails at the rear of the body until it locks into place.

2. Verify that the boom is centred using the following steps:
  - a. Visually verify that the boom is centred. You can also place a straightedge on the boom and measure each side.
  - b. On the touchscreen interface, verify that the indicator sensor shows that the boom is centred. If the indicator sensor does not show that the boom is centred, adjust the sensor's position so that it detects the boom.
  - c. After the indicator sensor is adjusted and is able to detect that the boom is centred, visually verify again that the boom is centred.
3. If the boom is out of alignment, align it as follows.

### **Align the boom by adjusting the screws on the front locks**

1. Loosen the locknuts securing the adjustment bolts.
2. Screw the bolts in or out. Tighten the locknuts.

## **4.4.7 Disassembling the outriggers**

### **For the CSR50**

#### **Disassembly**

1. Extend the outrigger and stop when the small section (#4) is extended approximately 10-15 inches so you can access the steel shims (#14) of the middle section (#5).
2. Remove the steel shims (#14) and the bottom nylon pad (#6) of the middle section.
3. Support the small section with an appropriate tool.

## **⚠ CAUTION**

**Make sure to properly support the small section during disassembly. It is heavy and may cause damage or injury if it is unsupported and falls to the ground.**

4. Remove the snap ring (#27) and the pin (#11) that hold the cylinder to the small section. Retract the cylinder completely. The small section will come apart from the middle section.

5. Slightly lower the small section so you can access to the top nylon pads (#7) of the middle section. Remove the top nylon pads.
6. While still supporting the small section, completely remove it from the middle section. You may have to jiggle the small section to remove it. Carefully place the small section on the ground.
7. Support the middle section with an appropriate tool. Repeat the previous steps to remove the middle section from the large section. Carefully place the middle section on the ground.
8. Replace all the nylon pads of all the sections.

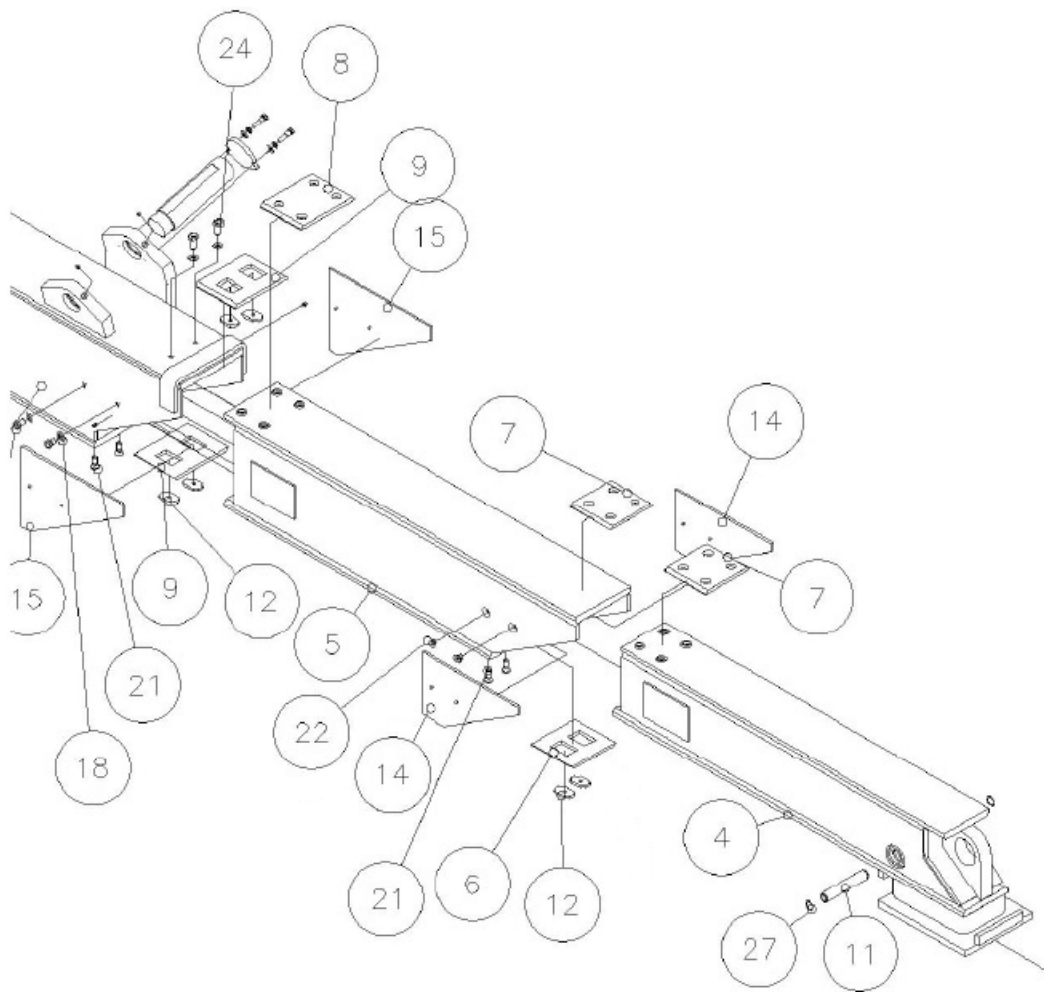

**FIGURE 55 – DISASSEMBLING THE OUTRIGGER (CSR50)**

## Reassembly

To reassemble the outrigger, reverse the disassembly procedure.

## For the CSR65 and CSR85

### Disassembly

1. Extend the outrigger and stop when the small section (#1) is extended approximately 10-15 inches so you can access the steel shims (#3) of the middle section (#2).
2. Remove the steel shims (#3) of the middle section and the nylon pads (#4) of the small section. If you can, completely remove the steel shims and nylon pads. If you cannot remove the shims, extend the outrigger to facilitate the removal.
3. Remove the snap ring and the pin (#6) that hold the cylinder to the large section (#7).
4. Disconnect both hydraulic hoses from the cylinder.
5. Support the small section (#1) with an appropriate tool.
6. Completely remove the small section (#1) from the middle section (#2). Since the small section is still attached to the cylinder, remove the cylinder with the small section. Carefully place the cylinder and small section on the ground.

## CAUTION

**Make sure to properly support the small section during disassembly. It is heavy and may cause damage or injury if it is unsupported and falls to the ground. Support the outrigger according to the centre of gravity, which will move while you remove the small section.**

7. Support the middle section (#2) with an appropriate tool. Remove the steel shims and nylon pads of both the large and middle sections.
8. Remove the middle section (#2) from the large section (#7). Carefully place the middle section on the ground.
9. Replace all the nylon pads of all the sections.

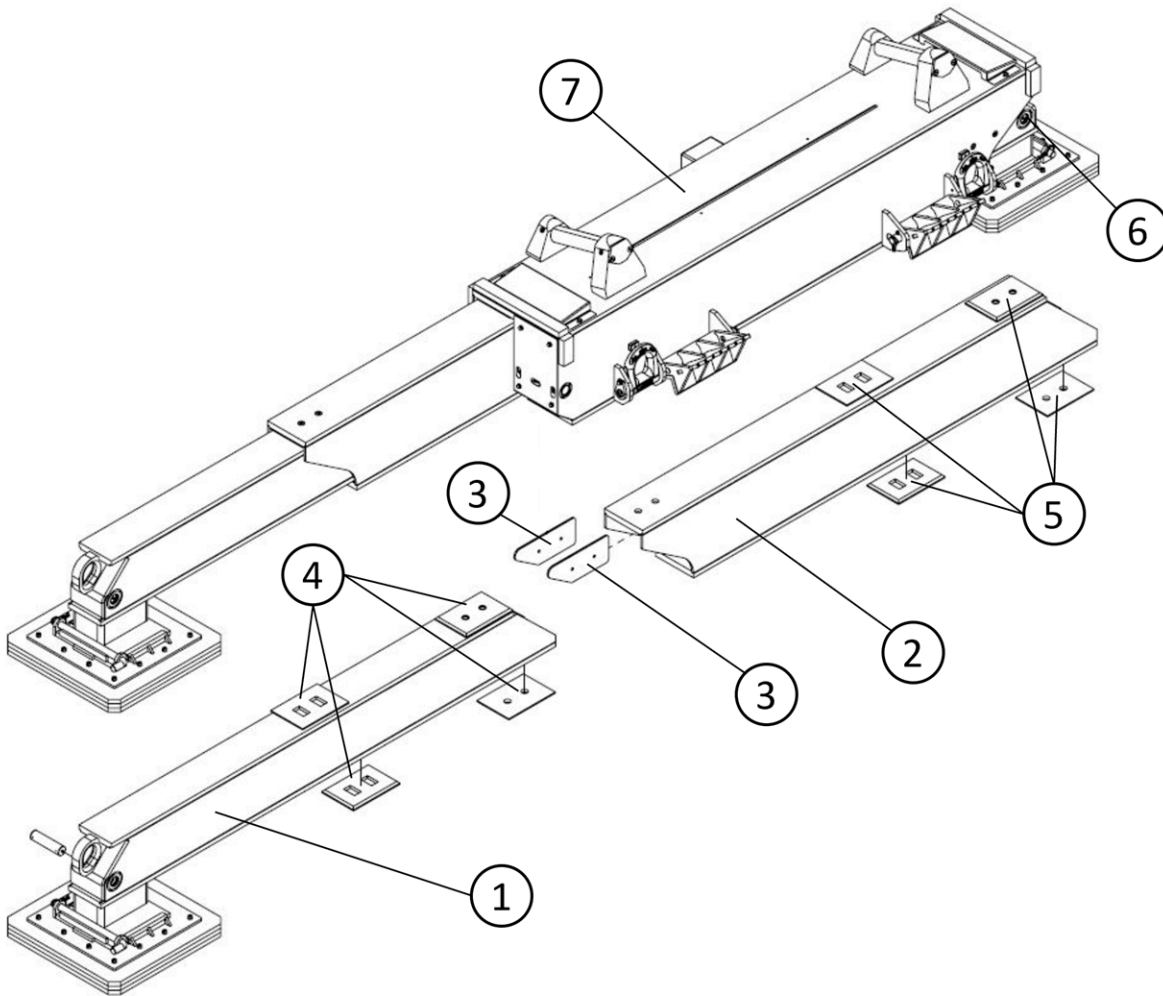

FIGURE 56 – DISASSEMBLING THE OUTRIGGER (CSR85)

### Reassembly

To reassemble the outrigger, reverse the disassembly procedure.



## 5 TROUBLESHOOTING

This chapter provides a summary of the most common problems, their main causes and solutions. The following sections provide detailed procedures for some of the solutions.

**NOTE:** Only distributors are authorized to perform repairs that involve replacing parts.

## 5.1 Troubleshooting common problems

The following table covers problems that you can solve on your own. If your problem is not listed or you cannot resolve it yourself, contact your distributor.

The list of authorized distributors and service providers is attached.

TABLE 31 - TROUBLESHOOTING

Problem	Causes	Solutions
The levers on the left-hand side control panel don't work	The remote control switch is in the remote control position	Set the remote control switch to the control panel (not remote control) position.
	The PTO is not engaged	Engage the PTO.
	The control panel has no power	Check the DC power (12 VDC in North America and 24 VDC elsewhere) on the main electrical panel (main relay) and check the control panel wiring.
	There is no hydraulic power	Check whether the right-hand side control panel is working. If not, troubleshoot the hydraulic system.
The winches cannot be engaged	The air pressure is too low	Check for an air leak or a bent hose.

Problem	Causes	Solutions
The winches cannot be disengaged	The solenoid has no power	Using a multimeter, see whether the solenoid wiring is carrying a current.
	The air pressure is too low	Check for an air leak or a bent hose.
	The winch solenoid is faulty	Replace the solenoid. Follow the air line to locate the solenoid, which is near the winch.
	The cylinder piston may be broken or bent (only for RPH 15000 winches)	Replace the cylinder.
The wrecker lacks power and runs too slowly	The hydraulic pump is faulty	Check and adjust the hydraulic pressure (see Section 4.4.1 Adjusting the hydraulic pressure (main relief)).
The control panel doesn't show whether the boom is centred	The sensor is not detecting the position of the boom	Move the boom all the way to the front of the wrecker to ensure that it can be detected by the sensor.
	The boom position sensor is faulty or absent	Replace the sensor. It is located in the centre (left-right) of the wrecker, on the structure retaining the rotation lock. To access it, move the sliding rotator to the rear of the wrecker.
The winch cable stops too quickly or too slowly in free spool mode (disengaged)	The air pressure on the cable tensioner is too low or too high	Increase or decrease the air pressure on the cable tensioner. The regulator is located between the two main winches. This is a trial and error adjustment. Keep adjusting the air pressure of the cable clamp balloon until you find the right setting.

Problem	Causes	Solutions
DP winch only: The drag winch cable stops too quickly or too slowly in free spool mode (disengaged)	The drag brake pad is broken or worn out.	Replace the pad.
The wrecker has no power	The ignition doesn't send a signal to the solenoid telling it to activate	Check the power and ensure that the solenoid is properly grounded. Replace any damaged wiring.
	The main solenoid is burned out	Replace the main solenoid in the main electrical panel.
The sliding rotator lacks power when rotating	The rotation valves are not adjusted properly.	Adjust the rotation relief valves (see Section 4.4.4 Adjusting the rotation motor relief valves (RV3A)).
The sliding rotator won't unlock	The solenoid air pressure is too low	Check for an air leak or a bent hose.
	The solenoid wiring is damaged	Check the power and ensure that the solenoid is properly grounded. Replace any damaged wiring.
	The solenoid is burned out	Replace the solenoid. It is located behind the control panel on the right-hand side.
	The locks are jammed	Clean and grease the locks.
	The lock cylinders are damaged	Replace any damaged cylinders.

Problem	Causes	Solutions
The underlift is difficult to fold or unfold	The cushioning valve is not adjusted properly	Adjust the cushioning valve (see Section 4.4.5 Adjusting the underlift cushioning valve).
	The pivot pin is jammed	Clean and grease the pin.
One or more underlift extensions have trouble retracting	The hydraulic pressure is too low	Check the hydraulic pressure (see Section 4.4.1 Adjusting the hydraulic pressure (main relief)).
	The spool on the valve bank is not completing its stroke	Check the neighbouring spool and ensure that the spool completes its stroke. If the spool does not complete its full stroke, something is preventing it from moving freely. Remove the obstruction.
	The wear pads are not in place or sufficiently lubricated	Ensure that all wear pads are in place and well lubricated.
	One or more underlift sections are bent	Use a straight edge to see whether all the underlift sections are straight. If one is bent, have it repaired. You can also remove the steel spacers one by one and see whether that makes a difference.
	The IN/OUT cylinder is diverted	Completely retract the cylinder. Disconnect the very bottom hose from the tail board. Remove the male quick coupler from the hose and put the open end of the hose in a pail. Start the hydraulic system and pull the lever to retract it again, even if it is already retracted. If oil comes out of the hose in the pail, something is wrong with the cylinder. Have it repaired.

Problem	Causes	Solutions
The remote control won't control the equipment	The remote control battery is dead	Recharge the battery. The battery charger is inside the left-hand side control panel.
	The wrecker is being controlled by the control panel	Use the touchscreen interface to activate remote control mode.
	The antenna on the remote control receiver is broken	Replace the antenna. It is located on the right side of the wrecker, just above the oil reservoir.
The boom lowers on its own	The holding valves are not adjusted properly	Adjust the holding valves.
	Rubber or silicone particles in the hydraulic fluid are stuck in the holding valves or cartridges	Fully lower the boom. Loosen the nut that locks the set screw on the cartridge. Turn the set screw clockwise until it stops. This opens the valve completely. Fully retract and extend the boom several times. This flushes the cartridge and may release the particles. Adjust the cartridge (see Section 4.4.2 Adjusting the counterbalance valves (CBCG-LJN)). Try the boom again to see whether the problem is solved.
	The cartridge is faulty	Replace and adjust the cartridge (see Section 4.4.2 Adjusting the counterbalance valves (CBCG-LJN)).
	The boom cylinder is faulty	Check the boom cylinder and have it repaired or rebuilt (see Section 5.2 Checking the boom cylinder).

Problem	Causes	Solutions
The smaller sections of the boom extend before the larger sections	The sequence valve is not adjusted properly	Adjust the sequence valve (see Section 4.4.3 Adjusting the sequence valve (SCCA-LAN)).
The boom extends by itself with a load on the underlift or retracts by itself with a load on the winch cables	There is an external oil leak	Repair any external oil leaks.
	The counterbalance valve is not adjusted properly	Adjust the counterbalance valve (see Section 4.4.2 Adjusting the counterbalance valves (CBCG-LJN)).
	The boom cylinder is faulty	Check the boom cylinder and have it repaired or rebuilt (see Section 5.2 Checking the boom cylinder).
The levelling system does not level the wrecker correctly	The outriggers do not touch the ground	Ensure that ONLY the outrigger feet touch the ground.
	The levelling system is not calibrated	For wreckers with a display, recalibrate the levelling system in the display (see the manual for your touchscreen model).
Sensor problems (displayed on the touchscreen interface)	The sensor is not calibrated properly	Adjust the sensor in the touchscreen interface (see the manual for your touchscreen model).

## 5.2 Checking the boom cylinder

You need to check the boom cylinder if the boom:

- Retracts by itself when lifting a (heavy) load with the winches.
- Extends by itself when lifting a load on the underlift. The underlift tilts down when the boom extends.

The problem might be due to a leaking piston, damaged seal or broken cartridge in the lock valve block.

The following troubleshooting procedure isolates a boom cylinder and checks it for leaks. If you push oil onto one side of a cylinder and the other side is vented, no oil should leak unless there is a broken piston, damaged seal or broken cartridge.

**NOTE:** You will need a load (e.g. another vehicle) for this procedure.

1. Lower the underlift completely.
2. Choose a lifting point on the vehicle to be towed. It must be both strong enough and have enough clearance for the underlift to move.

### DANGER

**Using a poor lifting point may damage the towed vehicle and wrecker or even cause a serious accident.**

3. Use the safety chains and tensioner to hold the vehicle in place on the underlift's T-bar.
4. Fully retract the boom and keep it retracted using a winch cable hooked to the D-ring on your wrecker.
5. Stop the hydraulic system.
6. Disconnect the two hoses coming from the bottom of the square bushings at the end of the boom cylinder rods.
7. Put a cap on the ends of each hose. This prevents the oil from leaving the cylinder through the hoses.

8. Start the hydraulic system.
9. Disengage the winch that is keeping the boom retracted. If the boom does not stay retracted, the cylinder has to be rebuilt or replaced.



## 6 ACCIDENT OR BREAKDOWN PROCEDURE

This section explains what to do in case of an accident or equipment failure. Your goal is to safely stabilize the equipment and either perform the necessary repairs on site or bring it to a repair location.

Refer to this manual for all operation, maintenance and repair procedures. If in doubt, do not hesitate to contact your distributor. See the list of Authorized distributors and service providers.

### 6.1 Electrical failure

In the event of an electrical failure, you can use the manual hydraulic levers to safely stabilize the equipment.

#### **⚠ WARNING**

**The electrical failure must be repaired before performing other towing operations. Contact your distributor to correct the problem.**

### 6.2 Hydraulic failure

In the event of a hydraulic failure, the hydraulic pressures required for normal operation are not reached in the circuits. The hydraulic pump or PTO may be the cause.

#### **⚠ WARNING**

**The hydraulic failure must be repaired before performing other towing operations.**

To troubleshoot a hydraulic failure:

1. Using a component that requires hydraulic pressure (e.g. the boom), check whether the hydraulic pressure shows as normal on the display.
2. Engage the PTO to operate the hydraulic pump and check the display to see whether the PTO engages normally. If the PTO does not engage, have it repaired

3. If the PTO works normally, check whether the hydraulic pump is operating normally. If the hydraulic pump is not working normally, see Pump Failure below.

When the correct operating pressures are reached, stabilize the equipment safely.

## 6.3 Pump failure

In the event of a pump failure, the entire hydraulic system will not be functional. If all hydraulic components (boom, outriggers, etc.) are in their stored position, i.e. the position for travel without a load, bring your equipment to a repair location. If some components are not in their stored position, and it is not possible to safely get to a repair point, the pump must be repaired or replaced on site.

## 6.4 Truck failure

In the event of a vehicle breakdown, you will not be able to operate the equipment. Have the equipment moved to a safe place to make the necessary repairs on the truck.

## 6.5 Underlift stinger failure

In the event of an underlift stinger failure in which the stinger can no longer be extended or retracted, the most probable cause is a bent cylinder. Remove the underlift and have it repaired.

## 7 STORAGE

Proper storage is important to prevent premature wear and tear on your machine. Ideally, it should be stored in a dry, covered area.

When storing your wrecker:

1. Immobilize the machine in a dry and stable location.
2. As per Section 4.3 Lubrication, lubricate all parts, including the slider.
3. Position the parts so that the cylinders are fully retracted.
4. Lubricate any exposed cylinder rods.
5. Disconnect the electrical power supply to avoid depleting the batteries.

When taking your wrecker out of storage:

1. Clean and lubricate all parts, including the slider.
2. Replace the high-pressure and return filters on the hydraulic reservoir.
3. Check the oil level and pressure.
4. Connect the electrical power supply.



## 8 DISASSEMBLY AND DISPOSAL

When the equipment reaches the end of its lifespan, dispose of its various parts in an environmentally friendly manner.

Before disassembling the machine, drain all fluids and remove the battery for recycling.

Comply with all effective regulations, including the RoHS Directive for electrical components, when disassembling the machine and disposing of the following parts:

- Electrical components;
- Rubber hydraulic hoses;
- Painted parts;
- Metal;
- Composite materials.

To protect both you and the environment, we recommend having a specialized company disassemble your machine.



## 9 ACCESSORIES

There are many towing accessories available to fit most of your towing requirements. This section presents the most common types of accessories available. Contact your NRC distributors to learn more about the full range of accessories available for your wrecker model.

## 9.1 Forks and fork holders

Forks are components used with fork holders. They are installed on the T-head of the T-bar and can be used to hold the vehicle towed by the chassis, axles or structural members.

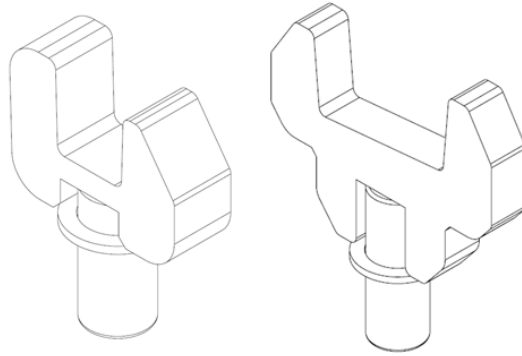

FIGURE 57 – EXAMPLE OF FORKS

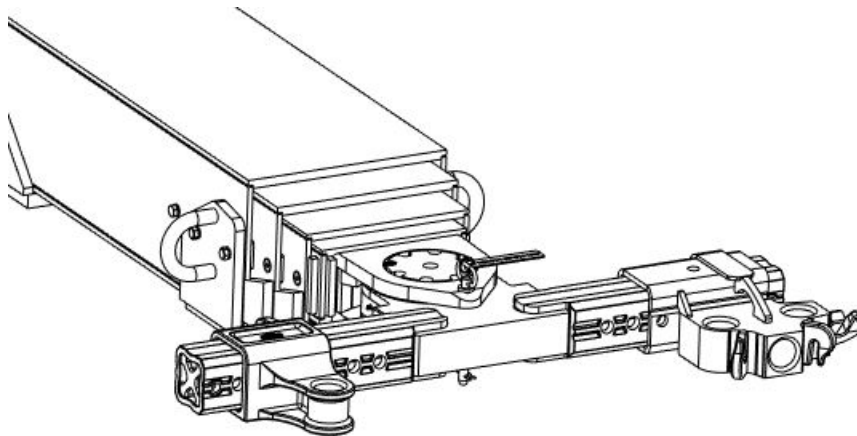

FIGURE 58 – EXAMPLE OF FORK HOLDERS

### 9.1.1 How to use forks and fork holders

Install the fork holders on the T-head of the T-bar. There are several positions in which they can be installed.

1. Position the fork holders on the T-head of the T-bar.
2. Secure them in place using the integrated locking system or pin provided.
3. Install the fork in the fork holder.

Once in place, position the axle (or chassis or other structural members) of the towed vehicle on the forks, then secure the vehicle in place.

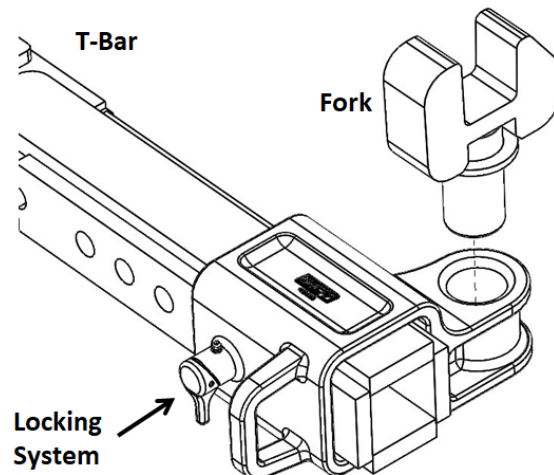

**FIGURE 59 – INSTALLING THE FORKS AND FORK HOLDERS**

## 9.2 Holders with integrated forks

HOLDERS with integrated forks are accessories that also fit into the T-head of the T-bar. They combine both the fork holder and the fork in one accessory. They serve as a direct link between the towed vehicle and the T-bar. They can be used in place of the fork holders and forks.

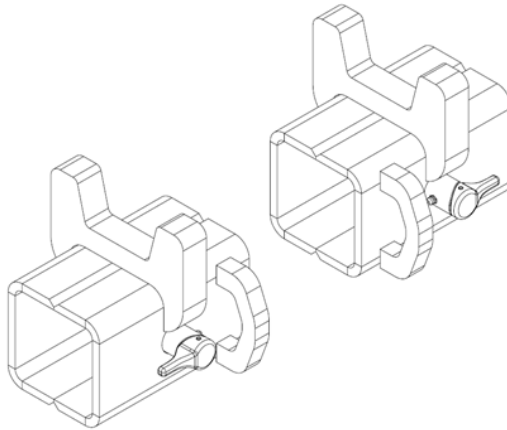

FIGURE 60 – EXAMPLE OF HOLDERS WITH INTEGRATED FORKS

### 9.2.1 How to use holders with integrated forks

Install the holders with integrated forks on the T-head of the T-bar. There are several positions in which they can be installed.

1. Position the holders with integrated forks on the T-head of the T-bar.
2. Secure them in place using the integrated locking system.

Once they are in place, position the axle (or chassis or other structural members) of the towed vehicle on the forks, then secure the vehicle in place.

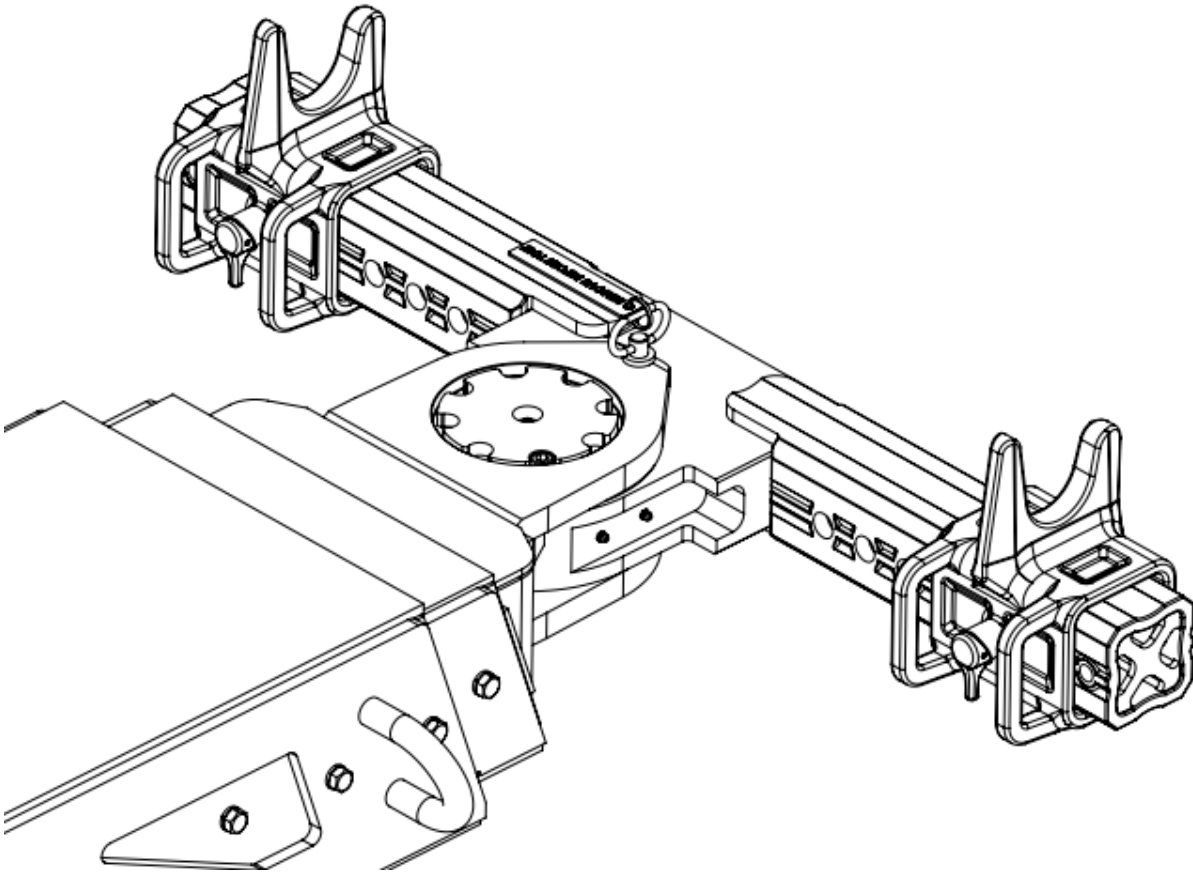

FIGURE 61 – EXAMPLE OF HOLDERS WITH INTEGRATED FORKS

## 9.3 T-bar brackets

T-bar brackets are accessories that also fit into the T-head of the T-bar. They are used to attach the towed vehicle with tow chains to the T-bar, thereby securing the vehicle during towing.

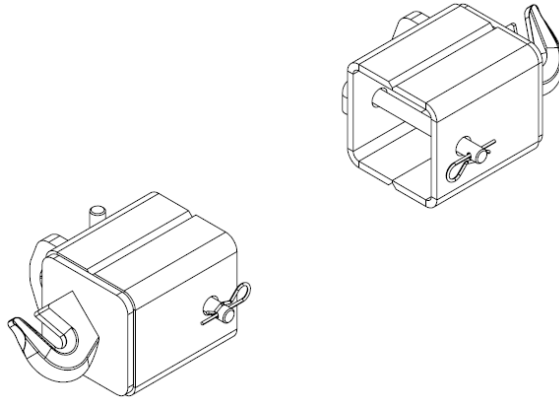

FIGURE 62 – EXAMPLE OF T-BAR BRACKETS

### 9.3.1 How to use T-bar brackets

Install the T-bar brackets on the T-head of the T-bar. There are several positions in which they can be installed to adapt to the towed vehicle.

1. Position the T-bar brackets on the T-head of the T-bar.
2. Secure them in place using the locking pin.

Once they are in place, position the axle (or chassis or other structural members) of the towed vehicle on the T-bar, then secure the vehicle in place. To do so, attach the axle of the vehicle to the hooks of the T-bar brackets using tow chains.

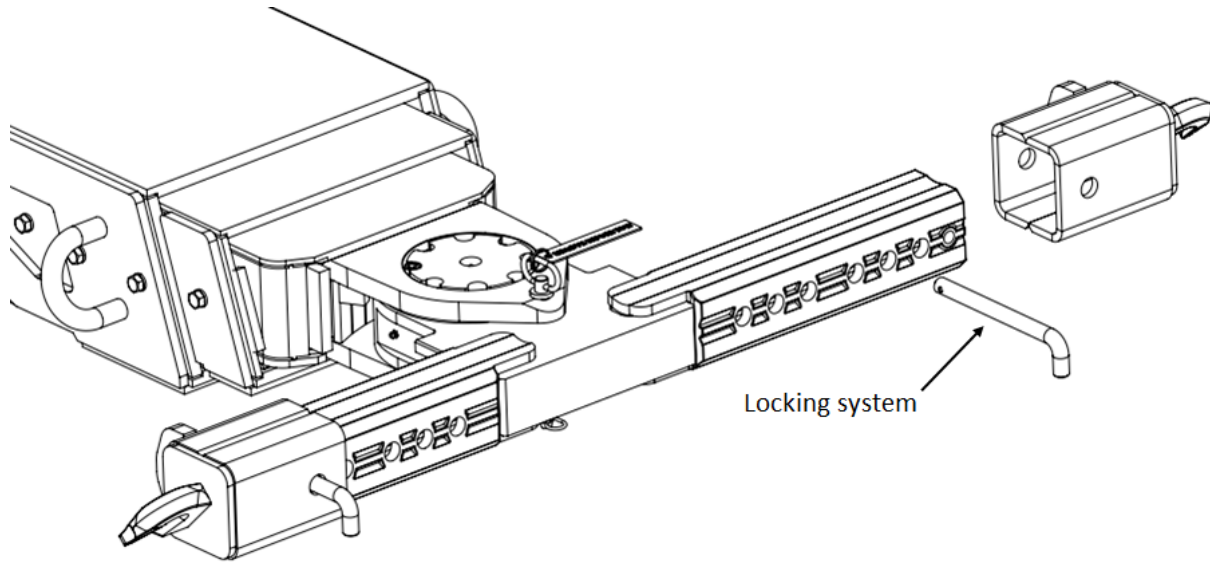

FIGURE 63 – INSTALLING THE T-BAR BRACKETS

## 9.4 Heavy duty tire lifts

Heavy duty tire lifts (commonly known as bus brackets) are used to tow heavy vehicles. They have a capacity of 5,440 kg (12,000 lb.). These accessories are installed on the T-head of the T-bar and are secured in place with locking pins. They can be installed at different positions on the T-head of the T-bar to fit vehicles of different widths. The positions of the angled plates can also be adjusted to fit different wheel sizes.

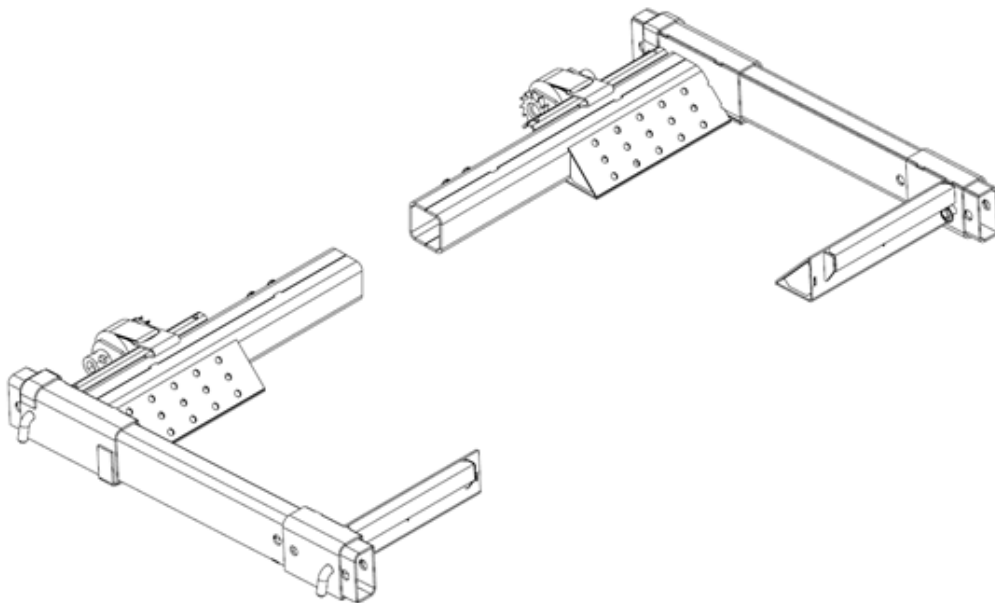

FIGURE 64 – EXAMPLE OF HEAVY DUTY TIRE LIFTS

### 9.4.1 How to use heavy duty tire lifts

The heavy duty tire lifts fit directly on the T-head of the T-bar and are secured in place with a locking pin.

1. Position the heavy duty tire lifts at the appropriate position on the T-head of the T-bar. Make sure to position the tire lifts appropriately for the dimensions of the vehicle to be towed.
2. Secure both heavy duty tire lifts in place using the locking pins.
3. Position the angled plates to fit the wheel dimensions of the vehicle to be towed.
4. Secure each angled plate in place using the locking pin.

Once the heavy duty tire lifts are installed, load the vehicle on the brackets and secure the vehicle in place.

1. Position the wheels of the vehicle on the angled plates.
2. Use straps to secure the vehicle in place. These go around the tire and attach to the back of the tire lifts.

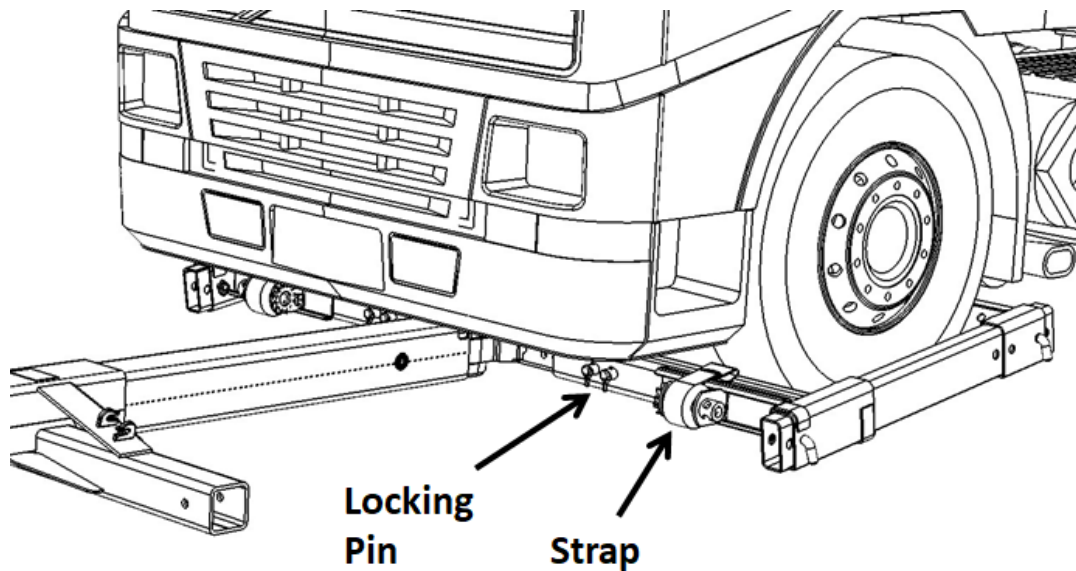

**FIGURE 65 – INSTALLING THE HEAVY DUTY TITRE LIFTS ON THE T-HEAD**

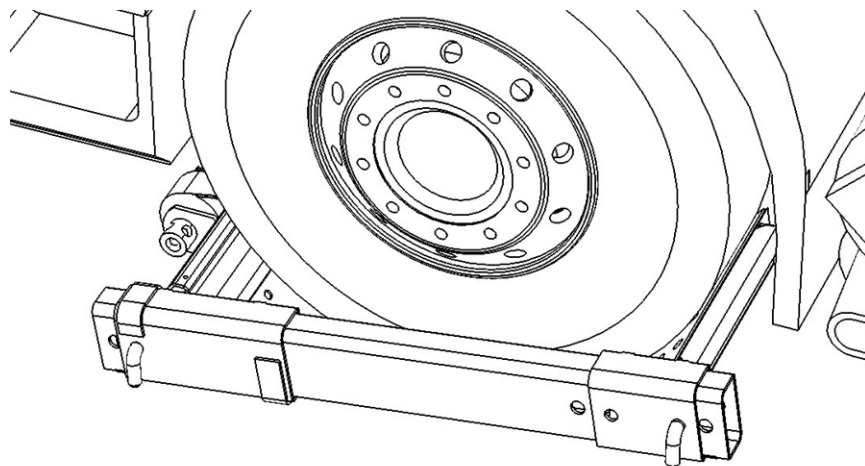

**FIGURE 66 – INSTALLING THE STRAPS**

## 9.5 Medium duty tire lifts

Medium duty tire lifts (commonly known as motor home brackets) are used to tow medium weight vehicles. They have a capacity of 2,267 kg (5,000 lb.) when used with the middle angle plates, or 2,720 kg (6,000 lb.) when not used with the middle angle plates. These tire lifts are installed on the T-head of the T-bar and secured in place with locking pins. They can be installed at different positions on the T-head to fit vehicles of different widths. The positions of the angled plates can also be adjusted to fit different wheel sizes.

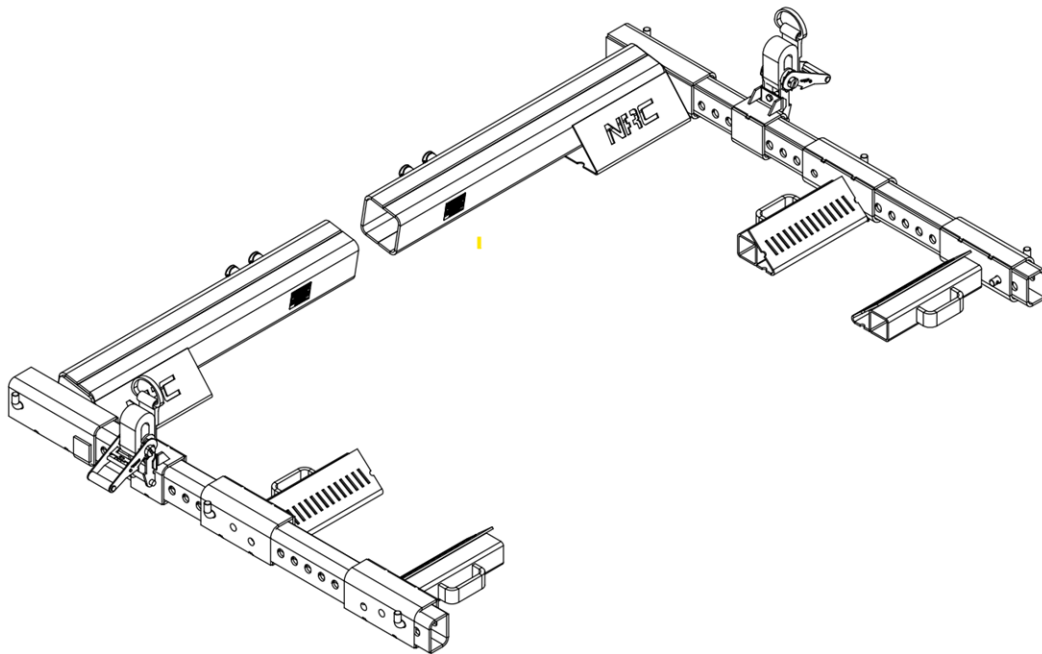

FIGURE 67 – EXAMPLE OF MEDIUM DUTY TIRE LIFTS

### 9.5.1 How to use the medium duty tire lifts

The medium duty tire lifts fit directly on the T-head of the T-bar and are secured in place with a locking pin.

1. Position the medium duty tire lifts on the T-head of the T-bar. Make sure to position the medium duty tire lifts appropriately for the dimensions of the vehicle to be towed.
2. Secure both medium duty tire lifts in place using the locking pins.

3. Position the angled plates to fit the wheel dimensions of the vehicle to be towed.
4. Secure each angled plate in place using the locking pin.

Once the medium duty tire lifts are installed, load the vehicle on the brackets and secure the vehicle in place.

1. Position the wheels of the vehicle on the angled plates.
2. Use straps to secure the vehicle in place. These go around the tire and attach to the back of the tire lifts.

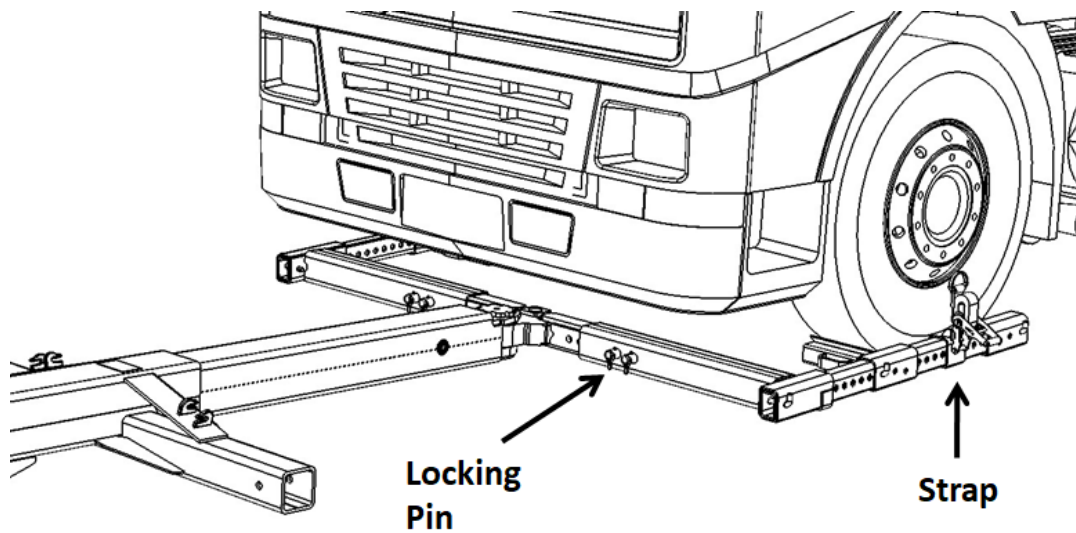

FIGURE 68 – INSTALLING THE MEDIUM DUTY TIRE LIFTS

## 9.6 Spreader bar

Spreader bars are used during vehicle recovery operations. Before beginning recovery, adjust the spreader bar length to fit the vehicle to be recovered. Using straps or chains, attach the wheels of the vehicle to the spreader bar. Once the vehicle is secure, you can proceed with recovery operations. Ensure that you do not exceed the capacities indicated on the spreader bar to ensure safe recovery and prevent dangerous situations.

Spreader bars have the following capacities.

**TABLE 32 – SPREADER BAR CAPACITIES - 3-SECTION SHORT (IN METRIC [IMPERIAL])**

	Element	Specification
30°	Retracted	6,000 kg [13,000 lb.]
	Extended	5,250 kg [11,600 lb.]
45°	Retracted	13,000 kg [28,400 lb.]
	Extended	9,000 kg [20,000 lb.]
60°	Retracted	27,000 kg [60,000 lb.]
	Extended	16,000 kg [35,200 lb.]

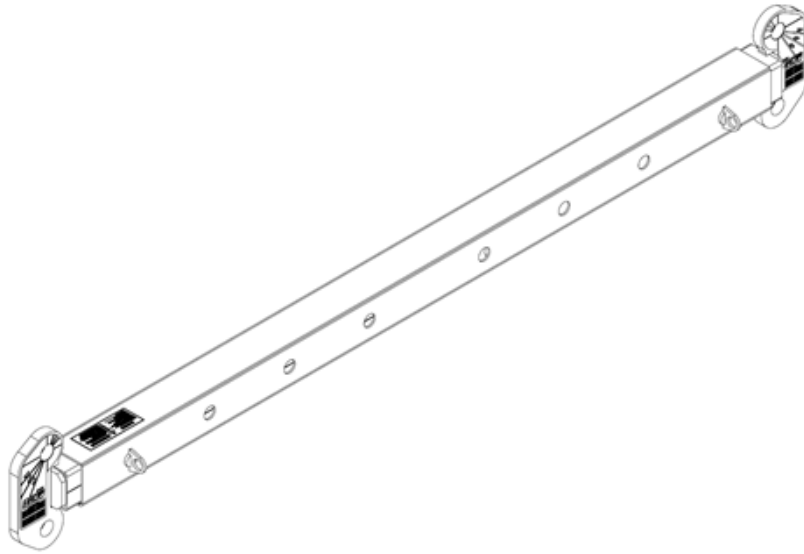

**FIGURE 69 – EXAMPLE OF A SPREADER BAR**

## 9.7 Snatch block

Snatch blocks are accessories used during vehicle recovery operations. They allow different setups to facilitate recovery. Ensure that you do not exceed the capacities indicated on the snatch block to ensure safe recovery and prevent dangerous situations.



FIGURE 70 – EXAMPLE OF A SNATCH BLOCK

## 9.8 Drawbar adapter

The drawbar adapter is used in Europe for towing. It is attached to the outside of the underlift rails at the rear of the tow truck.

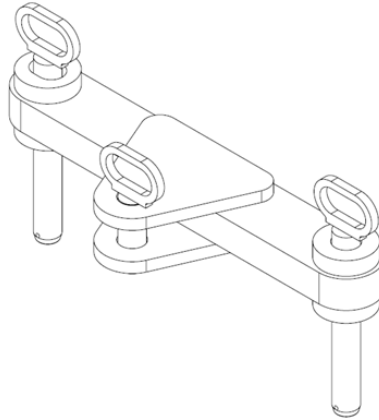
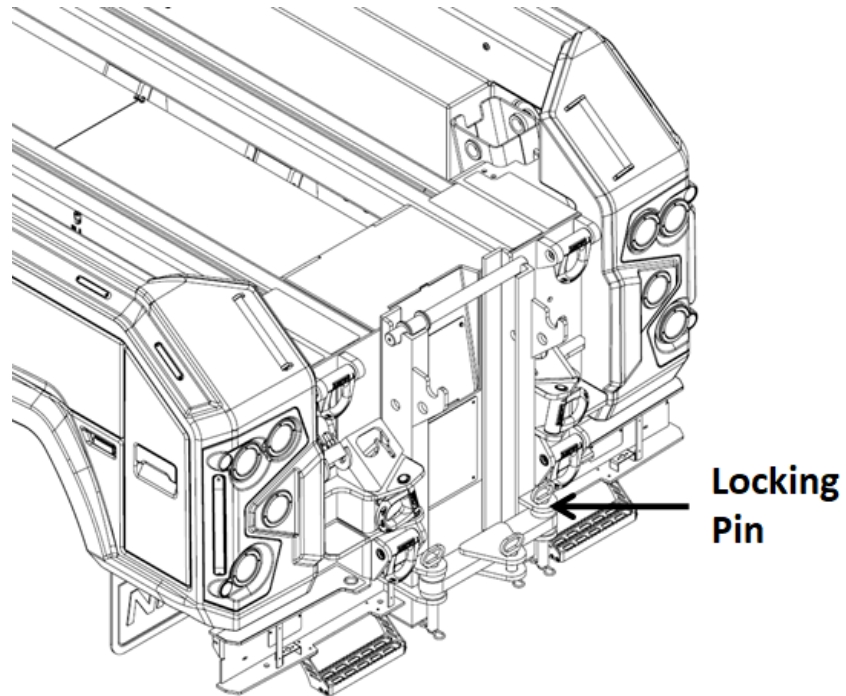

FIGURE 71 – EXAMPLE OF A DRAWBAR ADAPTER

### 9.8.1 How to use the drawbar adapter

The drawbar adapter is installed on the ladder plates at the rear of the tow truck. It is held in place with a locking pin.

1. Position the drawbar adapter on the ladder plates.
2. Secure it in place using the locking pin.



**FIGURE 72 – INSTALLING THE DRAWBAR ADAPTER**

## 9.9 Wood pads

Wood pads are accessories used with the outriggers. They distribute the load on the ground, which helps preserving the integrity of the ground. They must always be installed when using the outriggers.

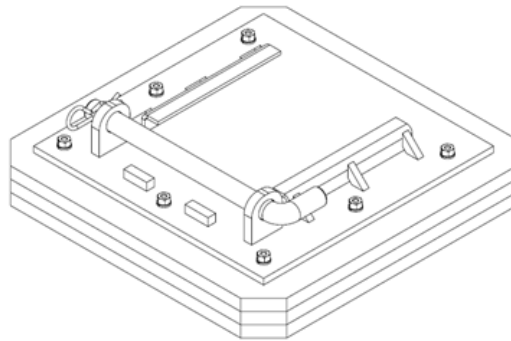

FIGURE 73 – EXAMPLE OF A WOOD PAD

### 9.9.1 How to use the wood pads

The wood pads are installed on the outriggers and are held in place with a locking pin.

1. Position one wood pad on each outrigger.
2. Secure each wood pad in place using the locking pin.

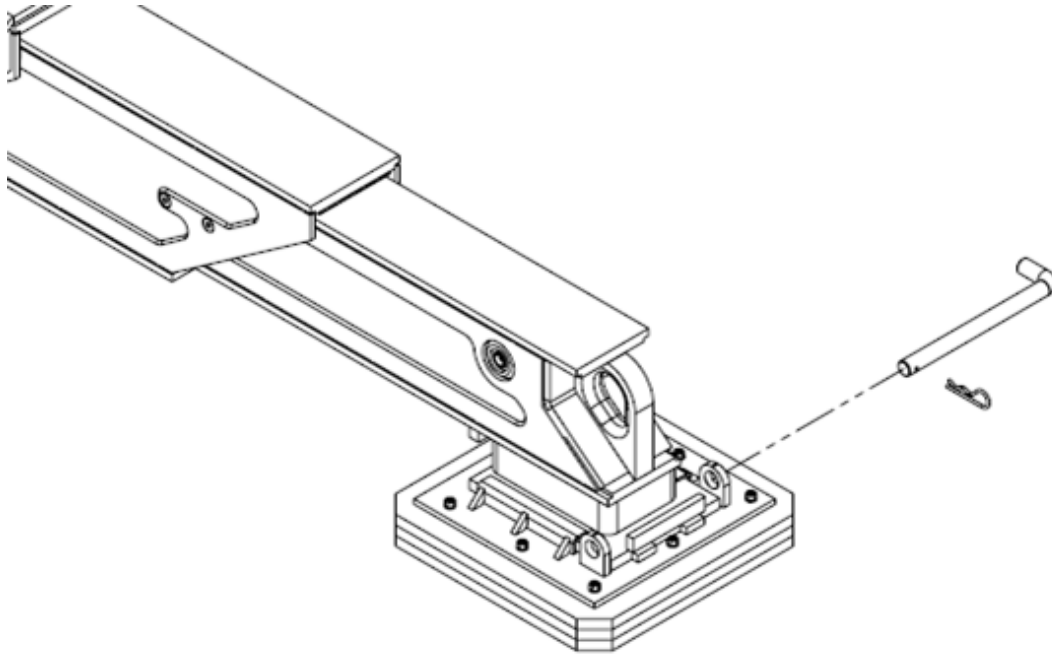

FIGURE 74 – INSTALLING THE WOOD PADS

## 9.10 Stabilizer grips

Stabilizer grips are accessories that are attached directly to an outrigger or wood pad. They provide more grip on the ground when wood pads are not sufficient. They are mainly used when drawing a load to provide better grip and prevent the tow truck from sliding.

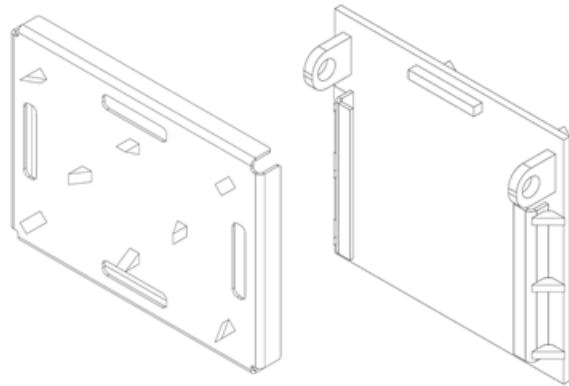
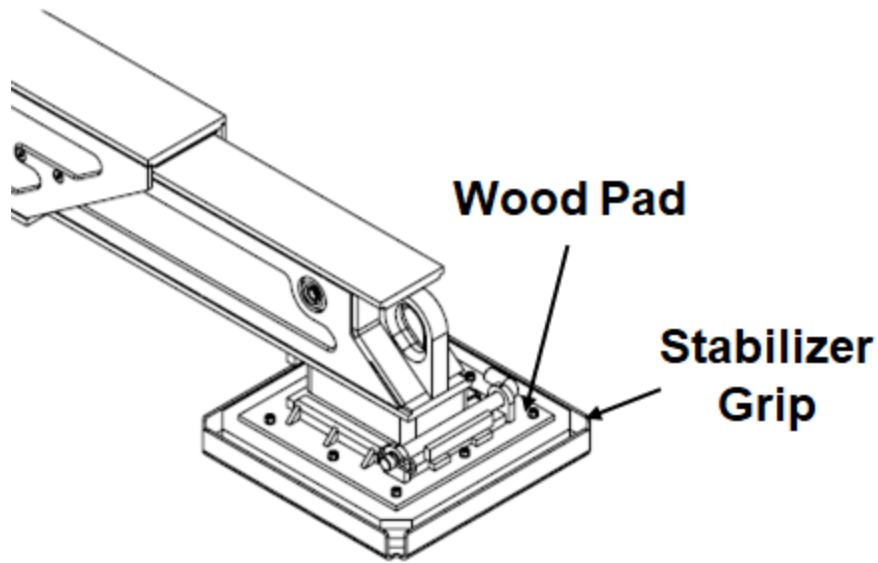

FIGURE 75 – EXAMPLES OF STABILIZER GRIPS

### 9.10.1 How to use stabilizer grips

The stabilizer grips that attach to the wood pads fit directly onto them. Contact with the ground keeps the stabilizer grips in place.

1. Position one stabilizer grip on the wood pad on each outrigger.
2. Lower the outrigger to make contact with the ground.



**FIGURE 76 – INSTALLING A STABILIZER GRIP ON A WOOD PAD**

The stabilizer grips that fit directly on the outriggers are held in place with a locking pin.

1. Position one stabilizer grip on each outrigger.
2. Secure each stabilizer grip in place using the locking pin.

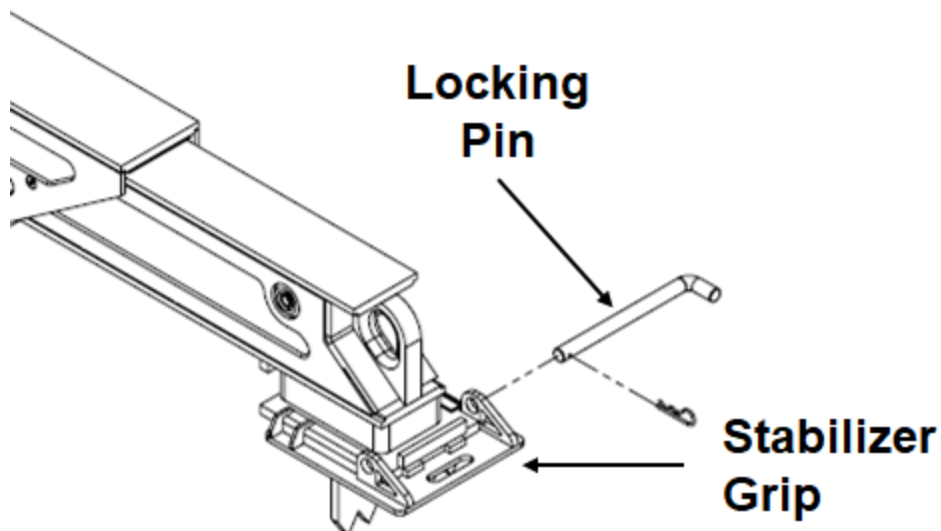

**FIGURE 77 – INSTALLING A STABILIZER GRIP ON AN OUTRIGGER**

## 9.11 Chains (tow chains and safety chains)

Tow chains and safety chains are used to secure the towed vehicle. Two safety chains and two tow chains must always be used before towing a vehicle. Safety chains are usually attached to the chain boxes on the tow truck, as well as on the towed vehicle. Tow chains are attached to the towed vehicle, as well as to the underlift or T-bar. The use of safety and tow chains may be governed by law. Make sure to always follow applicable regulations.

NRC also offers chains with a closed hook. They are used to perform different lifting operations.



## AUTHORIZED DISTRIBUTORS AND SERVICE PROVIDERS

Please visit our website for the list of authorized distributors and service providers, or scan the QR code below.

<https://nrc-industries.com/nrc-dealer/>





# LOGBOOK

Your logbook, which must be kept with your equipment, should contain the following information.

Logbook						
Date	Routine	Maintenance/ Frequency (Flushing, Greasing, Tightening...)	Other Tasks (Inspections, Disassembly, Repairs...)	Name and Title	Number of Hours of Operation	Observations (Part Numbers...)



## OPERATOR RECORD

Operator Name	Date



[NRC-INDUSTRIES.COM](http://NRC-INDUSTRIES.COM)

---

2430 Principale, St-Paul-d'Abbotsford, QC, J0E 1A0

T.450 379.5796 F.450 379.5796