

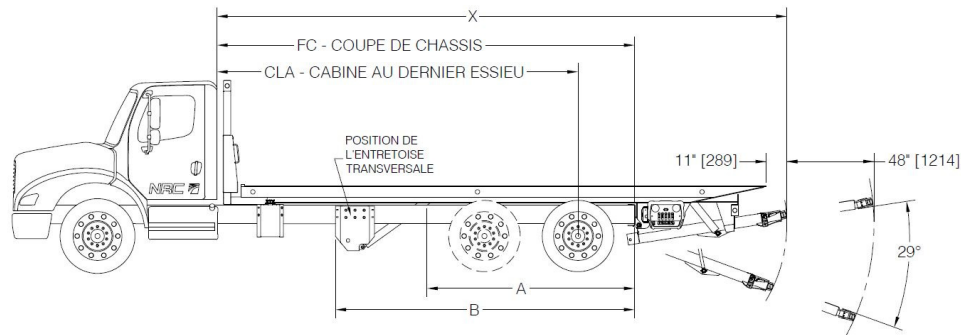

Modele: 20TB

Vos appels de services touchent tous les types de véhicules possibles et exigent de la polyvalence. Avec la série 20TB, vous pourrez affronter toutes les situations susceptibles de se présenter au quotidien et plus encore.



CLA RECOMMANDÉS POUR 20TB – SIMPLE & TANDEM

Longueur plancher Pi [mm]	A Po [mm]	B Po [mm]	SIMPLE		TANDEM		X Po [mm]
			CLA Po [mm]	FC Po [mm]	CLA Po [mm]	FC Po [mm]	
20 [6096]	73 [1854]	124 [3150]	144 [3658]	181 [4598]	N.A.	N.A.	265 [6731]
20 ½ [6248]	73 [1854]	124 [3150]	150 [3810]	187 [4750]	N.A.	N.A.	271 [6885]
21 [6401]	73 [1854]	124 [3150]	153 [3886]	193 [4903]	N.A.	N.A.	277 [7036]
21 ½ [6553]	73 [1854]	124 [3150]	159 [4039]	199 [5055]	N.A.	N.A.	283 [7189]
22 [6706]	73 [1854]	124 [3150]	162 [4115]	205 [5207]	N.A.	N.A.	289 [7341]
22 ½ [6858]	73 [1854]	124 [3150]	168 [4267]	209 [5360]	N.A.	N.A.	295 [7492]
23 [7010]	73 [1854]	124 [3150]	171 [4343]	217 [5512]	N.A.	N.A.	301 [7646]
23 ½ [7163]	73 [1854]	124 [3150]	177 [4496]	223 [5665]	N.A.	N.A.	307 [7798]
24 [7315]	113 [2870]	164 [4166]	184 [4674]	233 [5919]	196 [4978]	233 [5919]	317 [8052]
24 ½ [7468]	113 [2870]	164 [4166]	190 [4826]	239 [6071]	202 [5131]	239 [6071]	323 [8205]
25 [7620]	113 [2870]	164 [4166]	193 [4902]	245 [6223]	208 [5283]	245 [6223]	329 [8357]
25 ½ [7772]	113 [2870]	164 [4166]	199 [5055]	251 [6376]	214 [5436]	251 [6376]	335 [8509]
26 [7925]	113 [2870]	164 [4166]	202 [5131]	257 [6528]	220 [5588]	257 [6528]	341 [8762]
26 ½ [8077]	113 [2870]	164 [4166]	208 [5283]	261 [6681]	226 [5740]	261 [6681]	347 [8814]
27 [8230]	113 [2870]	164 [4166]	211 [5359]	269 [6833]	232 [5893]	269 [6833]	353 [8967]
27 ½ [8382]	113 [2870]	164 [4166]	217 [5512]	275 [6985]	238 [6045]	275 [6985]	359 [9119]
28 [8534]	113 [2870]	164 [4166]	220 [5588]	281 [7138]	244 [6198]	281 [7138]	365 [9271]
28 ½ [8687]	113 [2870]	164 [4166]	226 [5740]	287 [7290]	250 [6350]	287 [7290]	371 [9424]
29 [8839]	113 [2870]	164 [4166]	229 [5817]	293 [7443]	256 [6502]	293 [7443]	377 [9576]
29 ½ [8992]	113 [2870]	164 [4166]	235 [5969]	299 [7595]	262 [6655]	299 [7595]	383 [9729]
30 [9144]	113 [2870]	164 [4166]	238 [6045]	305 [7747]	268 [6807]	305 [7747]	389 [9881]
30 ½ [9296]	113 [2870]	164 [4166]	244 [6198]	311 [7900]	274 [6960]	311 [7900]	395 [1033]

*Le CLA peut varier de +/-3" sans changement nécessaire.

**Le CLA est mesuré à partir de la cabine ou de tous autres items dépassant. (Système d'échappement, réservoir, etc.)

*** Si l'option de coffre avec porte roll up est sélectionnée sur le support de lumières, ajouter 4 pouces à toutes les coupes de châssis dans ce document.



Modele: 20TB

Vos appels de services touchent tous les types de véhicules possibles et exigent de la polyvalence. Avec la série 20TB, vous pourrez affronter toutes les situations susceptibles de se présenter au quotidien et plus encore.

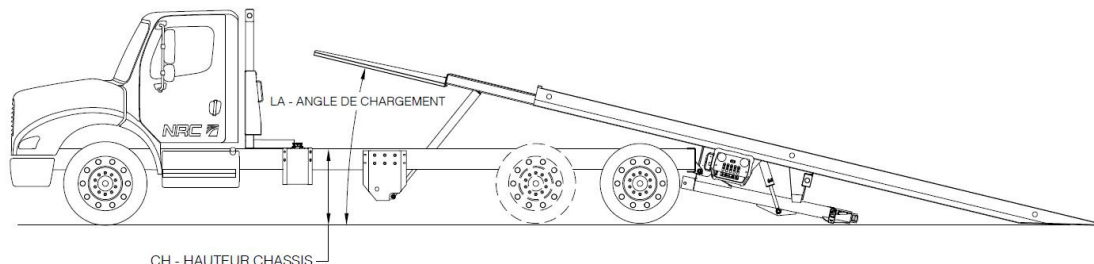

ANGLE DE CHARGEMENT ET HAUTEUR DE CHÂSSIS POUR 20TB						
CH Po [mm]	LA				CH+Y Po [mm]	
	20-23' / Profil bas	24-30' / Profil bas	20-23' / STD	24-30' / STD	Profil bas	STD
28 [711]	10.7°	10.9°	11.0°	11.2°	37.5 [953]	38.5 [978]
29 [737]	11.0°	11.2°	11.3°	11.5°	38.5 [978]	39.5 [1003]
30 [762]	11.3°	11.5°	11.5°	11.8°	39.5 [1003]	40.5 [1029]
31 [787]	11.6°	11.8°	11.8°	12.1°	40.5 [1029]	41.5 [1054]
32 [813]	11.8°	12.0°	12.1°	12.4°	41.5 [1054]	42.5 [1080]
33 [838]	12.1°	12.3°	12.4°	12.7°	42.5 [1080]	43.5 [1105]
34 [864]	12.4°	12.7°	12.7°	13.0°	43.5 [1105]	44.5 [1130]
35 [889]	12.7°	13.0°	13.0°	13.2°	44.5 [1130]	45.5 [1156]
36 [914]	13.0°	13.3°	13.3°	13.5°	45.5 [1156]	46.5 [1181]
37 [940]	13.3°	13.5°	13.6°	13.8°	46.5 [1181]	47.5 [1207]
38 [965]	13.6°	13.8°	13.8°	14.1°	47.5 [1207]	48.5 [1232]
39 [991]	13.9°	14.1°	14.1°	14.4°	48.5 [1232]	49.5 [1257]
40 [1016]	14.1°	14.4°	14.4°	14.7°	49.5 [1257]	50.5 [1283]
41 [1041]	14.4°	14.7°	14.7°	15.0°	50.5 [1283]	51.5 [1308]
42 [1067]	14.7°	15.0°	15.0°	15.3°	51.5 [1308]	52.5 [1334]
43 [1092]	15.0°	15.3°	15.3°	15.6°	52.5 [1334]	53.5 [1359]
44 [1118]	15.3°	15.6°	15.6°	15.9°	53.5 [1359]	54.5 [1384]

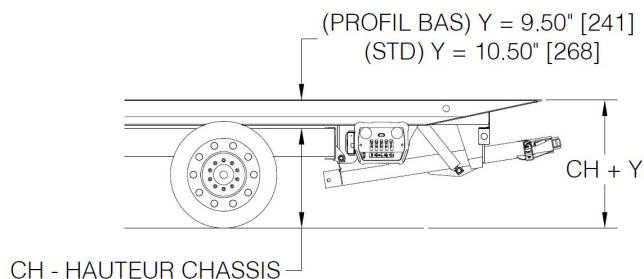

Modele: 20TB

Vos appels de services touchent tous les types de véhicules possibles et exigent de la polyvalence. Avec la série 20TB, vous pourrez affronter toutes les situations susceptibles de se présenter au quotidien et plus encore.

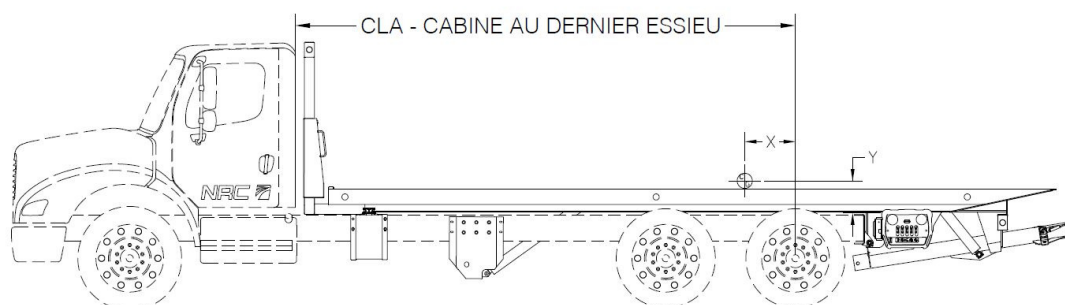

POIDS ET CENTRE DE GRAVITÉ ESTIMÉS POUR 20TB PROFIL BAS***							
Longueur plancher Pi [mm]	CLA Po [mm]		Centre de gravité - Po [mm]				Poids total estimé lb [kg]
	SIMPLE	TANDEM	Cg (x)*		Cg (y)**		
			SIMPLE	TANDEM	SIMPLE	TANDEM	
20 [6096]	144 [3658]	N.A.	14.75 [375]	N.A.	3.75 [92]	N.A.	7800 [3546]
20 ½ [6248]	150 [3810]	N.A.	16.50 [419]	N.A.	3.75 [92]	N.A.	7900 [3591]
21 [6401]	153 [3886]	N.A.	15.75 [400]	N.A.	4.00 [102]	N.A.	8000 [3636]
21 ½ [6553]	159 [4039]	N.A.	18.00 [457]	N.A.	4.00 [102]	N.A.	8100 [3682]
22 [6706]	162 [4115]	N.A.	17.00 [432]	N.A.	3.75 [92]	N.A.	8200 [3727]
22 ½ [6858]	168 [4267]	N.A.	19.50 [495]	N.A.	4.00 [102]	N.A.	8300 [3773]
23 [7010]	171 [4343]	N.A.	19.00 [483]	N.A.	4.00 [102]	N.A.	8400 [3818]
23 ½ [7163]	177 [4496]	N.A.	20.75 [527]	N.A.	4.00 [102]	N.A.	8500 [3864]
24 [7315]	184 [4674]	196 [4978]	25.25 [641]	37.25 [946]	4.75 [121]	4.75 [121]	8700 [3955]
24 ½ [7468]	190 [4826]	202 [5131]	27.00 [684]	39.00 [991]	4.75 [121]	4.75 [121]	8800 [4000]
25 [7620]	193 [4902]	208 [5283]	26.50 [673]	41.50 [1054]	4.75 [121]	4.75 [121]	8900 [4045]
25 ½ [7772]	199 [5055]	214 [5436]	28.75 [730]	43.75 [1111]	4.75 [121]	4.75 [121]	9000 [4091]
26 [7925]	202 [5131]	220 [5588]	27.75 [705]	45.75 [1162]	5.00 [127]	5.00 [127]	9100 [4136]
26 ½ [8077]	208 [5283]	226 [5740]	30.50 [775]	48.50 [1232]	5.00 [127]	5.00 [127]	9200 [4182]
27 [8230]	211 [5359]	232 [5893]	30.00 [762]	51.00 [1295]	4.75 [121]	4.75 [121]	9300 [4227]
27 ½ [8382]	217 [5512]	238 [6045]	32.50 [826]	53.50 [1359]	5.00 [127]	5.00 [127]	9400 [4273]
28 [8534]	220 [5588]	244 [6198]	31.50 [800]	55.50 [1410]	5.00 [127]	5.00 [127]	9500 [4318]
28 ½ [8687]	226 [5740]	250 [6350]	34.00 [864]	58.00 [1473]	5.00 [127]	5.00 [127]	9600 [4364]
29 [8839]	229 [5817]	256 [6502]	33.00 [838]	60.00 [1524]	5.00 [127]	5.00 [127]	9700 [4409]
29 ½ [8992]	235 [5969]	262 [6655]	35.75 [908]	62.75 [1594]	5.00 [127]	5.00 [127]	9800 [4455]
30 [9144]	238 [6045]	268 [6807]	35.25 [895]	65.25 [1657]	5.00 [127]	5.00 [127]	9900 [4500]
30 ½ [9296]	244 [6198]	274 [6960]	37.25 [946]	67.25 [1708]	5.00 [127]	5.00 [127]	10000 [4545]

*Le centre de gravité (x) est calculé à partir du centre du dernier essieu arrière.

**Le centre de gravité (y) est calculé à partir du dessus du châssis.

***Le poids et centre de gravité estimés sont seulement pour l'équipement. (Sans camion)

Modele: 20TB

Vos appels de services touchent tous les types de véhicules possibles et exigent de la polyvalence. Avec la série 20TB, vous pourrez affronter toutes les situations susceptibles de se présenter au quotidien et plus encore.

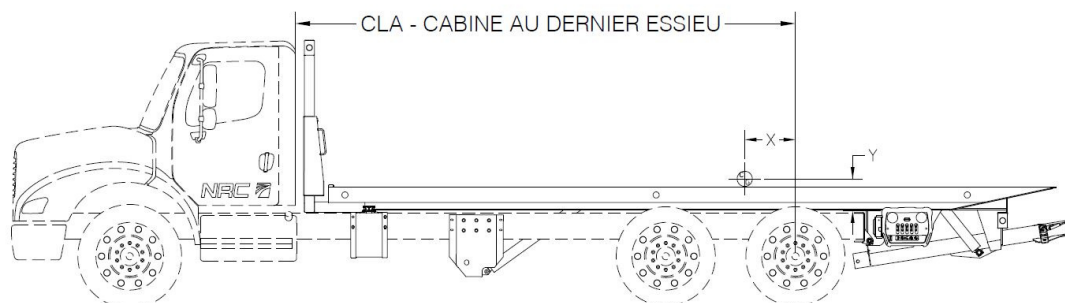

POIDS ET CENTRE DE GRAVITÉ ESTIMÉS POUR 20TB STD***							
Longueur plancher Pi [mm]	CLA Po [mm]		Centre de gravité - Po [mm]				Poids total estimé lb [kg]
	SIMPLE	TANDEM	Cg (x)*		Cg (y)**		
			SIMPLE	TANDEM	SIMPLE	TANDEM	
20 [6096]	144 [3658]	N.A.	14,75 [375]	N.A.	4,00 [102]	N.A.	7650 [3477]
20 ½ [6248]	150 [3810]	N.A.	17,00 [432]	N.A.	4,00 [102]	N.A.	7750 [3523]
21 [6401]	153 [3886]	N.A.	16,00 [406]	N.A.	4,00 [102]	N.A.	7850 [3568]
21 ½ [6553]	159 [4039]	N.A.	18,25 [464]	N.A.	4,00 [102]	N.A.	7950 [3614]
22 [6706]	162 [4115]	N.A.	17,50 [445]	N.A.	4,25 [108]	N.A.	8050 [3659]
22 ½ [6858]	168 [4267]	N.A.	19,50 [495]	N.A.	4,25 [108]	N.A.	8150 [3705]
23 [7010]	171 [4343]	N.A.	18,75 [476]	N.A.	4,25 [108]	N.A.	8250 [3750]
23 ½ [7163]	177 [4496]	N.A.	21,25 [540]	N.A.	4,25 [108]	N.A.	8350 [3795]
24 [7315]	184 [4674]	196 [4978]	25,75 [654]	37,75 [959]	4,75 [121]	4,75 [121]	8550 [3886]
24 ½ [7468]	190 [4826]	202 [5131]	27,50 [699]	39,50 [1003]	4,75 [121]	4,75 [121]	8650 [3932]
25 [7620]	193 [4902]	208 [5283]	27,00 [686]	42,00 [1067]	4,75 [121]	4,75 [121]	8750 [3977]
25 ½ [7772]	199 [5055]	214 [5436]	28,75 [730]	43,75 [1111]	4,75 [121]	4,75 [121]	8850 [4023]
26 [7925]	202 [5131]	220 [5588]	28,25 [718]	46,25 [1175]	4,75 [121]	4,75 [121]	8950 [4068]
26 ½ [8077]	208 [5283]	226 [5740]	30,75 [781]	48,75 [1238]	5,00 [127]	5,00 [127]	9050 [4114]
27 [8230]	211 [5359]	232 [5893]	29,50 [749]	50,50 [1283]	5,00 [127]	5,00 [127]	9150 [4159]
27 ½ [8382]	217 [5512]	238 [6045]	32,00 [813]	53,00 [1346]	5,00 [127]	5,00 [127]	9250 [4205]
28 [8534]	220 [5588]	244 [6198]	31,50 [800]	55,50 [1410]	5,00 [127]	5,00 [127]	9350 [4250]
28 ½ [8687]	226 [5740]	250 [6350]	33,50 [851]	57,50 [1461]	5,00 [127]	5,00 [127]	9450 [4296]
29 [8839]	229 [5817]	256 [6502]	33,00 [838]	60,00 [1524]	5,00 [127]	5,00 [127]	9550 [4341]
29 ½ [8992]	235 [5969]	262 [6655]	35,50 [902]	62,50 [1588]	5,00 [127]	5,00 [127]	9650 [4386]
30 [9144]	238 [6045]	268 [6807]	34,50 [876]	64,50 [1638]	5,00 [127]	5,00 [127]	9750 [4432]
30 ½ [9296]	244 [6198]	274 [6960]	37,00 [940]	67,00 [1702]	5,25 [133]	5,25 [133]	9850 [4477]

*Le centre de gravité (x) est calculé à partir du centre du dernier essieu arrière.

**Le centre de gravité (y) est calculé à partir du dessus du châssis.

***Le poids et centre de gravité estimés sont seulement pour l'équipement. (Sans camion)



Modele: 20TB

Vos appels de services touchent tous les types de véhicules possibles et exigent de la polyvalence. Avec la série 20TB, vous pourrez affronter toutes les situations susceptibles de se présenter au quotidien et plus encore.

Accessoires	Poids estimé lb [kg]
Lève roues avec T-bar	195 [89]
Panier 44"	250 [114]
Panier 72"	340 [154]
Coffre outil 44"	275 [125]
Coffre outil 72"	360 [163]