

# TECHNICAL DRAWING



**Title:** 10,000TB CARRIER DIMENSIONS SPECIFICATION

**Equipment:** 10,000TB CARRIER MODEL "C"

**Released:** November 17, 2009

**Revised:** February 06, 2013

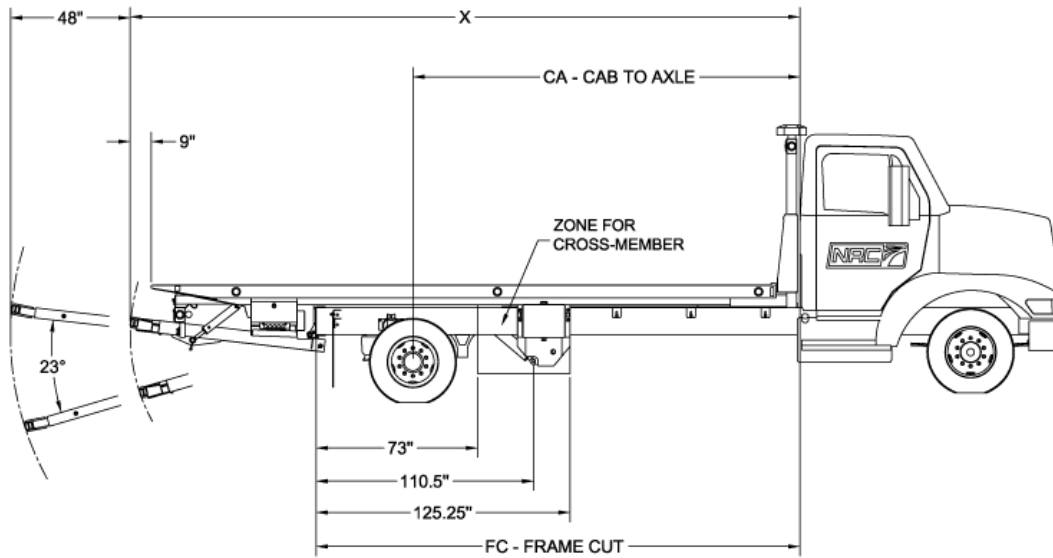

## RECOMMENDED CA FOR CARRIER

Single axle chassis Deck length (in ft)	Model "C"		Total length X
	CA	Frame cut	
18	120	155	234
18 1/2	126	161	240
19	132	167	246
19 1/2	138	173	252
20	144	179	258
20 1/2	150	185	264
21	153	191	270
21 1/2	159	197	276

**NRC Industries**

2430 Principale Est, St-Paul d' Abbotsford, Québec, Canada, J0E 1A0

Phone : +1 450 379 5796

Fax : +1 450 379 5995

**Technical Drawing**

7990001\_REV2

Copyright © 2009

Page 1 of 1